

Informal Pre-Conference Proceedings

Programme Committee

Tommy Dreyfus

Alejandro S. González-Martín

John Monaghan

Elena Nardi

Pat Thompson

<https://matriccalconf2.sciencesconf.org/>



STEM as Culture: Exploring exclusion and inclusion in mathematics and biology

Carrie Diaz Eaton

¹Bates College, United States of America; cdeaton@bates.edu

Abstract.

Finding a path for calculus in the biological sciences is not just about asserting an inherent place, but by enhancing and communicating the value of calculus. Thus, the key to a successful calculus is by reflecting on the culture of mathematics, the culture of biology, and the cultural space we create at the interface. Disciplinary culture is shaped by and shapes the disciplinary content we value, the language we use, and the way we treat each other. I draw on traditions of testimonio to share experiences, both personal and professional, in which the skills of boundary spanning between cultures were developed, critically refined, and empirically tested in the context of developing curriculum for calculus for life and environmental science.

Code switching and boundary spanning

Like all people, we perceive the version of reality that our culture communicates. Like others having or living in more than one culture, we get multiple, often opposing messages. The coming together of two self-consistent but habitually incomparable frames of reference causes un choque, a cultural collision. (Anzaldúa, 1987, p. 78)

It was less than a decade ago that I was first introduced to the work of Chicana scholar Dr. Gloria Anzaldúa. I was writing a duoethnography with my cousin on our journey as mathematics educators in the United States and the ancestral legacy of mathematics education we shared in Peru. It was more recently that I was introduced to Dr. Anzaldúa's work translingualing as she wrote about negotiating cultural borders from Mexico to the United States in *La Frontera* (Anzaldúa, 1987).

Like Dr. Anzaldúa, I grew up in two worlds - a father from South America and a mother from the United States whose ancestors arrived in the 1800s from Sweden, England, and Germany. My dad was Catholic and my mom was Protestant. My father's first language was Spanish, and my mom's first language was English. She nearly failed Spanish class in high school. As I was growing up, I did not realize that I was in *Nepantla*, learning how to bridge the gap between the

cultures of my parents. I consciously spent more energy navigating the gap between my parents' culture and the evolution of society. But in reality I have always been at Anzalda's La Frontera - a world away from the physical border, but at the cultural borders within our family.

At an early age, I understood that how I acted in church with my mom was very different than how I acted in church with my dad. Church services with my mom were about church hymnals and choir and gatherings were fun and loud, but focused around plays and craft fairs. Church services with my dad were in Spanish with a touch of Latin, ritualized praying and minimal singing. Church gatherings were all night parties due to quinceañeras with dancing and never-ending food. My mom's culture, the culture of British colonization, dominated my experience in the world. My dad's culture - *mezcla* of Indigenous and Spanish colonization imported from Latin America - was limited to a minoritized and underserved neighborhood of Providence, Rhode Island.

Later as I learned, researched, and taught at the interface of mathematics and biology through college and my career, I would unconsciously analyze and make decisions around the cultural norms of each discipline. It was natural for me to intentionally plan about how to fit in, how to dress and how to act, which jokes I could tell for mathematics audiences and which for biology, and how to anticipate power dynamics which might shape interactions. It was natural for me, because I had been expected to assimilate all my life, code-switching^[1] as necessary.

To establish credibility among mathematicians, I would plan to discuss a proof or show evidence of long equations behind the model simulations I presented. To establish credibility among biologists at conferences, I only had to state I was a mathematician. But to establish credibility as a biologist, to biologists, I had to understand the context of biological questions, understand the epistemology of the field, and reasonably justify any abstractions to my models with reference to prior experimental studies.

As a mathematics PhD student at the University of Tennessee with a concentration in mathematical ecology and evolutionary theory, I spent many years in a Ecology and Evolutionary Biology department journal seminars. The last year I was there, at the beginning of the semester, we performed re-introductions for the new graduate students and faculty. When I introduced myself as a mathematics major, the ecology and evolutionary biology students who I had known for years were shocked. They did not know my primary department affiliation was

^[1] Code-switching is a term used to describe switching between language and cultures. In marginalized communities it is often performed due to assimilation pressures as a matter of survival in hegemony (McCluney et al., 2019).

mathematics. At the time this was a great honor - a sort of proof of my mastery of code-switching.

To be able to successfully code-switch is to temporarily assimilate into a context and hide the presence of other identities. Since then, I have come to instead embrace *Nepantla*, an Indigenous idea introduced to mathematics education by Rochelle Gutiérrez (Gutiérrez, 2017). By being in the “in-between,” one experiences a new space of possibility. While code switching was a matter of survival and a drain on energy, the experience of code switching in my upbringing gave me an understanding of culture that would later impact how I engaged in interdisciplinary STEM education.

To me collaboration between disciplines is more than just working on the same grant or paper. To me, collaboration in mathematics education and biology education has been about people working together. People with their own cultural histories, norms, and languages. People who have to learn how to value each other’s contributions to STEM and STEM education and then find ways to collaborate around this shared vision (Eaton et al., 2023). Dr. Joe Redish writes about this extensively in his work between introductory physics and biology (Redish, 2012). Throughout this paper, I use a form of critical autoethnography, a *testimonio*, to share experiences and *conocimiento* which have shaped my approach to humanizing interdisciplinary STEM education and research (Quicke, 2010; Rodriguez-Campo, 2021).

Value and Language

As an assistant professor, I taught mathematics at Unity College - a small, undergraduate, private liberal arts college which trained environmental professionals. At the time I arrived, the college was undergoing a self-study due to a regional accreditation review. Some biology majors were considering eliminating Calculus I from the list of required courses (Eaton & Highlander, 2017). The reasoning: students were not choosing their program or major because they would have to take calculus, and either did not want to take mathematics other than statistics or did not have the prerequisites. Upon deeper probing, both biology students and biology faculty felt calculus was irrelevant to biology. This is not an uncommon conversation among biology and other majors which require calculus. There is plenty of research to illustrate how calculus has become an overzealous STEM gatekeeper (Ellis et al., 2016). Many biology departments have eliminated calculus as a requirement or have hired their own calculus instructor for a customized experience - like many biostatistics courses already.

Because of student interest, I had already been including more relevant biology applications in the calculus course. But now I had a new audience to please - major program directors. I set out

to create a calculus experience that also would deliver what program directors valued. First, I created a list of calculus topics and surveyed faculty across the programs to understand which topics were most important for their majors.

The results of my survey were disappointing. Very few topics were considered important. This was likely a fundamental contributor to the ongoing conversation to eliminate calculus as a requirement. But from a content analysis perspective, this made little sense. Prior conversations with all of these individuals indicated that population assessment and management relied on underlying theoretical dynamical systems models, modeling is a fundamental contributor to understanding climate change in the geoscience courses, and economics models are used in conversations about sustainability and resource management. I decided to follow up with one on one interviews with some of these program directors to ask why topics like “derivatives” were not listed as important.

I discerned a key difference in those conversations: understanding “derivatives” were not viewed as important, but understanding and describing “rates of change” was considered important. To mathematicians, these terms describe the same concepts. To our colleagues, scientists, and students, in life and environmental science, these terms are fundamentally different.

“Derivatives” are perceived as a set of abstracted formulas and rules. “Rates of change” describes how these abstracted concepts are useful in their fields. Likewise, “first order differential equations” rated extremely low, but “feedback loops” rated extremely high. Redish and Kou describe these as differences in the “‘dialect’ of speaking math” (2015, p. 563). I incorrectly assumed my audience already had fluency in translating my dialect of math to their disciplines and could easily recognize the value of abstracted mathematics. They valued calculus, but more specifically, their dialect of calculus (Eaton & Highlander, 2017). See works of Diaz Eaton and Callender Highlander for the final version of the survey.

As a direct result of my new survey findings, instead of dismissing exponential functions as precalculus material, I contextualized exponential functions from a modeling perspective in Calculus I. We introduced geometric sequences and equilibrium first. Then later, after introducing the idea of infinitesimal difference, change, and derivatives, re-introduced the continuous analog - exponential equations. Together, we solved the mystery of why exponential functions matter; They are an alternate form of the simplest autonomous differential equation describing a situation in which the instantaneous rate of change is proportional to the current size or magnitude. This key idea is what sets the exponential curve apart from all other functions with positive first and second derivatives. It also explains why exponential functions are heavily used

in population dynamics - because populations like bacteria continuously reproduce in proportion to their current number.

I collaborated with Dr. Callendar Highlander who also taught a newly revised biocalculus course at the University of Portland and Dr. Aikens, a qualitative researcher, to analyze student data from across both schools' new biocalculus students. One interesting surprise was that on pre- and post-course surveys, students did not report significant changes in their belief of mathematics' utility-value to biology. However, it was in the qualitative responses, where they were asked to describe how mathematics is used in biology that we saw the biggest and most significant changes. Students used more specific examples and showed a newly gained fluency in discussing mathematical terms in biology (Aikens, Highlander, & Eaton, 2021).

One year I had the opportunity to co-teach Spanish. Reading the literature on teaching foreign languages allowed me to reflect on mathematical translation as linguistic practice. It is not enough to teach vocabulary and grammatical rules. You must also understand how to put these together in a meaningful sentence in the context of a conversation which takes place within a particular culture. Over time, you can move from translating words to translating ideas - possibly the difference in relying on Google Translate versus a trained interpreter. We read Pablo Neruda, compared the Spanish and English versions, and discussed possible alternate translations to preserve the word choice, the ideas, and the art - both visual and auditory - of the poem. I use the example of *saber* and *conocer* to illustrate. These are two words that mean "to know" in Spanish. We use *saber* when we are typically talking about knowing a fact or learning a skill, and we use *conocer* when knowing a place or person. It is not enough to teach calculus as a collection of definitions and algebraic rules and ask "*¿Qué sabe?*". We must focus more broadly on translation, between representations and dialects, between disciplines and cultures and ask "*¿Cómo lo conoce?*". We already "know" this linguistically in Spanish-speaking cultures, as accumulated knowledge is referred to as "*conocimiento*" or wisdom.

Modeling and Microaggressions

In 2015, collaborators and I convened a working group on the teaching of modeling at the National Institute for Mathematical Biology and Synthesis. Our working group represented researchers from mathematics, biology, math biology education, physics education, science education, math education and professional development. By the end of our first in-person meeting, it was clear that we were circling around something fundamental - we each had different understandings of the words "model" and "modeling" based on our (sub)disciplinary epistemologies. Those in biology defined "modeling" in ways that implied that datasets were

involved in the process of creating a model. Those in mathematics defined “modeling” in ways that implied that a dataset was unnecessary in the creation of a model. Translation of language was not the issue - it was that concept the language conveyed that had a different meaning in each cultural context.

We coined the term “disciplinary microaggressions” - an act of exclusion that may or may not be intentional and occurs as a result of disciplinary cultural power dynamics and language - from our own *testimonios*. During the working group, I recounted how I was told that one of my research students was not eligible for the research award because their modeling project did not require them to collect their own data. My colleague recounted how her department criticized her bioinformatics research using data science because it did not follow a “scientific method” in which there was *a priori* development of a testable hypothesis. I also admitted how I have been the perpetrator of microaggressions myself. I was visiting an institution to give a talk and one biologist, who knew I was a mathematician, enthusiastically offered to show me their data. In response, I said “I do not work with data - I worked with theoretical models,” which effectively shut down the conversation. I did not intend to cut off the conversation - I had only classroom-based experience with data and no experience with data fitting in my own research yet. I did not consider myself a statistician and thought I was helpfully clarifying a distinction in fields. Building a theory of disciplinary microaggressions gave me a new mental model to make sense of my prior interactions and to reflect on my own behaviors to improve. I can more clearly see and reject many ways in which our STEM cultures enact exclusionary macro- and micro-aggressions within and between disciplines as a way to establish hierarchy.

These conversations resulted in a “Rule-of-five” paper which laid out definitions for model and modeling that were inclusive of all our perspectives (Eaton et al., 2019). Our definition of model allowed us to embrace multiple representations common across calculus, science education, and math education: algebraic, numeric, visual, verbal, and experiential. Our definition of modeling allowed the process of modeling and the process of science to start the process of abstraction and modeling at any of these representations embracing the multiple epistemologies present. This helped us see the commonalities across our work and perspectives so that we could achieve more together. This reflects a second Indigenous epistemology which Gutiérrez discusses, In Lak’ech (Gutiérrez, 2017). However, in the Rule-of-Five paper, we used the parable of the blind man and the elephant as an analogy. Each of us alone, with our own disciplinary perspectives, are discovering something about some context, and together they build broader stories.

The framework helped biology and science educators understand how mathematical modeling may generate data as a later step, but why data is not seen as a requirement to engage in

modeling. The mathematicians also came to appreciate how the field experience and the wet lab were important entry features of the biology modeling experience, which might be better leveraged by mathematics classrooms. Together our differing approaches and epistemologies were part of a broader picture of creating understanding. For example, mathematical models and field or lab-derived data are compared with each other and this is used to refine our mental models. Drawing on the rule-of-five framework to counteract disciplinary microaggressions also helped me personally reconceptualize my own relationship to data as a mathematician.

Our paper (Eaton et al., 2019) positioned the rule-of-five framework as a way to provide an inclusive scaffold of knowledge and skills for teaching modeling across life science and other disciplines. In the traditions of Yosso's cultural wealth (Yosso, 2005), we hoped to help instructors see and articulate the cultural assets students bring to calculus through their culture and knowledge of their life science disciplines. Instructors could also use the framework to reflect on engaging life students through the comfortable and familiar doors of data and experiential learning. For example, I now contextualized exponential functions in Calculus I by introducing a long-term dataset illustrating rising carbon dioxide levels over time. We could then introduce log-transformation of data and practice linear model fitting.

Intersectionality is a framework to discuss how race, gender and class identities introduce multiple, intersecting, and potentially multiplicative axes of oppression (Crenshaw, 1991). Applying an intersectionality framework to research in higher education has expanded this lens to additional social identities such as queerness and college identities such as status as a transfer student (Harris & Patton, 2018; Leyva & Joseph, 2023). Our use of "disciplinary microaggressions" named how (sub)disciplinary identity, values, and hierarchies might shape experiences in STEM classrooms, STEM departments, and STEM collaborations. With the broader framework of intersectionality added to my mental model, I have been re-examining the same *testimonios* shared above to consider how disciplinary identity interacts with other social identities. My bioinformatics colleague most certainly had experienced a subdisciplinary microaggression, but had also talked about how she was one of the only women on the tenure-track in her department. Withholding award eligibility for research I had mentored was certainly a disciplinary microaggression to assert the value of experimental science [over mathematical modeling]. But this act has to also be contextualized by the identity of the research mentor: the only faculty of color in the college, a new assistant professor, and a representation of a broader fundamental change in the value of mathematics in the field of biology.

A common phrase is that "children learn from the actions of their parents." My quest to implement a more inclusive paradigm in my teaching and with my students has been deeply

informed not just by working with students over many years, but also by my experiences with other colleagues in academia. I remember talking to a colleague who was a first-generation college student, and she said that you can learn a lot about a faculty member by the way they treat staff members at the college. Likewise, it is hard to imagine how to be inclusive in the classroom if you enact harm between faculty members, at professional conferences, or in the broader community. I work with intentionality to reach across the many borders drawn on our work across disciplinary and social identities and continue to find ways to include instead of exclude. I consciously make the assumption that all people have something to contribute to the intellectual conversation, not regardless of their background and identities, but specifically because of their backgrounds and identities. This is the underlying message of the Rule-of-Five paper, but D'Ignazio and Klein discuss this more thoroughly in their book *Data Feminism*:

Rather than viewing these positionalities as threats or as influences that might have biased our work, we embraced them as offering a set of valuable perspectives that could frame our work. This is an approach that we would like to see others embrace as well. Each person's intersecting subject positions are unique, and when applied to data science, they can generate creative and wholly new research questions. (D'Ignazio & Klein, 2020, p. 83).

Relationships and care

It is challenging sometimes to give advice to others about how to best collaborate across mathematics and biology, because I see myself as both a mathematician and a biologist. My training throughout my degrees has been interdisciplinary, though my degrees have been in mathematics. But in taking formal coursework from both departments, I was immersed in the culture of each discipline. I was also fortunate to have courses which drew from both disciplines simultaneously. But as I have moved into education research, computer science, data science, and social justice where I have less formal coursework, I have realized how important it is to read the literature of those disciplines, engage in conversations and collaboration with researchers in those disciplines, and understand their cultural values and norms. Nothing has helped me more in these endeavors than creating and sustaining personal and collaborative relationships beyond disciplinary walls.

It took three years of conversations and idea refinement to finish the rule-of-five paper. "Relationships", more than "collaborations" as a term, implies a deepness in the thought and sharing across positionalities, cultures, identities, and context. One of the reasons why I believe biocalculus reform at Unity was so successful was because Unity students had an extremely

strong disciplinary identity related to their major. Many students never switched their majors, and even if they did, the choices all lay within life science and environmental studies.

After working to design calculus for biology, environmental science, and wildlife, I turned my attention to marine biology, because of the relationships I developed with my collaborator while carpooling. She shared feelings of exclusion from the conversation about calculus for biology. I was guilty of this exclusion. I assumed that because I was using examples of modeling fish stock assessment, I was attentive to marine biology. But I learned that freshwater ponds are not salty marine environments, and I worked with her to contextualize the aforementioned carbon dioxide and climate change project against a need to address the health of coral reef ecosystems. It was only through developing relationships that I could see the ways in which I was erasing identity and expertise and find pathways together to new possibilities.

We have invested significant resources into researching “team science” so that STEM practitioners can work with each other across cultural boundaries (Hall et al., 2018). When I began implementing a full day to discuss teamwork organization and practices at the beginning of class-based team projects, my returns were ten-fold. Now, with the interest in open science, I see developing diverse open science [education] communities to share and improve science [education] just as important as developing the cyberinfrastructure to share open science [education]. But developing collaborative communities across cultural spaces is not just a transactional checklist of practices - it is grounded in relationship building.

STEM academic research culture does not always value investment in relationship building. Mathematics, in particular, has a historical perception of solitary genius - but here, I offer counter narratives. A conservation law enforcement professor stopped me once in the hallway, excited to tell me about a class activity using time-of-death tables for animal necropsies. I learned that they were used in poaching cases and now had a new tool to engage students in understanding Newton’s Law of Cooling. The wildlife biology professor with whom I shared many teaching discussions over lunch would reference my calculus class often as a source of learning population modeling concepts more deeply, which raised my course’s credibility and value to students. My teaching and my scholarship have greatly benefited from carpool rides, hallway conversations, and cafeteria lunches.

Fostering community is easier when there is clear value to all participants - a mutual benefit and a shared goal. This conceptualization is likely influenced by my PhD research on the evolution of mutualistic communities. Mutualistic communities, such as plants and pollinators, are diverse and resilient communities. I see a mutualism between the disciplines of mathematics and biology and a mutualism between humans in the disciplines of mathematics and biology. Therefore, the

fostering of inclusive and mutualistic communities is a critically important and necessary condition for a resilient and diverse STEM and STEM Education.

Coincidentally or not, reciprocity is the third and final Indigenous epistemological principle that Gutiérrez introduces in *Living Mathematics* (Gutiérrez, 2017). Together, *Nepantla*, reciprocity, and *In Lak'ech*, are the philosophies that have shaped my work netweaving (Goldstein et al., 2017). I foster communities of learners and leaders, first as the Consortium Director for QUBES (Donovan et al., 2015), with networks funded by the National Science Foundation's Research Coordination Networks for Undergraduate Biology Education (Eaton et al., 2017), and more recently with the RIOS institute (Eaton et al., 2022).

However, as much as my netweaving may seem to focus on postsecondary educators, students are a key part of our communities as well. My biocalculus redesign work was at its best when I involved students as collaborators, and I have had many students as curriculum advisors, research assistants, and co-authors. *In Lak'ech* is a reference to seeing yourself in the person you are greeting and when used as a classroom practice or a research practice with students, it demands that we break down the hierarchies that are part of academic epistemologies (Gutiérrez, 2017). Viewing students as colleagues with their own knowledge to share is a form of "open education" and creates pathways for students to participate in work that matters to themselves and to each other (Eaton et al., 2022). I pair that with attention to creating a community of care so that it is clear that we are all working towards the same goals together, supporting each other, and caring for each other's success (Clemens & Robinson, 2021).

When Aikens, Callender Highlander, and I (Aikens, Highlander, & Eaton, 2021) analyzed open-ended student responses in surveys about our newly revised biocalculus courses across two institutions, we focused on students whose attitudes towards mathematics improved. Students reported more positive attitudes due to realizing mathematics utility-value for life science, due to understanding the mathematics presented, and due to the instructor fostering a positive learning environment (Aikens, Highlander & Eaton, 2021). Creating and leveraging relationships that reach across disciplinary boundaries, helps us translate the dialect of mathematics. However, this development of "instructor-student rapport" and mutualistic relationship, where instructors care about the student and their success, is just as important in creating positive relationships with mathematics. Again, we see a nexus where valuing disciplinary cultures intersects with valuing the individual as a human, with relationships at the core of this work.

Humanizing and contextualizing

What we choose to discuss is just as important as what we choose not to discuss.

Dr. Callender Highlander and I had two separate methods for assessing student outcomes in our biocalculus courses in comparison to others'. Each returned a different, but important lesson. At the University of Portland, Dr. Callender Highlander compared three quizzes that the traditional calculus and the biocalculus course both administered (Eaton & Highlander, 2017). The first quiz was primarily a test of precalculus skills and the traditional calculus students outperformed the students in biocalculus. This finding suggests that biology students had fewer skills in the prerequisite precalculus course, but it could have also reinforced the stereotype that biology students were "worse at math." However, by the third quiz at the end of the course, the biocalculus students outperformed the traditional calculus students. This directly counternarrates the stereotype - biology students are indeed capable of high mathematics achievement, but needed a different kind of experience to realize that achievement.

I used the Calculus Concept Inventory (CCI) to understand learning at Unity College in the biocalculus course as it was revised (Eaton & Highlander, 2017). This allowed a comparison to outcomes at the University of Michigan which had extensive CCI gain data for its traditional calculus course and was considered a leader in calculus research (Koch & Herrin, 2006). The biocalculus course was doing admirably well, except for I noticed that in two semesters the CCI learning gains crashed. The most significant change: implementing gateway-style examinations like those at the University of Michigan. Students had to achieve a passing grade on each examination in order to pass the course. However, I could tell that my students were extremely stressed, so after these two semesters, I removed them. My students' CCI gains then bounced back.

It could be argued that gateway examinations exposed a fundamental difference in how biology students and engineering students best display learning in calculus. However, it may also be important to consider that incoming Michigan students boast a nearly perfect math SAT score and that many students at Unity struggled with disabilities and severe math anxiety. The context of our educational reform deeply matters when theory meets implementation. Kanim and Cid (Kanim & Cid, 2020) have a paper describing this issue in physics education, with particular attention to whether our research in the United States is appropriately capturing populations that are underrepresented in STEM.

Over the years, I have spent more time making sure curriculum and classroom experiences are crafted with universal design in mind, creating experiences that are accessible and inclusive for students with disabilities without additional accommodation. These students are invisible often

until accommodation notices are sent to instructors^[2], and then we only know to accommodate students who ask. In addition, many of the accommodations we make, such as extra test time, are visible to other students and may be perceived as “unfair” to such students (Deckoff-Jones & Duell, 2018). In many of the classes I teach now, I have replaced exams with projects. Extra time for due dates are easily accommodated as long as they show progress towards their goal. This kind of design illustrates to students that I see them, but they maintain control over who sees their disability or their mental health status. This care-based approach has become even more important in the midst of our mental health crisis in education during the pandemic (Lee et al., 2021).

There are also ways that I have intentionally made the invisibilized visible. I talk about key figures behind the science, who they are, and make sure that the readings and research I use in class represent the diversity of mathematicians and scientists I want to nurture. This includes unpacking the racist past of those that are behind the foundations of statistics as I discuss Pearson’s correlation coefficient (Quick, 2020). I share my identity as a queer Latina in the United States more because I am often read as part of the hegemony (Busch et al., 2022). The more than 60-year data set on carbon dioxide emissions I had adopted to contextualized exponential functions came from an observatory on Mauna Loa, a mountain in Hawai’i; This became an opportunity to make visible the long struggle that Native Hawaiians have fought for sovereignty, with more recent news regarding a proposal for a new observatory on the sacred mountain of Mauna Kea (Kahanamoku et al., 2020).

A colleague of mine asked what my classroom “intervention” was in order to propose an educational research experiment. What is it about STEM culture that this humanizing approach is considered an intervention? I do not mean that we have to reject our own culture completely, but rather recognize how our cultures are already shaping academia and STEM in ways that can exclude people and perspectives that are valuable to our future. Calculus can no longer afford to be a “gatekeeper” (Stinson, 2004). We need to visibilize, value, and center the intersectional disciplinary and social identities of our students and each other so that we can achieve interdisciplinary and inclusive STEM education experiences.

Acknowledgment

A key acknowledgement to all of the students who supported my work in biocalculus. A big thanks to so many colleagues for their conversations and collaborations which have shaped my

^[2] In the United States, the Americans with Disabilities Act (www.ada.gov) can be invoked by students to request accommodations which allow equal access to educational opportunities.

understanding of their disciplines. There are too many names to mention, but these relationships have been absolutely crucial and so important to me. This material is based upon work supported by the NSF under grant no. DBI-1919879, DUE-1625771, DUE-1446258, DBI-1543972, DBI-1346584, the William and Flora Hewlett Foundation, and Bates College and Unity College faculty grants and sabbatical funds. A key portion of this work was developed during the “Unpacking the Black Box: Teaching Quantitative Biology” Working Group at the National Institute for Mathematical and Biological Synthesis (NIMBioS), sponsored by the National Science Foundation through NSF award #DBI-1300426, with additional support from The University of Tennessee, Knoxville. Institutional review board authorizations for BioCalculus research #UnityIRB 2011-06 and #UPIRB 2011.

References

- Aikens, M.L., Eaton, C.D., & Highlander, H.C. (2021). The Case for Biocalculus: Improving Student Understanding of the Utility Value of Mathematics to Biology and Affect toward Mathematics. *CBE- Life Sciences Education*, 20(1). <https://doi.org/10.1187/cbe.20-06-0124>
- Anzaldúa, G. (1987). *Borderlands/La Frontera: The New Mestiza* (1st ed.). Spinsters/Aunt Lute.
- Busch, C.A., Supriya, K., Cooper, K.M., & Brownell, S.E. (2022). Unveiling Concealable Stigmatized Identities in Class: The Impact of an Instructor Revealing Her LGBTQ+ Identity to Students in a Large-Enrollment Biology Course, *CBE-Life Sciences Education*, 21(2). <https://doi.org/10.1187/cbe.21-06-0162>
- Clemens, C.M., & Robinson, T.M. (2021). Toward a New Community of Care: Best Practices for Educators and Administrators During the COVID-19 Pandemic, *Journal of Communication Pedagogy*, 5, 135-142. DOI: 10.31446/JCP.2021.2.14

Crenshaw, K. (1991). Mapping the Margins: Intersectionality, Identity Politics, and Violence against Women of Color, *Stanford Law Review*, 43(6), 1241–1299.

<https://doi.org/10.2307/1229039>

Deckoff-Jones, A., & Duell, M. N. (2018). Perceptions of appropriateness of accommodations for university students: Does disability type matter?. *Rehabilitation psychology*, 63(1), 68–76. <https://doi.org/10.1037/rep0000213>

D'Ignazio, C., & Klein, L.F. (2020). *Data Feminism*. MIT Press.

Donovan, S., Eaton, C.D., Gower, S.T., Jenkins, K.P., LaMar, M.D., Poli, D.B., Sheehy, R., & Wojdak, J.M. (2015). QUBES: a community focused on supporting teaching and learning in quantitative biology, *Letters in Biomathematics*, 2(1), 46-55.

<http://dx.doi.org/10.1080/23737867.2015.1049969>

Eaton, C.D., Allen, D., Anderson, L.J., Bowser, G., Pauley, M.A., Williams, K.S., & Uno, G.E. (2017). Summit of the Research Coordination Networks for Undergraduate Biology Education, *CBE-Life Sciences Education*, 15(4). <https://doi.org/10.1187/cbe.16-03-0147>

Eaton, C.D., Bonner, K., Cangialosi, K., Dewsbury, B., Diamond-Stanic, M., Douma, J., Smith, M., Taylor, R., Wojdak, R., & Wilfong K. (2022). Sustainability and Justice: Challenges and Opportunities for an Open STEM Education, *CBE-Life Sciences Education*, 21(3).

<https://doi.org/10.1187/cbe.20-08-0180>

Eaton, C.D., Highlander, H.C., Dahlquist, K.D., Ledder, G., LaMar, M.D., & Schugart, R.C. (2019). A “Rule-of-Five” Framework for Models and Modeling to Unify Mathematicians and Biologists and Improve Student Learning, *PRIMUS*, 29(8), 799-829. DOI:

[10.1080/10511970.2018.1489318](https://doi.org/10.1080/10511970.2018.1489318)

Eaton, C.D., Zhao, Y., & Taylor, R. (2023). Centering connections and collaborations in the evaluation of STEM education transformation, *Research on Undergraduate Mathematics Education (RUME) XXV Conference Proceedings*.

Ellis, J., Fosdick, B.K., & Rasmussen, C. (2016). Women 1.5 Times More Likely to Leave STEM Pipeline after Calculus Compared to Men: Lack of Mathematical Confidence a Potential Culprit. *PLoS ONE 11(7)*, Article e0157447.

<https://doi.org/10.1371/journal.pone.0157447>

Goldstein, B. E., Chase, C. S., Frankel-Goldwater, L., Osborne-Gowey, J., Risien, J., & Schweizer, S. (2017). Transformative Learning Networks: Guidelines and Insights for Netweavers. *Network of STEM Education Centers*.

Gutiérrez, R. (2017). Living Mathematx: Towards a Vision for the Future. *Philosophy of Mathematics Education Journal*, 32.

Hall, K. L., Vogel, A. L., Huang, G. C., Serrano, K. J., Rice, E. L., Tsakraklides, S. P., & Fiore, S. M. (2018). The science of team science: A review of the empirical evidence and research gaps on collaboration in science. *The American psychologist*, 73(4), 532–548.
<https://doi.org/10.1037/amp0000319>

Harris, J.C. & Patton, L.D. (2018). Un/Doing Intersectionality through Higher Education Research, *The Journal of Higher Education*, 90(3), 347-372. DOI:
[10.1080/00221546.2018.1536936](https://doi.org/10.1080/00221546.2018.1536936)

Kahanamoku, S., Alegado, R. A., Kagawa-Viviani, A., Kamelamela, K. L., Kamai, B., Walkowicz, L. M., & Neilson, H. (2020). A Native Hawaiian-led summary of the current

- impact of constructing the Thirty Meter Telescope on Maunakea. *arXiv preprint arXiv:2001.00970*.
- Kanim, S., & Cid, X.C. (2020). Demographics of physics education research, *American Physical Society, 16*(2). DOI: 10.1103/PhysRevPhysEducRes.16.020106
- Lee, J., Solomon, M., Stead, T., Kwon, B., & Ganti, L. (2021). Impact of COVID-19 on the mental health of US college students, *BMC Psychology, 9*, Article 95.
<https://doi.org/10.1186/s40359-021-00598-3>
- Leyva, L. A., & Joseph, N. M. (2023). Intersectionality as a lens for linguistic justice in mathematics learning. *ZDM – Mathematics Education, 1–11*.
<https://doi.org/10.1007/s11858-023-01489-0>
- McCluney, C.L., Robotham, K., Lee, S., Smith, R., & Durkee, M. (2019). The Costs of Code-Switching, *Harvard Business Review*. <https://hbr.org/2019/11/the-costs-of-codeswitching>
- Redish, E. F. (2012). The role of context and culture in teaching physics: The implication of disciplinary differences. *arXiv preprint arXiv:1207.4840*.
- Redish, E.F., & Kuo, E. (2015). Language of Physics, Language of Math: Disciplinary Culture and Dynamic Epistemology. *Sci & Educ 24*, 561–590. <https://doi.org/10.1007/s11191-015-9749-7>
- Rodriguez-Campo, M. (2021). Testimonio in education. In *Oxford Research Encyclopedia of Education*.
- Stinson, D. W. (2004). Mathematics as “gate-keeper” (?): Three theoretical perspectives that aim toward empowering all children with a key to the gate, *The Mathematics Educator, 14*(1), 8–18.

Quick, T. (2020). The Making of a New Race in the Early Twentieth Century Imperial Imaginary, *The Historical Journal*, 63(5), 1-26. DOI: 10.1017/S0018245X20000047

Quicke, J. (2010). Narrative strategies in educational research: reflections on a critical autoethnography. *Educational Action Research*, 18(2), 239-254. DOI: [10.1080/09650791003741582](https://doi.org/10.1080/09650791003741582)

Yosso, T.J. (2005). Whose culture has capital? A critical race theory discussion of community cultural wealth, *Race Ethnicity and Education*, 8(1), 69-91. DOI: 10.1080/1361332052000341006

CalcConf2023 Paper style template: type your title here (the style is called heading 1, do not capitalize words)

Brian Faulkner

Milwaukee School of Engineering, USA; faulkner@msoe.edu

Abstract: Calculus forms a critical mathematical foundation for study in engineering. Calculus courses are required as prerequisite to nearly every engineering class; failure in calculus is devastating to students' graduation timeline. The way ideas manifest themselves in the context of engineering coursework. This talk illustrates the differences between mathematical training of engineering students and engineering study via three examples: The rigor of limits and continuity in engineering coursework, the difficulty of derivatives in engineering coursework, and the units of measure of integrals in engineering coursework.

Introduction: Calculus in engineering practice

Calculus unquestionably holds a key position in the study, development, and practice of engineering. The pioneering work using calculus to describe the constructed world by the Bernoulli's and Euler developed beam theory in 1750 using the foundations of calculus, which a century later was used to design the iconic feat of engineering, the Eiffel tower. Around the same time, calculus was used to develop the elementary theory of fluid dynamics. The theories of electromagnetism, transmission lines, yield of soil in construction, radio communication, plastic failure, nuclear energy and nearly all other engineering disciplines require calculus to access the theoretical foundations of study.

Most engineers do not use calculus daily, but their technical activities often have calculus in the background, often such that the engineers themselves do not recognize they are using calculus in their work. [citation] The calculus in engineering is often shunted into tables of pre-computed properties of continuous shapes that can be looked up, but these tables are constructed from calculus.

Background: Calculus in engineering education

Calculus forms the theoretical bedrock for most engineering disciplines, and most engineering programs require one and a half to two years of study in calculus. For example, take the curriculum in electrical engineering in figure 1. Nearly every course of study requires calculus as a direct or indirect prerequisite. On-time graduation is strongly dependent on performance in calculus, as calculus sits at the root of several very long prerequisite course chains. A single failure at any point along this progression will inevitably delay student graduation. For this reason, engineering deans watch the progression in calculus closely, occasionally launching initiatives to teach calculus within the college of engineering. The longest in this example is 8 trimesters long:

Calculus 1 > Calculus 2 > Calculus 3 > Differential Equations > Transient Circuits > Electronics 1 > Electronics 2 > Senior Design.

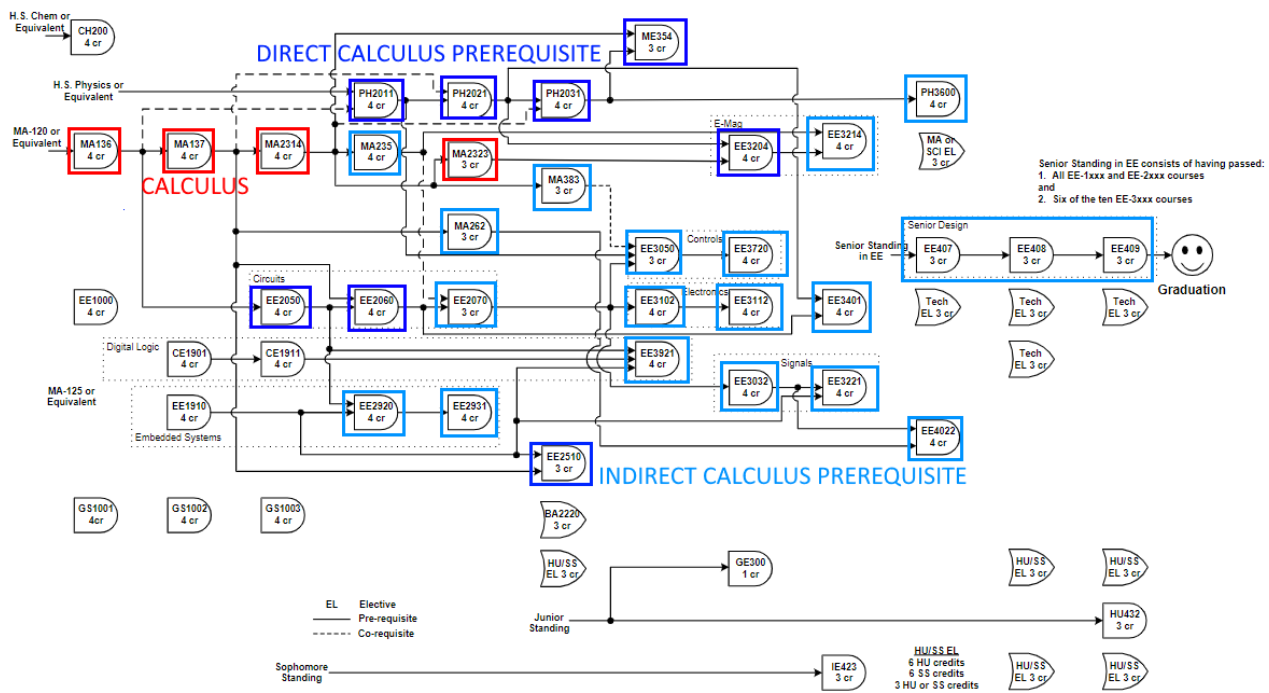

Figure 1: Calculus prerequisites in an electrical engineering curriculum

Engineering students emerge from calculus often able to do a few narrowly defined computations, but struggle to interpret the results of calculations. Even interpreting whether an integral has the correct sign when placed in a physical context is challenging for students. Due to these challenges, many engineering faculty teach classes that require calculus as a prerequisite, but without actually requiring any calculus of their students (Ferguson, 2012). Some faculty openly admit that their courses require calculus as prerequisite only to ensure that students have proper algebra skills, not because the course requires any calculus at all (Faulkner, 2018).

Engineering students frequently bemoan the lack of applications to their engineering ambitions encountered in introductory calculus (Biehler, 2014). Many calculus classes are taught purely in the abstract, with many books containing few applications, and the applications that are included being often inauthentic camouflage for standard abstract tasks (Wijaya, van den Heuvel-Panhuizen, & Doorman 2015). This phenomenon is striking given the origins of the subject in describing the mechanical universe mathematically.

This work focuses on introductory level first and second-year engineering courses, which list calculus as a direct prerequisite. More advanced third and fourth-year engineering courses apply more calculus, but by this stage any attrition of engineering students has already occurred. This paper draws heavily from my PhD dissertation on the mathematical education of engineers. Two main differences present themselves in the way numbers are used in engineering and the way they are learned in mathematics courses: units and orders of magnitude, the “mathematics of physical quantities” (Biehler, 2015). The properties of numbers manifest in all three of the major application areas of calculus in engineering.

Limits and continuity in engineering

Limits as covered in many Calculus I classrooms do not reflect their use in engineering. The informal use of infinitesimal quantities, $e^{-\infty} \approx 0$ is commonplace in engineering lectures. Most limits in early engineering classes can be handled with more informal notions of limits. Formal use of limits doesn't become necessary until later engineering courses such as signal processing. The most complex limit that is evaluated in a sophomore-level circuit theory course is this high-frequency limit of a circuit response:

$$|H(\omega = \infty)| = \lim_{\omega \rightarrow \infty} \frac{\omega}{\sqrt{\omega^4 + A\omega^2 + B}} \approx \frac{\omega}{\sqrt{\omega^4 + A\omega^2}} \approx \frac{\omega}{\sqrt{\omega^4}} \approx \frac{1}{\omega} \approx 0$$

The vague idea of a limit defines big-O notation in computer science, but the use of limits is restricted to a tier list of faster and slower functions. This requires conceptual knowledge of the idea of a limiting process, but practiced skill in evaluating complex limits is not required to use the idea correctly.

In engineering, continuity is important as a check on physical possibility, and discontinuity implies specific physical conditions. Capacitor voltage can never be discontinuous, a discontinuous shear curve implies a point load at the location of the discontinuity, etc. In calculus classrooms this is a property that is checked (Czocher, Tague & Baker, 2013), but the consequences of a presence or lack of continuity are less emphasized.

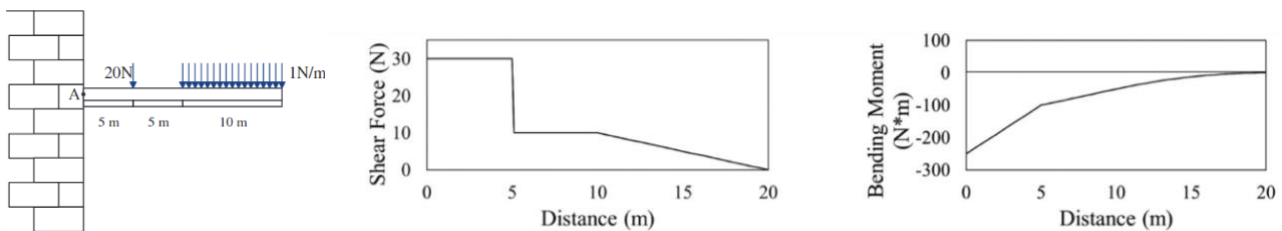

Figure 2: Shear and bending moment diagrams (Johnson-Glauch & Herman, 2017)

In engineering the notion of continuity emerges as an expression of physical constraints obeyed by certain systems. Certain physical quantities are allowed to be discontinuous; others are not. Continuity is used as a check on the reasonableness of a calculation. For example, the shear in a beam is permitted to be discontinuous only at the location of a point load.

In upper division courses such as signal processing, a few trickier limits are sometimes evaluated, such as the hole-filling of the discontinuity of $\text{sinc}(x) = \sin(x)/x$, but these are rare.

The “impulse” or “delta” function $\delta(t)$ or $\delta(x)$, by contrast, occurs frequently in engineering coursework, but is only very awkwardly described in terms of limit-based real analysis. This function occurs in signal processing, control systems, electromagnetic field theory, and other areas. In the shear and bending moment example above, the point-like load of 20 N is a delta function. Only at the location of this concentrated load can the shear be discontinuous, as it is at $x=5$ m. The bending moment can only be discontinuous at the location of point-like twisting forces, and since none occur in the beam, the bending moment diagram must be continuous.

Derivatives in engineering: Interpretation of simple functions

In engineering, only rather simple functions and their derivatives are frequently encountered: sines, cosines, polynomials, exponentials with linear terms inside. For example, the complexity of function that must be differentiated in engineering coursework is generally very simple, only lines, sinusoids, and exponentials are used regularly, especially in lower-level engineering coursework. In this sense, the topical coverage of introductory calculus is “overkill” compared to the needs of engineering curricula. [alejandro's paper]

By contrast, in engineering it is far more common and vital to interpret the consequences of derivatives. For example, consider the Lennard-Jones potential in materials engineering,

$$E(r) = \frac{A}{r^{12}} - \frac{B}{r^6}$$

Engineering faculty report that though students might be able to evaluate the derivative, they cannot extract from that derivative the physical meaning, that the location of its zero is the point of equilibrium. Students in engineering who are capable of performing

The most challenging derivative encountered in a typical vibrations or circuit theory course is of the form $\frac{d}{dt}(\sin(3t)e^{-2t})$

The completely robust set of techniques to evaluate derivatives of any function, no matter how tangled such as $\frac{d}{dx}\sin(\cos(\tan(x)))$, is in a sense overdeveloped compared to the needs of engineering students. In engineering coursework, derivatives usually act on elementary functions, with one application of the chain rule needed for a linear term inside.

By contrast to evaluation of such derivatives analytically, recognizing the units of measure imparted by the derivative operation itself is essential to using calculus correctly in engineering. For example, consider this typical engineering task in an AC circuits course:

The current flowing through an 300 mH inductor is $i(t) = 200[\text{A}]\sin(314[\text{rad/s}]t)$, compute the resulting terminal voltage using $v(t) = L \frac{d}{dt}i(t)$.

In this task, application of the chain rule and multiplication by the angular frequency of 314 rad/s provides the change of units. Handling of the dimensions of inverse time associated with a time derivative is emphasized in such courses. In the same course, the question might be posed graphically:

During what interval is the greatest voltage applied to the 508 H inductor the greatest in Figure 3?

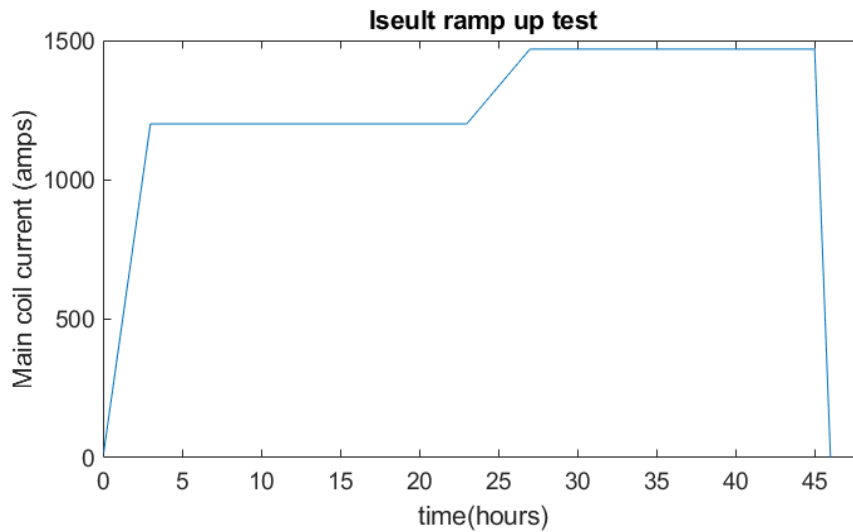

Figure 1: Voltage waveform applied to MRI magnet

In such instances, calculus itself is not required since the function is piecewise linear, slopes suffice, but students must be able to translate between an equation given in derivative form to the computation done in simple algebra.

Integrals in engineering: Piecewise functions and units

In the construction and use of integrals in engineering, the “informal infinitesimals” method [Ely, 2019] is alive and well. Almost any engineering textbook makes extensive use of these (Non rigorous) methods to develop physical results. These infinitesimals are called “control volumes” in some parts of engineering, practicing how to set up and use these control volumes is a standard unit in any fluid mechanics class. Consider this typical application of integrals with an example from power electronics.

A MOSFET is an electronic switch, A gate charge of 8 nC is needed to turn the switch on, which requires an input of electrical energy by the equation $E = \int_{q=0}^{q=8\text{nC}} V(q) dq$. Compute the necessary energy for the MOSFET in Figure 4.

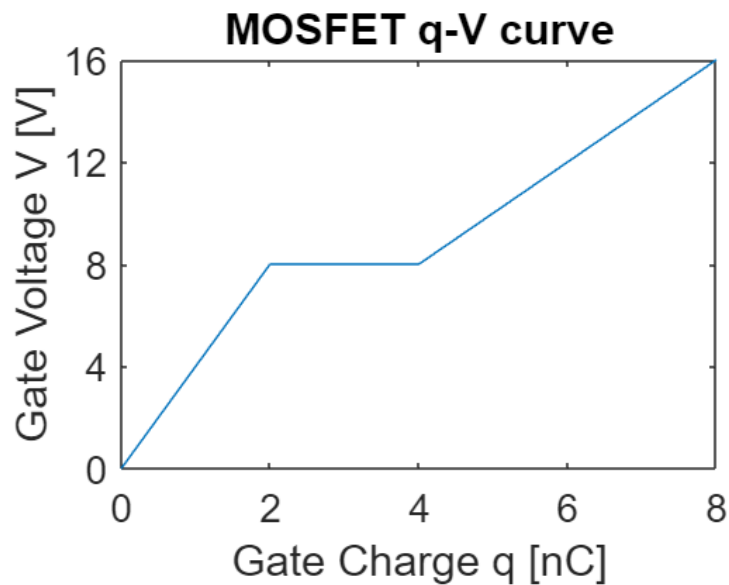

Figure 4: Piecewise linear function to be integrated

This function has physical units (nanocoulombs on the x axis, volts on the y axis), so the student must interpret that the integral is the area under the curve, and that this area has units of nanojoules, the product of the x and y axis units. Engineering students leave calculus inexperienced at handling the physical units and orders of magnitude required by this mathematical task. The function is not given analytically, but graphically. It is not a single function, but defined piecewise. The pieces themselves are simple linear functions, which is very common in engineering. The actual calculus need not be performed, just the area under the curve. However, interpretation of the graph certainly requires calculus concepts, though not calculus procedural skills. Many concepts in engineering that use calculus in concept do not use them in implementation, the calculus is avoided by using simpler methods, or referring to tables of pre-computed forms. An astute student would estimate that the area must be a bit larger than half the product of the extreme values. Additional examples include centroids in the study of statics, torsional moments of area in mechanics of materials, or tables of laplace transformations in controls. Each of these requires a conceptual knowledge of calculus to understand, but the calculus computations are not performed by the student.

The functions that must be integrated in introductory engineering coursework are very simple, but often piecewise-defined. Piecewise-linear functions must be integrated frequently in introductory circuits or statics courses, only rarely is a function more complex than the exponential integrated.

When constructing integrals to describe behavior of physical systems, the “multiplicative based summation” interpretation is the dominant interpretation of the integral. A small differential “chunk” of the system is chosen, and the “weight” of that small piece is added up. Depending on whether the “chunks” are summed in time or in space, different verbs are used to describe the integration action, which correspond to the “adding up pieces” and “rate accumulation” interpretations of the integral detailed in Ely’s work.

Consider the task in Figure 5 where students must choose the correct bending moment from the shear diagram, where the shear v must be integrated, but with the constraint that the shear must

have value 0 at the end of the beam, which experiences no stress. The integral's "initial condition" does not occur at the joint at the origin, but at the extreme end of the beam.

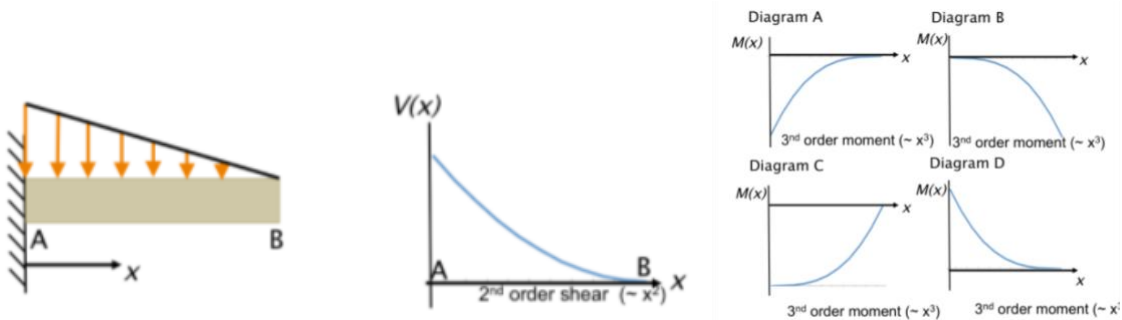

Figure 5: Typical integration task in statics

Opportunities for Collaboration

Students would certainly perform better at application tasks in following coursework if the task of application were practiced in calculus. But from where will this diversity of application tasks come from? Not from existing textbooks (Wijaya, van den Heuvel-Panhuizen, & Doorman 2015), these have few applications, and few of the few are authentic. The only text I know of with a true abundance of applications is that of Rattan and Klingbeil (2021), but this text is mostly pre-calculus. What can a motivated and enterprising mathematics faculty member do? By no means can a typical faculty member suddenly become an expert in application areas of not only every subdiscipline of engineering, but every subdiscipline of chemistry, physics, business, biology, and every other discipline that depends on calculus. Such study would take multiple lifetimes. The client disciplines frequently complain of the lack of applications but do little to provide their expertise to their mathematical colleagues in a useful form: simplified, relevant tasks suitable for a novice. As stated by Scanlan (1985):

“To be effective and useful the design of mathematics courses for engineering students must involve a continuous and informed dialogue between engineering and mathematics departments to which each must contribute fully. The process of dialogue is essential since neither must be the dominant partner. The difficulties usually arise not in deciding what is to be taught but how and at what level. This is where the engineering department must have a clear understanding of what is needed and be able to communicate this effectively to the mathematicians.”

This communication continues to be a struggle 40 years later. On even a single campus, nobody in engineering knows what mathematics faculty are actually doing in class, and make assumptions based on their own university experiences. Some question the utility of even trying to provide applications, when no one application has any chance of interesting every student, or even a majority of students (Corey, 2018).

Here I disagree with Corey based on my personal experience teaching circuits-for-nonmajors. I have a classroom of students who picked the not-electricity major on purpose, and it is my job to teach them about electricity. I have disinterested mechanical engineers, civil engineers, biomedical engineers, and computer engineers. I fight a similar rhetorical battle familiar to any calculus

instructor (speaking as a former high school calculus teacher); I have a diverse audience that firmly but incorrectly believes that what I teach is irrelevant to their career ambitions. My experience presenting applications has been that authentic applications presented in sufficient number can be effective in motivating students to engage, but constructing these application tasks has taken great input from my colleagues. I am not an expert in biomedical instrumentation, mechanical controls, or civil structural health monitoring. Donations of example contexts, laboratory manuals of more advanced coursework, and lunchtime chats have helped develop a rich set of applications, with the course numbers for when this knowledge will reappear in the students' major coursework.

The introductory calculus class could teach substantially less topical content and still meet the prerequisite technical knowledge for introductory engineering coursework. Many topics (not concepts) do not reach application in engineering until far later in the curriculum, which offers flexibility to the mathematics faculty. Many topics decreased sharply in use with the advent of powerful computational tools, so the time devoted to these topics (such as, for example, partial fractions expansion or convergence tests) can be repurposed. Much of what engineering faculty desire is a general level of mathematical competence from calculus, so the exact topic selection is less critical than it first appears.

Calculus is a beautiful subject that describes our beautiful universe. I hope that collaboration between disciplines can lead more students to this view, or at least to acquiesce to its incredible usefulness.

References

- Biehler, Rolf, Jörg Kortemeyer, and Niclas Schaper. "Conceptualizing and studying students' processes of solving typical problems in introductory engineering courses requiring mathematical competences." CERME 9-Ninth Congress of the European Society for Research in Mathematics Education. 2015.
- Ferguson, L. J. (2012). Understanding calculus beyond computations: A descriptive study of the parallel meanings and expectations of teachers and users of calculus. Indiana University.
- Ely, Robert. "Teaching calculus with infinitesimals and differentials." *ZDM—Mathematics Education* 53 (2021): 591-604.
- Ely, Robert. "Definite integral registers using infinitesimals." *The Journal of Mathematical Behavior* 48 (2017): 152-167.
- Johnson-Glauch, Nicole, and Geoffrey L. Herman. "Engineering representations guide student problem-solving in statics." *Journal of Engineering Education* 108.2 (2019): 220-247.
- Scanlan, J. O. "The role of mathematics in engineering education: an engineer's view." *International Journal of Mathematical Education in Science and Technology* 16.3 (1985): 445-451.
- Czocher, Jennifer A., Jenna Tague, and Greg Baker. "Where does the calculus go? An investigation of how calculus ideas are used in later coursework." *International Journal of Mathematical Education in Science and Technology* 44.5 (2013): 673-684.

- Wijaya, A., van den Heuvel-Panhuizen, M., & Doorman, M. (2015). Opportunity-to-learn context-based tasks provided by mathematics textbooks. *Educational studies in Mathematics*, 89, 41-65.
- COREY, D. When Will I Ever Use This? An Essay for Students Who Have Ever Asked This Question in Math Class. *Math Horizons*, 22(2), p. 34, 2018
- Rattan, K. S., Klingbeil, N. W., & Baudendistel, C. M. (2021). *Introductory Mathematics for Engineering Applications*. John Wiley & Sons.

Foundations of calculus in chemistry: Where and how calculus is used in the chemistry undergraduate curriculum.

Marcy H. Towns

Purdue University, USA; mtowns@purdue.edu

Introduction to the structure of the discipline of chemistry

In order to come to an interdisciplinary understanding of the field of chemistry, it would be useful to describe the structure of the discipline. In particular, it would be illustrative to describe undergraduate chemistry in relation to physics, biology, and mathematics for the purposes of this conference.

Chemistry is often described as the central science because it has applications and synergies with biology, physics, earth and planetary sciences, medicine, geology, plant science, and environmental science as shown in Figure 1.

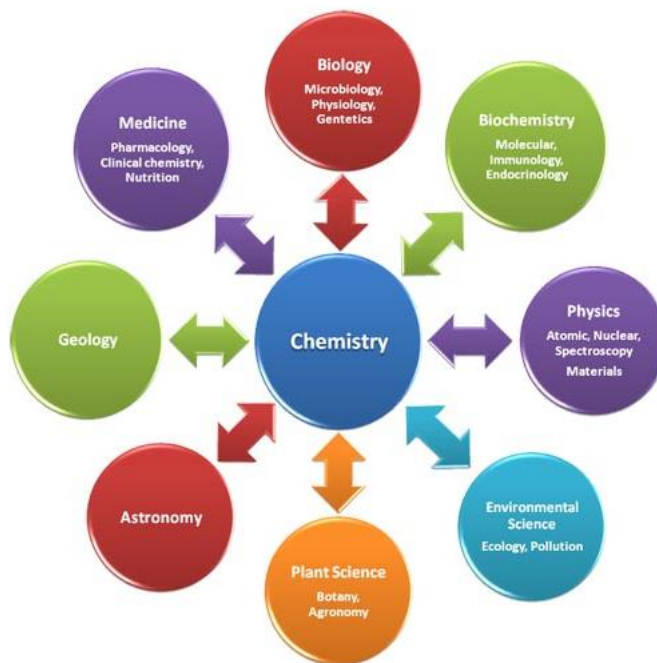

Figure 1: Chemistry, the central science, with applications and connections to a variety of other science areas (Shapley, 2011)

Outwardly, chemistry has connections to nearly every science one can imagine since everything around us is made up of atoms and molecules. Inwardly, chemistry as a discipline is comprised of five subdisciplines with overlap between them (American Chemical Society, n. d.)

- Analytical chemistry focuses on obtaining measurements, analyzing, and interpreting them in such a way that it informs chemists about the composition and structure of matter. Typically, analytical chemists use instruments to carry out qualitative and quantitative analyses including separations; Collect, identify, isolate, and preserve samples; and they may validate and verify results through standardized methods including calibration.
- Biochemistry lies at the interface of biology and chemistry, and indeed is sometimes called biological chemistry. This subdiscipline explores the chemistry and chemical processes of living systems including plant, animal, and human systems. Often these chemists study a small part of a larger and more complex chemical/biological system.
- Inorganic chemistry is the study of metals, minerals, and organometallic compounds. For example, an inorganic chemist may study how to remove heavy metals from waste water, or drinking water. They also study how to create new compounds with specific desirable properties (conductors, adhesives, etc.). Often, they work with other chemists and engineers to solve problems.
- Organic chemistry is the study of carbon containing compounds including the structure, properties (function), and reactivity. There are many organic compounds simply composed of carbon and hydrogen, but organic compounds may contain a few other elements including oxygen, nitrogen, sulfur, and phosphorous (for example proteins and DNA). Organic chemistry is a creative field that includes the synthesis of molecules (pharmaceuticals), agricultural chemicals, personal care products (cosmetics and cleaning solutions), fuels, plastics, etc.
- Physical chemistry uses physics and mathematics to describe the interaction of atoms and molecules. These chemists are often engaged in physically characterizing and testing properties of materials. Among the subdisciplines of chemistry, this is the one that leverages the application of mathematics, sometimes on very large data sets, to reveal information about processes (protein folding for example) and materials.

Undergraduate curriculum in chemistry

Perhaps unsurprisingly the chemistry undergraduate curriculum is reflective of these five disciplines. The American Chemical Society (ACS) approves baccalaureate chemistry programs and has coursework guidelines for the undergraduate program which include chemistry, physics, and mathematics courses (2023 ACS Guidelines for Undergraduate Chemistry Programs: Approved, n.d.). Table 1 lists required coursework in these areas noting which courses have an associated laboratory. Table 2 lists an 8-semester sequence of course work which serves as an example of the cadence across four years (note there are more required courses for graduation, usually totally at least 120 hours of coursework). The physics courses are calculus-based, and it is common to complete the required calculus courses early in the plan of study.

Table 1: Required courses for an ACS approved degree highlighting chemistry, physics, and mathematics. The number in front refers to the number of those courses in a semester (16 week format)

Chemistry lecture with associated laboratory	Chemistry lecture, no laboratory	Chemistry, laboratory only	Other requirements

2 General Chemistry	1 Biochemistry	1 inorganic laboratory (synthesis)	2 Physics (calculus based: modern mechanics and electricity and magnetism)
2 Organic Chemistry	2 Inorganic chemistry		3 Calculus
2 Analytical Chemistry			1 Linear algebra**
2 Physical Chemistry			1 Differential equations**

*Note: Linear algebra and differential equations are often required by universities or colleges, but are not required by the ACS. They may also be taken as a single course.

Table 2: Sample semester by semester course schedule

Year	Fall	Spring
1	General Chemistry + lab	General Chemistry + lab
	Calculus I	Calculus II
		Physics I + lab
2	Organic Chemistry + lab	Organic Chemistry + lab
	Calculus III	Inorganic I
	Physics II + lab	Differential equations
3	Analytical I + lab	Physical Chem. II + lab
	Physical Chem. I + lab	Linear algebra
4	Biochemistry	Inorganic II
	Analytical II + lab	Inorganic lab

For students interested in a biochemistry degree, students complete the required calculus sequence, but not differential equations or linear algebra. Biology coursework in cell biology with laboratory and genetics with laboratory are required. Concomitant with the increase in

biology coursework requirements there is a decrease in chemistry coursework such as removing Analytical II with laboratory and inorganic laboratory from the four-year curriculum.

How Did Calculus Become Required in the Chemistry Curriculum?

Inadequate experience in mathematics is the greatest single handicap in the progress of chemistry in America. (Daniels, 1931 p. 257, italics in the original)

History is a complex and nuanced endeavor, and to shorten the history of the rise of the importance of mathematics in chemistry in the United States to a few brief paragraphs is to risk omitting nuanced details. But that is the challenge and with that caveat the story shall unfold and the contributions of Farrington Daniels highlighted.

The transformation of American chemistry from a heavy experimental emphasis towards a more theoretical understanding can be traced back to 1880-1930. At that time one of the leaders of US science was Dr. Theodore Richards of Harvard University, who won the Nobel Prize in Chemistry in 1914 for “accurate determinations of the atomic weight of a large number of chemical elements” (The Nobel Prize in Chemistry 1914, n.d.). Thus, the culture of chemistry in the US gave greater privilege to laboratory measurements and experiments while de-emphasizing theoretical pursuits that required advanced mathematics such as calculus and differential equations. However, the discoveries in chemistry and physics in thermodynamics, electricity, magnetism, kinetic molecular theory, statistical thermodynamics and quantum mechanics during this time period required mathematical prowess to interpret experiments and to drive forward understanding of the molecular world.

Farrington Daniels received his doctorate from Harvard working in Richards laboratory in 1914 and did this without taking calculus at any point (Servos, 1986; Alberty, 1994). World War I scuttled a post-doctoral appointment in Germany, and after the war Daniels was appointed as an assistant professor of chemistry at the University of Wisconsin – Madison (Alberty, 1994). He was tasked with teaching physical chemistry to undergraduates and graduates and developing and implementing a course to teach calculus to chemists.

These early career experiences inspired Daniels to be a leader in revising the preparation of chemists in the United States. In particular there are two paradigm changing events and a series of articles published in the *Journal of Chemical Education* that are illuminating (Daniels, 1929; Daniels, 1958; Daniels 1931). First, he published “Mathematical Preparation for Physical Chemistry in 1928 (Daniels, 1958; Daniels, 1928). Second, in the spring of 1931, he organized a symposium on “The Teaching of Physical Chemistry” during the American Chemical Society meeting, which attracted an audience of 600 chemists (Daniels, 1931). He was the leader in chemistry that sought to change training to include calculus noting “Calculus is absolutely essential” and “Partial differentiation is the backbone of thermodynamical treatment . . . (and) The physical significance of partial differentiation is the important thing for the student to master” (Daniels, 1931, p. 257). One statement he made in his introductory remarks leaves little doubt as to the fear of being cut-off from world class science: “Somehow our chemists must be better trained in mathematics or we shall be completely outclassed by our chemist friends in Europe” (Daniels, 1931, p. 257).

In 1936, the American Chemical Society (ACS) formed the committee which is now known as the Committee on Professional Training to carefully consider the appropriate training for chemists at the baccalaureate, masters, and doctoral levels and to consider the accrediting of

schools (Billings, 1950). From 1936 to 1939 the committee worked with the chemistry community to generate objective standards of training for chemists at the undergraduate and graduate levels. In 1939, the first set of standards was proposed for the bachelor's degree and two years of mathematics course work including one year of differential and integral calculus was required. Across the decades the ACS has consistently required calculus as part of its ACS certified degree program. In 2023, three semesters of calculus are required and many students go on to take linear algebra and differential equations (2023 ACS Guidelines for Undergraduate chemistry Programs: Approved, n.d.).

Where are calculus and calculus concepts used in undergraduate chemistry?

Chemistry is fortunate as a field that a group of scholars have been engaged for more than 10 years with the American Chemical Society Examinations Institute developing what are known as the Anchoring Concepts Content Maps (ACCMs) in chemistry which covers general chemistry, organic chemistry, inorganic chemistry, and physical chemistry (Murphy, et al., 2012; Holme & Murphy, 2012; Raker et al., 2013; Holme, Luxford, & Murphy, 2015; Marek et al., 2018; Holme et al., 2018; Holme et al., 2020a, Holme et al., 2020b). The Biochemistry ACCM was delayed due to COVID and should appear in 2023. These content maps are anchored to the ten big ideas in chemistry²⁰ and the ACCMs were created and validated through a process of engagement with the chemistry community.

Although originally created to help the ACS Exams institute align its examination items to the ten big ideas and to serve as a resource to departments engaged in assessment efforts, for the purposes of this conference the ACCMs can be used to identify where calculus is used in the curriculum and what calculus concepts are applied to problems in chemistry.

Table 3 lists each chemistry area ACCM and the big idea and enduring ideas in the curriculum where calculus is used. One of the anchoring concepts based upon the 10 big ideas is "kinetics" which is a study of rates in chemistry (the rates of chemical reactions) (American Chemical Society SOCED Report, 2005). The mathematical models used to describe rates of reactions are derived by integrating the rate equation that represents the way concentrations of reactants change with time. However, often in lower division courses (the first two years of university) the model is presented and used, but the derivation of the model may not be explicitly shown and may not be an assessed learning outcome. Thus, although Kinetics is listed for general, organic, and inorganic chemistry in Table 3, the use of calculus to obtain the integrated rate law is dependent upon the instructor.

Based upon this analysis, kinetics or rates of reactions is the only big idea where calculus is used in the lower division curriculum (first two years). In upper division course work in analytical chemistry and especially physical chemistry, calculus is used more frequently to describe, model, and elucidate chemical phenomena embodied in the ten big ideas.

To further understand the use of calculus in undergraduate chemistry it may be helpful to also note where the results of mathematical ideas are used to help students learn about a big idea, but the pure mathematics is not explored. For example, bonding is a fundamental concept and big idea where atoms interact via electrostatic forces to form chemical bonds. Bonding can be modeled mathematically using calculus and higher-level mathematics, and the results are often displayed graphically. In lower division coursework such as general chemistry and organic

chemistry the focus is on gaining chemical insights from the graphical representations, rather than the mathematical details.

Table 3: Content areas by course work topic where calculus is used. The right-hand column notes the anchoring concept, which is one of the ten big ideas in chemistry, an enduring idea in italics, and then a sub-disciplinary articulation in some cases.

ACCM area	Anchoring concept, <i>enduring ideas</i> , or (sub-disciplinary articulation) that use calculus.
General Chemistry (Holme & Muprhy, 2012), Organic Chemistry (Raker et al., 2013), and Inorganic Chemistry (Marek et al., 2018)	Kinetics: <i>Chemical change can be measured as a function of time; Empirically, experimentally, derived rate laws summarize the dependence of reaction rates on concentrations of reactants and temperatures</i>
Inorganic Chemistry (Marek et al., 2018)	Bonding: <i>A theoretical construct that describes chemical bonding utilizes the construction of molecular orbitals for the bond based on overlap of atomic orbitals on the constituent atoms; (Molecular orbitals are formed by overlapping atomic orbitals that have the same symmetry)</i>
Analytical Chemistry (Holme et al., 2020b)	Kinetics: <i>Chemical change can be measured as a function of time; Empirically (experimentally), derived rate laws summarize the dependence of reaction rates on concentrations of reactants and temperatures</i>
	Equilibrium: <i>Thermodynamics provides mathematical tools to understand equilibrium quantitatively; (Equilibrium constants are temperature dependent and the variation can be modeled using the van't Hoff equation)</i>
Physical Chemistry (Holme et al., 2018)	Atoms: <i>Electrons play the key role for atoms to bond with other atoms: Atomic wavefunctions describe an atom's electrons and these functions include quantum numbers</i>
	Bonding: <i>Because protons and electrons are charged all models of bonding are based on electrostatic forces; Because chemical bonds arise from sharing of negatively charged electrons between positively charged nuclei, the overall electrostatic interaction is attractive; A theoretical construct that describes chemical bonding utilizes the construction of molecular orbitals for the bond based on overlap of atomic orbitals on the constituent atoms; Different types of approximations, including variational</i>

	<i>theory or perturbation theory, may be used to solve quantum mechanical problems</i>
	<i>Structure/Function: Electronic, vibrational, and rotational motions are associated with energy levels and transitions between levels provide important insight into molecular behaviors; Rotational and vibrational spectroscopy are sensitive to the atoms' nuclear mass via the I (moment of inertia, and B (rotational constant) or reduced mass; Theoretical models are capable of providing detailed structures for whole molecules based in energy minimization methods.</i>
	<i>Intermolecular Forces: For condensed phases that are not structures of extended chemical bonds the physical properties of the state are strongly influenced by the nature of the intermolecular forces (The Clausius-Clapeyron equation describes phase equilibrium in terms of macroscopic variables.)</i>
	<i>Reactions: In chemical changes, matter is conserved and this is the basis behind the ability to represent chemical change via a balanced chemical equation (The extent of a reaction, ξ, can be defined in terms of differential changes in amounts of substances present.)</i>
	<i>Energy and Thermodynamics: Thermodynamics provides a detailed capacity to understand energy change at the macroscopic level.</i>
	<i>Kinetics: chemical change occurs over a wide range of time scales; Empirically derived rate laws summarize the dependence of reaction rates on concentration of reactants and temperature; Most chemical reactions take place by a series of more elementary reactions, called the reaction mechanism; An elementary reaction requires that the reactants collide (interact) and have both enough energy and appropriate orientation of colliding particles for the reaction to occur.</i>
	<i>Equilibrium: Thermodynamics provides mathematical tools to understand equilibrium quantitatively</i>
	<i>Experiments, measurement, and data: Chemistry is generally advanced via empirical observation</i>

	<p>Visualization; <i>Many theoretical models are constructed at the particulate level, while many observations are made at the macroscopic level.</i> (Quantum mechanical models include the premise by which probabilities lead to experimental observations). (Mathematical relationships are useful in deriving equations that define various models). <i>Macroscopic properties result from large numbers of particles, so statistical methods provide a useful model for understanding the connections between these levels; Quantitative reasoning within chemistry is often visualized and interpreted graphically</i></p>
--	---

Examples of how calculus is used in the undergraduate curriculum

To understand how calculus is used in the undergraduate chemistry curriculum a deeper dive into the discipline is required. In the text that follows symbols that are commonly used in the discipline appear. Box 1 serves as a guide to these symbols and may aid in the readability of the following sections. The hope is to make the text less like alphabet soup.

Box 1: Terms		
A = Helmholtz Energy	G = Gibbs Energy	H = Enthalpy
K = rate constant	K = Equilibrium constant	P = Pressure
R = Gas constant	T = Temperature	U = Energy
V = Volume		

Based upon Table 3, the big idea of Kinetics or rates of chemical reactions is a part of every course throughout the curriculum. Here differentials are used to express the rate equation (called a rate law in chemistry) showing the relationship between the rate and the concentration of reactants. When the equation is integrated the relationship between concentration and time is revealed. This integrated rate law is used to determine the amount of reactant present after a certain time t .

Relationship between reactant concentration and time.

Consider the reaction where a reactant B goes to products. A chemist would denote this as:

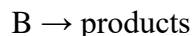

The rate of the reaction would be expressed as the equation below where [B] is the concentration of reactant B and k is the rate constant that is independent of time. The value of x is known as the order of the reaction.

$$\text{Rate} = k[B]^x$$

The three most common cases discussed in coursework are zero, first, and second order reactions. Because reactants are being consumed in a chemical reaction, the rate of change in

concentration of a reactant with time is a negative quantity and a negative sign is added to the rate equation. The three common cases are shown below with the associated rate equation, the integration, and the final integrated rate equation in a $y = mx + b$ format.

	<u>Zero</u>	<u>First</u>	<u>Second</u>
Rate equation	$\frac{-\Delta[B]}{\Delta t} = k$	$\frac{-\Delta[B]}{\Delta t} = k[B]$	$\frac{-\Delta[B]}{\Delta t} = k[B]^2$
Integration	$\int d[B] = \int -k dt$	$\int \frac{d[B]}{[B]} = \int -k dt$	$\int \frac{d[B]}{[B]^2} = \int -k dt$
Integrated rate equation	$[B] = -kt + [B]_0$	$\ln[B] = -kt + \ln[B]_0$	$\frac{1}{[B]} = kt + \frac{1}{[B]_0}$

In each equation $[B]_0$ is in the initial concentration of reactant B at time $t = 0$, and $[B]$ is the concentration of reactant B at time t . Thus, these equations allow for the calculation of reactant left after the reaction has proceeded for some time t if the reaction order is known. The order is an experimentally determined quantity and it is not given by the balanced overall chemical equation. The analysis of experimental data is guided by these integrated rate laws and it is a common undergraduate experiment to determine the order of a reaction.

Differentials and integration to reveal relationships

Table 3 demonstrates that calculus is used in all ten big ideas in the physical chemistry curriculum. There are cases in which measured experimental variables, such as temperature, are related to constants or properties of substances are important in describing the system and or its behavior. Table 4 shows three equations that are used in a first semester physical chemistry course. The equations are often derived and students may be assessed on the derivation and or the integrated equations may be used to analyze experimental data to make claims about chemical substances or systems. In all cases the students must blend their understanding of chemistry and the quantities under consideration with the mathematics from calculus that they wish to use.

Table 4: Examples of three equations from three different big ideas used in a first semester chemistry course. They are shown in the differential form and integrated form and a brief explanation of their importance is given

Equation name and Big Idea area	Differential form	Integrated form	Importance
Van't Hoff equation (equilibrium in both p. chem and analytical)	$\frac{d \ln K}{d(\frac{1}{T})} = -\frac{\Delta_r H^\ominus}{R}$	$\ln K_2 - \ln K_1 = -\frac{\Delta_r H^\ominus}{R} (\frac{1}{T_2} - \frac{1}{T_1})$	Assuming $\Delta_r H^\ominus$ doesn't vary over the change in T, one can predict K, equilibrium constants from known

			thermodynamic data.
Clausius-Clapeyron (Intermolecular forces)	$\frac{d \ln P}{dT} = -\frac{\Delta H_{vap}^{\ominus}}{RT^2}$	$\ln P_2 - \ln P_1 = -\frac{\Delta H_{vap}^{\ominus}}{R} \left(\frac{1}{T_2} - \frac{1}{T_1} \right)$	Relates temperature dependence of vapor pressure to the heat of vaporization
Gibbs-Helmholtz (Energy and Thermodynamics)	$\left(\frac{\partial \left(\frac{\Delta G^{\ominus}}{T} \right)}{\partial T} \right)_P = -\frac{\Delta H^{\ominus}}{T^2}$	$\frac{\Delta G^{\ominus}(T_2)}{T_2} - \frac{\Delta G^{\ominus}(T_1)}{T_1} = -\Delta H^{\ominus} \left(\frac{1}{T_2} - \frac{1}{T_1} \right)$	Allows for calculation of Gibbs energy at T ₂ given knowledge of Gibbs energy at T ₁ .

Partial derivatives to understand chemical systems

Chemistry often involves the use of functions of two variables or more. For example, the pressure of a gas is a function of temperature and volume, thus $P = P(T, V)$. If the temperature were to be held constant then P becomes a function of V only. Chemists represent that partial derivative with the following notation:

$$\left(\frac{\partial P}{\partial V} \right)_T$$

In chemistry the independent variable that is held constant in the differentiation (and in an experiment if there is a connection to experiment) is subscripted. If both the temperature and volume change, then the total change in pressure is the sum of the change due to the temperature and the change due to the volume as shown in the equation below. This equation is called a total differential.

$$dP = \left(\frac{\partial P}{\partial T} \right)_V dT + \left(\frac{\partial P}{\partial V} \right)_T dV$$

Partial derivatives are used ubiquitously in the energy and thermodynamics big idea and many of these relationships also appear in physics coursework. In chemistry the fundamental equations of thermodynamics as shown in Table 5 relate mechanical, fundamental, and composite properties. These equations are exact differentials and thus the cross derivatives are equal. These cross derivatives are known as the Maxwell relations.

To derive the Maxwell relations requires that a student have knowledge of differentials and partial derivatives. To understand their importance in chemistry (or physics) a student is required to blend his or her knowledge between mathematics and chemistry. In the laboratory it is possible to control T, P, and or V depending upon the experimental design. It is not possible to control entropy, S, through a device or instrument – there is no such thing as an entropy meter. The Maxwell relations related to the Helmholtz energy and Gibbs energy allow for a description of how a system's entropy varies with volume at constant temperature or how the system's entropy varies with pressure at constant temperature through measurements of P, T, and V. If one

can measure and describe how a system's pressure varies with temperature at constant volume, then one can make claims about how the system's entropy varies with volume at constant temperature. Similarly, if one can measure how volume varies with temperature at constant pressure, then claims about how the system's entropy varies with pressure at constant temperature can be made. Thus, the mathematics provides insight into chemical systems in ways that are not directly accessible through experiment.

Table 5: The fundamental equations of thermodynamics relating mechanical variables P and V, fundamental variables T, S, and U which are defined by the laws of thermodynamics, and composite variables H, A, and G. From these equations the Maxwell relations can be determined

Name (function)	Fundamental equations of thermodynamics	Maxwell relations
$U(S, V)$ = internal energy	$dU = T dS - P dV$	$\left(\frac{\partial T}{\partial V}\right)_S = -\left(\frac{\partial P}{\partial S}\right)_V$
$H(S, P)$ = enthalpy	$dH = T dS + V dP$	$\left(\frac{\partial T}{\partial P}\right)_S = \left(\frac{\partial V}{\partial S}\right)_P$
$A(T, V)$ = Helmholtz energy	$dA = -S dT - P dV$	$\left(\frac{\partial S}{\partial V}\right)_T = \left(\frac{\partial P}{\partial T}\right)_V$
$G(T, P)$ = Gibbs energy	$dG = -S dT + V dP$	$-\left(\frac{\partial S}{\partial P}\right)_T = \left(\frac{\partial V}{\partial T}\right)_P$

Infinitesimals

Recently at the 2023 RUME conference the Math-Science working group held a discussion of the use of calculus in the undergraduate curriculum, with a specific question about the role that limits and infinitesimals play and how they were used in the curriculum. Infinitesimals are used in the energy and thermodynamics big idea to describe pressure-volume work. They are useful in describing an idealized process known as a "reversible" process which leads to the maximum work being produced in an expansion. A reversible process is defined as a process which can be reversed thus restoring the system to the exact same state as before the process took place. Every step in the process is at equilibrium and the driving force is only the infinitesimally larger than the opposing force.

The example frequently given is the expansion (or compression) of an ideal gas in a frictionless piston where maximum work is calculated. Students often explore expansions which take place in fewer steps, such as one, two or three, then compare the work produced by the system in a reversible expansion as shown in Figure 2. For a reversible expansion the work produced is the area under the PV curve, thus students arrive at integration as the mathematical method to calculate the work. Stated differently, if the opposing pressure is constant as the volume is

increased infinitesimally, then the total work produced is the integral between the initial and final volume.

Reversible work for an expansion or compression of an ideal gas is:

$$w = - \int_{V_1}^{V_2} P_{opposing} dV = - \int_{V_1}^{V_2} \frac{nRT}{V} dV = -nRT \ln \frac{V_2}{V_1}$$

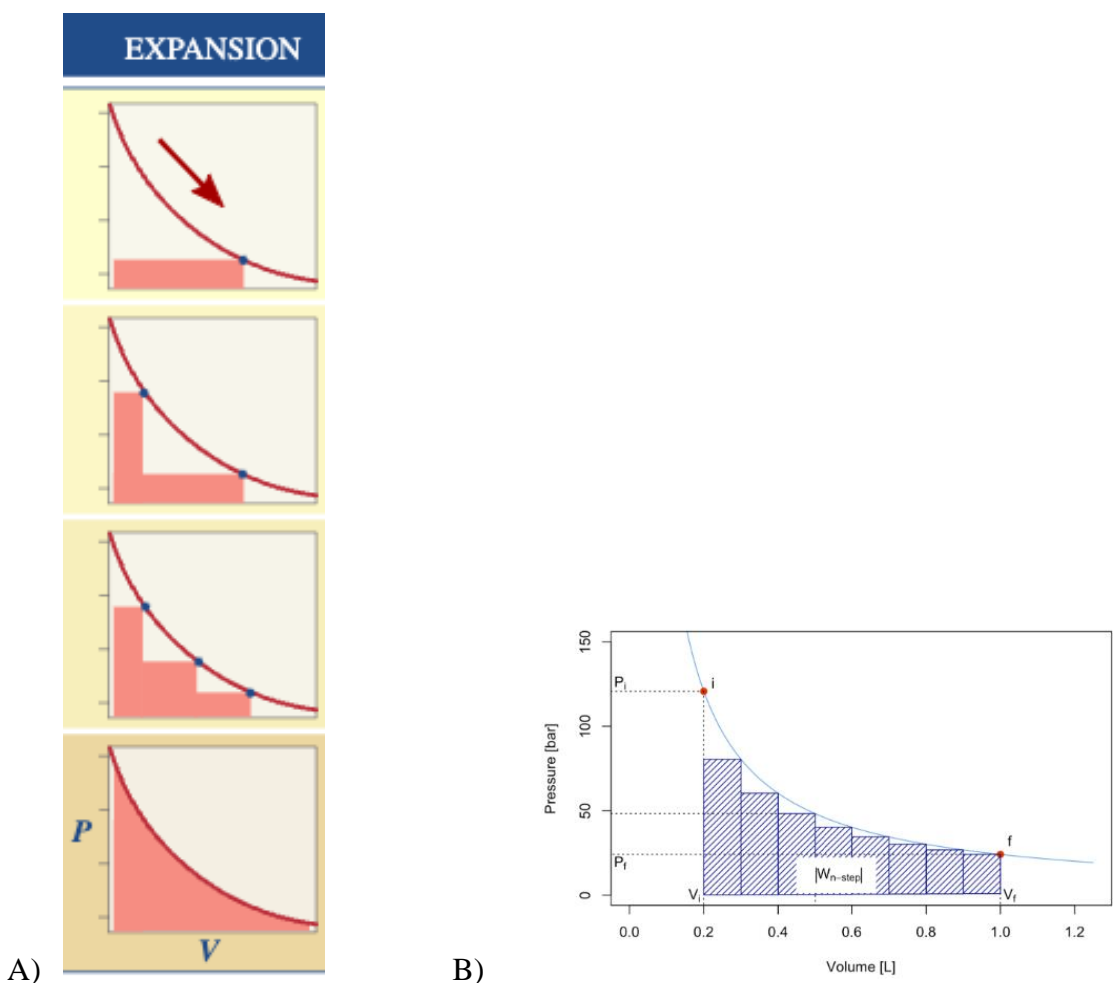

Figure 2: A) Work produced in orange from a single step, two step, three step, and reversible expansion (Lower, n.d.) B) Multi-step expansion demonstrating as the change in volume becomes infinitely small the representation approaches maximum work, the area under the curve (Perverati, n.d.)

Descriptions of bonds between atoms, molecular orbitals, and symmetry

In inorganic chemistry and physical chemistry bonding is explored through various models (Marek et al., 2018; Holme et al., 2018). Molecular orbital theory is introduced at a basic level (non-mathematical) to the students perhaps in general chemistry, but more often in inorganic

chemistry and physical chemistry. Molecular orbitals arise from linear combinations of atomic orbitals which are mathematical models. The calculus used involves integration and the results are often displayed as visually. Symmetry is also invoked as a condition for bonding as only orbitals of the correct symmetry may be used, and the results are represented visually. The diagram in Figure 3 shows an energy level diagram of the atomic orbitals on two hydrogen atoms (Halpern, n.d.). There are two molecular orbitals formed a bonding (lower energy) and anti-bonding (higher energy) molecular orbital. The symmetry aspects are encoded as “+” and “-“ symbols in the upper portion of Figure 3 and by two different colors in the anti-bonding σ_{1s}^* molecular orbital.

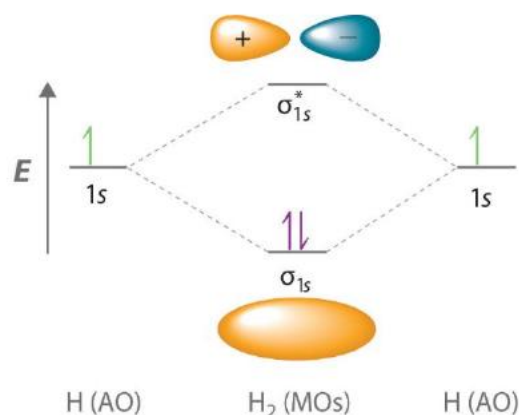

Figure 3: Molecular orbital energy- level diagram for H₂. The electrons in the 1s orbitals of each hydrogen atom fill the bonding 1s molecular orbital, denoted as σ_{1s} (Halpern, n.d.)

Experiments, discrete chunks, and variation

Laboratory coursework in physics, chemistry, biology, and engineering is a common feature of university programs. In these courses students spend (in the US) 1 to 3 hours in a laboratory classroom conducting experiments and analyzing data (although it is conceded that some of these experiments could be simulations completed on a computer). In a chemistry laboratory setting, students investigate the real world by collecting measurements and analyzing them. During the analysis they often make use of mathematical models which leverages a known relationship between quantities. Thus the theory, embodied in a mathematical relationship, matches the experiment. While the mathematical relationship is a function, which mathematicians may think of varying smoothly, students come to know this variation in a discrete or “chunky” manner, through the measurements obtained in the laboratory.

To give an example of a type of experiment, the data, and the reasoning, consider an experiment commonly carried out in a general chemistry course where the goals are to 1) construct a “calibration curve” by measuring the absorbance of a set of solutions of known concentration, and 2) use it to find the concentration of an unknown sample.

It is known that some substances absorb visible light in such a way that they obey Beer's Law where the absorbance of light is related to the concentration of the solution. The equation for Beer's Law shown below.

$$A = \epsilon c$$

A = Absorbance

ϵ = molar absorptivity, a constant

ℓ = optical path length

c = concentration of species interacting with (attenuating) the light

In the laboratory the students use an instrument called a UV-Vis spectrophotometer to measure the absorbance of a set of solutions. In the experiment the students would be tasked with creating 5 samples of decreasing concentration by serial dilution. The experiment then involves measuring the absorbance at one specific wavelength in the visible region of the electromagnetic spectrum where the material exhibits the strongest absorbance. The usual method is to measure the absorbance of the "blank", a solution with none of the absorbing substance in it, then the measure the other solutions which contain a known amount of the absorbing material.

For this experiment, the solutions that the students made are shown in Figure 4 and are solutions 2-6. Solution 1 contains only water (the solvent) and none of the absorbing material. The absorbance and concentration data for each solution is shown in Table 6 and the graph of the data with the corresponding solution is shown in Figure 4 (Harvey, n.d.).

Table 6: Sample student data for absorbance experiment. The concentration values are calculated via a serial dilution. The absorbance values are readings from the spectrophotometer

Concentration (M)	Absorbance
0	0
0.0015	0.045
0.0031	0.093
0.0047	0.142
0.0064	0.192
0.0079	0.240

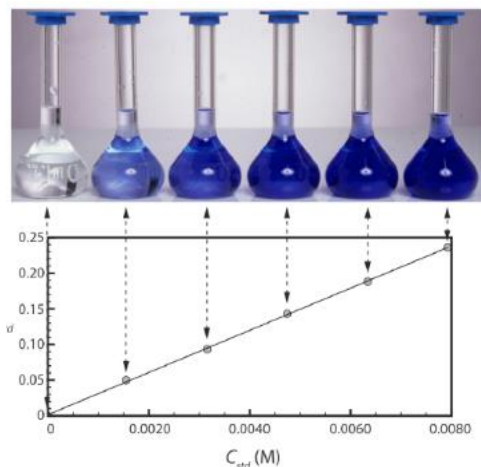

Figure 4: The blank and five sample solutions aligned with their data points on a graph generated from the data in Table 6 (Harvey, n.d.)

The graph in Figure 4 and an associated trendline ($y = 29.368x + 0.0012$) could be used to determine the concentration of an unknown. For example, imagine that this blue color comes from a dye called Blue 1, which can be used to make beverage drinks (it is in a product called Kool-Aid in the US). Given a sample of blue or purple Kool-Aid, one could measure the absorbance of the sample and determine the concentration of the Blue 1 dye in the Kool-Aid sample.

The point of this example and its connection to the conference is to highlight that mathematicians and scientists may view variation, or covariation, differently. There are thousands of papers and book chapters pertaining to covariation, but here two will be highlighted as perhaps being useful to inspire conversations at the conference.

In “Chunky and smooth images of change” by Castillo-Garsow, Johnson, and Moore (2013), they note that research on variation suggests “how students conceptualize variation influences the mathematics that they construct.” Based upon their research the authors note that in the chunky version of change discrete points exist which produces chunky conceptualizations of variation, and this is a less powerful conceptualization than a smooth image of change.

Thompson and Carlson (2017) explore covariation as a foundational principle in mathematics. In this chapter, they proposed a revised covariational reasoning framework as a lens for future research (see Table 13.3) and a table that describes that describes their current view, in 2017, of the major levels of covariational reasoning (see Table 13.4). Both tables serve as a lens through which mathematicians consider the conceptualization of covariation.

The research focusing on covariational reasoning supports the conclusion that mathematicians favor smooth conceptions of covariation and variation over chunky. The desire is for students to build conceptions that lead to smooth continuous variation and thus can be linked to a conceptualization of functions. This is problematic for undergraduate students in the sciences and engineering where data is acquired in a discrete, chunky fashion (Dray et al., 2019). Every experiment has a context and the measurements obtained are attributes of the system under investigation and very often these measurements have units.

It is seldom the case that chemistry instructors describe measurements in laboratory as a set of values from independent and dependent variables that are changing smoothly. One may ask why and one simple answer is that often the goal is to measure and or identify a specific value that physically describes the chemical system (the concentration of the unknown or the order of a chemical reaction). Additionally, the independent variables are often values of physical attributes of the sample which are known, such as a concentration. Smooth variation of the variables is not part of the roots or foundational of understanding the chemical system that is under investigation.

Thus, beyond the exploration of where and how calculus is used in undergraduate chemistry, perhaps at this conference there may be room for conversations about the nature of experiments in the sciences and engineering and the kind of covariational thinking it supports (more chunky) and the smooth thinking favored by mathematicians.

References

- 2023 ACS Guidelines for Undergraduate Chemistry Programs: Approved. (n.d.)
<https://drive.google.com/file/d/1xy8PWWCsrK4ZOUsc9bE6iq9hWS1I5Y1E/view>
- Alberty, R. A. (1994). Farrington Daniels. In *Biographical Memoirs* V. 65. (pp.107-121) The National Academies Press. <https://doi.org/10.17226/4548>
- American Chemical Society. (n.d.) *Areas of Chemistry*. <https://www.acs.org/careers/chemical-sciences/areas.html>
- American Chemical Society SOCED Report. (2005). *Exploring the Molecular Vision*. http://208.77.250.174/portal/PublicWebSite/about/governance/committees/education/WPCP_010714
- Billings, E. (1950). *Summary history of the American Chemical Society Committee on Professional Training covering period 1936-1949 inclusive*. Report to the American Chemical Society.
- Castillo-Garsow, C.; Johnson, H.; Moore, K. C. (2013). Chunky and Smooth images of change. *For the Learning of Mathematics*, 33(3), 31-37.
- Daniels, F. (1928). *Mathematical Preparation for Physical Chemistry*. McGraw-Hill.
- Daniels, F. (1929). Mathematical requirements for physical chemistry. *J. Chem. Educ.*, 6(2), 254-258.
- Daniels, F. (1931). Introduction to the symposium on “Mathematics in the service of Chemistry. *J. Chem. Educ.*, 8(6), 1060-1061.
- Daniels, F. (1958). Teaching physical chemistry – forty years of change. *J. Chem. Educ.* 35(7), 322-323.
- Dray, T., Gire, E., Kustusich, M. B., Manogue, C. A., & Roundy, D. (2019). Interpreting Derivatives. *PRIMUS*, 29(8), 830-850.
- Halpern, J. (n.d.). *11.5 Molecular Orbital Theory*. Libre Texts Chemistry. (see Figure 11.5.2).
https://chem.libretexts.org/Bookshelves/General_Chemistry/Map%3AGeneral_Chemistry%28Petrucci_et_al.%29/11%3A_Chemical_Bonding_II%3A_Additional_Aspects/11.5%3A_Molecular_Orbital_Theory

- Harvey, D. (n.d.). 5.3: *Determining the sensitivity*. Libre Texts Chemistry. (see Figure 5.3.2).
https://chem.libretexts.org/Courses/BethuneCookman_University/B-CU%3A_CH-345_Quantitative_Analysis/Book%3A_Analytical_Chemistry_2.1_%28Harvey%29/05%3A_Standardizing_Analytical_Methods/5.03%3A_Determining_the_Sensitivity
- Holme, T., & Murphy, K. (2012). The ACS Exams Institute Undergraduate Chemistry Anchoring Concepts Content Map I: General Chemistry. *J. Chem. Educ.*, 89(6), 721– 723, DOI: 10.1021/ed300050q
- Holme, T., Luxford, C., & Murphy, K. (2015). Updating the General Chemistry Anchoring Concepts Content Map. *J. Chem. Educ.*, 92(6), 1115– 1116, DOI: 10.1021/ed500712k
- Holme, T. A., Reed, J. J., Raker, J. R., & Murphy, K. L. (2018). The ACS Exams Institute Undergraduate Chemistry Anchoring Concepts Content Map IV: Physical Chemistry. *J. Chem. Educ.*, 95(2), 238– 241, DOI: 10.1021/acs.jchemed.7b00531
- Holme, T. A., MacKellar, J., Constable, D. J. C., Michels, O., Trate, J. M., Reed, J. J., Raker, J. R., & Murphy, K. L. (2020a). Adapting the Anchoring Concepts Content Map (ACCM) of ACS Exams by Incorporating a Theme: Merging Green Chemistry and Organic Chemistry. *J. Chem. Educ.*, 97(2), 374– 382.
- Holme, T. A., Bauer, C., Trate, J. M., Reed, J. J., Raker, J. R., & Murphy, K. L. (2020b). The American Chemical Society Exams Institute Undergraduate Chemistry Anchoring Concepts Content Map V: Analytical Chemistry. *J. Chem. Educ.*, 97(6), 1530– 1535.
- Lower, S. (n.d.). 14.2 *The First Law of Thermodynamics*. Libre Texts Chemistry. (see Figure 14.2.1.)
https://chem.libretexts.org/Bookshelves/General_Chemistry/Chem1_%28Lower%29/14%3A_Thermochemistry/14.02%3A_The_First_Law_of_Thermodynamics
- Marek, K. A., Raker, J. R., Holme, T. A., & Murphy, K. L. (2018). The ACS Exams Institute Undergraduate Chemistry Anchoring Concepts Content Map III: Inorganic Chemistry. *J. Chem. Educ.*, 95(2), 233– 237, DOI: 10.1021/acs.jchemed.7b00498
- Murphy, K. L., Holme, T. A., Zenisky, A., Caruthers, H., & Knauss, K. (2012). Building the ACS Exams Anchoring Concepts Content Map. *J. Chem. Educ.*, 89(6), 715-720.
- Peverati, R. (n.d.). 2.4 *Calculation of work*. Libre Texts Chemistry.
[https://chem.libretexts.org/Bookshelves/Physical_and_Theoretical_Chemistry_Textbook_Maps/The_Live_Textbook_of_Physical_Chemistry_\(Peverati\)/02%3A_Zeroth_Law_of_Thermodynamics/2.04%3A_Calculation_of_Work](https://chem.libretexts.org/Bookshelves/Physical_and_Theoretical_Chemistry_Textbook_Maps/The_Live_Textbook_of_Physical_Chemistry_(Peverati)/02%3A_Zeroth_Law_of_Thermodynamics/2.04%3A_Calculation_of_Work)
- Raker, J., Holme, T., Murphy, K. (2013). The ACS Exams Institute Undergraduate Chemistry Anchoring Concepts Content Map II: Organic Chemistry. *J. Chem. Educ.*, 90(11), 1443– 1445, DOI: 10.1021/ed400175w
- Servos, J. W. (1986) Mathematics and the physical sciences in America, 1880-1930. *Isis*, 77(4), 611-629.
- Shapley, P. (2011). *Chemistry the Central Science*. Introduction to Chemistry 102.
<http://butane.chem.uiuc.edu/pshapley/genchem1/intro/>
- The Nobel Prize in Chemistry 1914*. (n.d.) The Nobel Prize.
<https://www.nobelprize.org/prizes/chemistry/1914/summary/>

Thompson, P. W.; Carlson, M. P. Variation, Covariation, and Functions: Foundational Ways of Thinking Mathematically. In *Compendium for research in Mathematics Education*. In J. Cai, Ed.; National Council of Mathematics Teachers: Reston, VA, 2017, pp. 421-456.

Calculus in mathematics for economists (ver. 3.2 / May 10, 2023)

Rainer Voßkamp¹

¹University of Kassel, Germany; vosskamp@uni-kassel.de

Abstract. The teaching of mathematics for economics (ME) differs significantly from the teaching of mathematics in mathematics study programs, especially in the area of calculus. The reasons for this I will discuss first. By means of examples, I will work out by which features ME can be characterized. Among the features are the emphasis on mathematical modeling, the intensive use of simplifications, heuristics and applications. Finally, I will formulate theses on the opportunities and risks of using these features of ME. This can serve as a basis for further discussions among teachers and researchers from economics, mathematics and didactics.

Note. This is a short version of a working paper (Voßkamp, 2023a), which is available here (soon): <https://www.uni-kassel.de/go/vosskamp>. The numbering of models, definitions etc. in this short version of the paper corresponds to the numbering in the working paper (Voßkamp, 2023a).

Prologue

Mathematical methods have played an important role in economic research for about 70 years. The beginning of the mathematization of economics can be marked with the fundamental work of - amongst others - P. A. Samuelson, K. Arrow and G. Debreu and in the 1940s and 1950s (e.g. Samuelson, 1947; Arrow & Debreu, 1954; Hodgson, 2012). In particular, the increasing importance of empirical approaches and analysis due to the availability of data, hardware and software also increases the importance of mathematics (including statistics) in economics (cf. Stigler et al. 1995). These developments are also evident in the field of business administration. Since mathematics in economics is more important than in business administration, this article will mainly focus on mathematics for economists.

Mathematics is not only taught in mathematics programs (bachelor, master, teacher-training programs). Mathematics and thus mathematics modules are present in many study programs, including programs in business administration and economics. The amount of mathematics provided in business administration and economics programs is considerable (cf. e.g. Voßkamp, 2017; Allgood et al., 2015). However, there has been limited educational research on mathematics in economics and business administration. Moreover, teachers of mathematics for economics are only minimally concerned with higher education didactic concepts of mathematics. The reasons here are manifold.

The focus of this paper is on the important topic of differential and integral calculus in the context of economics (calculus in economics; CE), although this field cannot be separated from analysis in economics (AE) and from mathematics for economics (ME). This article clarifies important framework conditions, which significantly influence ME and make clear that core mathematics differs from ME. To this end, I will use examples to highlight some important features that characterize ME. However, it is problematic that ME cannot be clearly defined or demarcated because there are different views on the part of economists (and thus also of teachers of ME).

The structure of the article is as follows: After the introduction, some remarks on the background of ME follow - including a brief overview on the topics of ME, AE and CE. Afterwards I will deal with some important features of ME. Examples from ME are used to illustrate the main features. A short epilogue concludes the article.

Background

Business administration and economics

Two scientific disciplines deal with economic phenomena. Business administration focuses on single firms, while economics looks at (a part of) a whole economy. In the English-speaking world, this distinction is often dispensed with, so that one simply speaks of economics. This preliminary remark is important because, in these two disciplines, the role of mathematics is very different. In economics there are much more quantitative and qualitative approaches with mathematical methods than in business administration.

Fundamental problems

Teaching ME differs significantly from teaching mathematics in core mathematics programs (bachelor and master programs, teacher-training programs). Many first-year students are surprised at the beginning of their studies that mathematics modules are compulsory in the context of business administration and economics study programs. This relates to the fact that students' intrinsic motivation is often weak, which is especially evident for students in business administration study programs.

In addition, fundamental problems, among others, include the following:

1. Students' transition from school to university is often problematic (cf. e.g. Laging & Voßkamp, 2017; Büchele & Feudel; 2023).
2. First-year students show insufficient competencies in secondary mathematics (cf. e.g. Laging, Voßkamp, 2017; Büchele & Feudel; 2023).
3. The consequences of the Corona Pandemic are dramatic (cf. e.g. Büchele et al., 2021).

As a rule, extensive support services (e.g., pre-courses, bridging courses, open learning spaces) are provided in the introductory phase of studies. However, in many cases these are only used to a limited extent (cf. e.g. Laging & Voßkamp, 2016; Büchele et al., 2022). In addition, the mathematics modules have only a small weight in determining the overall grade. Therefore, many students only aim to achieve a grade 4, which in Germany typically implies only just passing an exam. Finally, the use of mathematical methods in economics is viewed critically by a small minority (cf. e.g. Gräbner & Strunk, 2020). These positions are often used by students to fundamentally question the importance of mathematics in economics programs.

Mathematics vs calculus

While mathematics courses (bachelor and master programs, teacher-training programs) include several modules in analysis / calculus along with many other modules, students of economics usually have to take only a few compulsory modules (one to three) in ME (cf. Voßkamp, 2017).

Within the framework of these modules, topics from analysis (limits of sequences and functions, continuity, differential calculus and integral calculus) are of great importance. In addition, topics from linear algebra and other sub-disciplines of mathematics are usually covered. Thus, analysis - and therefore calculus - is taught in a close context with other mathematical sub-disciplines.

Teaching ME

The design of a module within a degree program depends on given structures (e.g. examination regulations). However, the design of a module also largely depends on (amongst others) the qualifications, the affiliation, the professional status and the responsibilities of teachers. (cf. Voßkamp, 2017).

Content

The following list of topics is an example for a module ME. This is (more or less) the structure of the lecture ME, which I offer at the University of Kassel:

1. Basics: Logic, modeling, sets, Cartesian products, relations, functions
2. Analysis I: Sequences, series, financial mathematics, functions, differential calculus ($n = 1$)
3. Analysis II: Functions, differential calculus (incl. constrained optimization) ($n > 1$)
4. Analysis III: Integration ($n = 1, n > 1$), difference and differential equations
5. Linear Algebra

In the context of ME the topics of analysis play an important role, which are also fundamental in (core) analysis courses on functions with one variable (case $n = 1$) or on functions with several variables (case $n > 1$): Limits (sequences, functions), continuous functions, differentiable functions, integrals.

Since functions with several variables already play an important role in the basic economics modules of the first semester (especially in the module microeconomics), analysis for functions with several variables is of great importance in the context of ME, which is taught in the first semester.

In detail, however, there are topics which - relative to (core) calculus - have a lesser or greater importance in CE. In the case $n = 1$ from an economics perspective, the following topics are important among others: Differentials, growth rates, elasticities. In the case $n > 1$, partial and total differentials, partial elasticities, constrained optimization (in particular: Lagrange method). The selection is driven by the economic applications.

Features

Due to the heterogeneity of the teachers, the modules ME are also very heterogeneous. This can also be seen from the fact that there are probably more than 200 textbooks on ME in the German language area available (cf. Voßkamp, 2023b). Even if one considers only the textbooks that are used often in German-speaking countries (among others Sydsaeter et al., 2021; Chiang & Wrainwright, 2005; Merz & Wüthrich, 2011; Simon & Blume, 1994) the textbooks are very heterogeneous in several respects. Nevertheless, some features can be mentioned which are - more

or less - characteristic for ME. In the following, I will address some features, where strong differences between core calculus and CE are present. The list of features is, however, quite subjective.

Modelling

Every science is about gaining new knowledge. Thus, it is about clarifying the truth of statements. This is no different in economics. However, economic phenomena and thus economic questions are usually complex and complicated, so that the extraction of knowledge is also usually difficult. Against this background, mathematical modeling has a very high value in economics. Starting point for building an economic model is an economic question. We understand a model as a set of assumptions (definitions and hypotheses). Based on the assumptions, theorems can be formulated which have to be proved. Thus, mathematical logic and mathematical modeling are closely connected. The triad of mathematics definition-theorem-proof "mutates" to model-theorem-proof. For illustration, I will present a first example drawn from macroeconomics.

The starting point is the following statement S , which economist and politicians use very often in discussions of economic policy:

$S =$ "If private investment increases, then gross domestic product (GDP) increases."

The goal is to prove the truth of statement S . Therefore, I use a simple multiplier model (cf. Blanchard, 2020).

Model 1: Multiplier model

A.1 Consider an economy in which only private firms and private households are economically active. The state is not taken into account. Furthermore, there are no relations to other economies.

A.2 The following variables are defined:

Y gross domestic product

C household consumption

I investment of private firms

All variables are to be measured in monetary units (e.g., euros). The values refer to a period (e.g. a calendar year). In addition, the following should apply: $Y, C, I \in \mathbb{R}_0^+$

A.3 Let the gross domestic product Y equal the sum of household consumption C and investment I :

$$Y = C + I$$

A.4 Household consumption C depends linearly on gross domestic product Y :

$$C = \bar{C} + cY$$

where $\bar{C} > 0$ and $0 < c < 1$.

A.5 Let private investment I be given by the constant value \bar{I} with $\bar{I} > 0$:

$$I = \bar{I}$$

The mathematical model is given by:

- three equations: $Y = C + I$, $C = \bar{C} + cY$, $I = \bar{I}$
- three variables: Y , C , I
- three parameters: $0 < c < 1$, $\bar{C} > 0$, $\bar{I} > 0$

True statements can be derived from the assumptions of the model. Two examples:

Theorem 1

Under assumptions A.1 to A.5,

$$Y = \frac{1}{1-c}(\bar{C} + \bar{I})$$

Theorem 2

Under assumptions A.1 to A.5, if private investment increases by 1 unit, GDP increases by $1/(1-c)$ units.

The theorems must then be proved:

Proof 1

We substitute the equations $C = \bar{C} + cY$ and $I = \bar{I}$ into the equation $Y = C + I$ and after equivalent transformations we obtain:

$$\begin{aligned} Y &= C + I \\ \Leftrightarrow Y &= \bar{C} + cY + \bar{I} \\ \Leftrightarrow Y - cY &= \bar{C} + \bar{I} \\ \Leftrightarrow (1-c)Y &= \bar{C} + \bar{I} \\ \Leftrightarrow Y &= \frac{1}{1-c}(\bar{C} + \bar{I}) \quad \text{q.e.d.} \end{aligned}$$

The proof of the second theorem follows directly from the first: since $0 < c < 1$ holds, the factor $1/(1-c)$ is positive (and also greater than 1).

Therefore, based on the model, statement S is true. However, a critical analysis of the result must take place. On the one hand, the model (and thus the model assumptions) has to be critically examined. On the other hand, based on data and the use of econometric (and other) methods, the results of the model must be tested. Here, good reasons exist to use sophisticated models to clarify the issue (cf., e.g., Blanchard, 2020).

Simplifications

In ME, simplifications are often used. There are two reasons for this:

1. Within the framework of a module ME, calculus cannot be treated in full breadth and depth. To avoid facts becoming too complicated and / or too complex, assumptions are often made within the framework of ME that lead to simplifications.
2. However, simplifications are often reasonable and understandable for economic reasons.

Simplifications are regularly made in AE, for example, only continuous functions are considered, so there for instance no difference between Riemann and Leibniz integrals. Simplifications are fundamentally problematic because they prevent statements that are more general. If simplified assumptions are made, this must be disclosed and discussed.

Heuristics

Heuristics are to be distinguished from simplifications. A heuristic is a method to get valuable results quickly (cf. Gigerenzer et al., 2011). The problem of a heuristic is that it does not always lead to perfect results. Heuristics can take the form of definitions, theorems, and proofs. Example:

Heuristic definition 3: Derivative at x_0

A function $f : D \rightarrow \mathbb{R}$ is differentiable at x_0 if a tangent line with tangent point $(x_0, f(x_0))$ can be placed on the graph of the function.

Heuristic definition 4: Derivative of f

A continuous function $f : D \rightarrow \mathbb{R}$ is differentiable if the graph of the function has no vertices.

Definition 2: Derivative at x_0 / derivative of f

Let $f : D \rightarrow \mathbb{R}$ and $D \subseteq \mathbb{R}$ with $x_0 \in D$. If the limit exists

$$\lim_{\delta x \rightarrow 0} \frac{f(x_0 + \delta x) - f(x_0)}{\delta x}$$

then f is called differentiable at the point x_0 . If f is differentiable in all points $x_0 \in D$, then f is called differentiable.

This example makes clear which problems can arise when using a heuristic definition. For example, the Heuristic definition 3 is problematic for $x_0 = 0$ in the case of the functions $f(x) = \sqrt{x}$ and $f(x) = x^3$. Heuristic definition 4 uses the term "vertices" which is not defined. Moreover, in the first case we look at the point x_0 . In the second case, the focus is on the derivative as a whole. However, the heuristic definitions could be modified to capture both, the derivative at x_0 and the derivative function.

In general, for didactic reasons, the exact version should always be given as well, even if it is not used further in the framework. The comparison makes clear that there are obviously cases where the heuristic version cannot be applied.

Applications / examples

In ME / AE / CE, economic examples are used intensively and these are often simple applications from microeconomics and macroeconomics. Two reasons play a role:

1. Economic examples are often used to motivate methods in ME / AE / CE.
2. Economic examples are also used to illustrate the advantageousness of mathematical methods and the mathematical in answering economic questions.

In the next section this is illustrated by several examples.

Diagrams / graphical representations

In ME / AE / CE, we work intensively with diagrams. The background is that both in economic textbooks as well as in economic research papers, diagrams are used intensively. Very often it is about the representation in R^2 of the graphs of (two) functions of a variable. The most important example is probably the price-quantity diagram, in which the inverse demand curve $p = p(x; a_1, \dots, a_m)$ and the inverse supply function $p = p(x; b_1, \dots, b_n)$ are represented (see Figure 1). p is used for price, x for quantity. $a_1, \dots, a_m, b_1, \dots, b_n$ represent location parameters which we will disregard in the following.

A simple demand function $x = x(p)$ establishes a relationship between demand x and p . In most cases, the higher the price p , the lower the demand x . A simple supply function $x = x(p)$ establishes a relationship between supply x and p . In most cases, the higher the price p , the higher the supply x . Thus, strictly monotone functions are assumed so that inverse functions exist.

A side note: We have used only the variables x and p here for good reasons. If a very exact notation is chosen, we write (with d for demand and s for supply): $p^d = p^d(x^d)$ and $p^s = p^s(x^s)$.

For the price-quantity diagram (see Figure 1), there are no problems, because quantities are plotted on the abscissa and prices on the ordinate. Moreover, the focus is on market equilibria (x^*, p^*) . In a market equilibrium (x^*, p^*) we have $x^d = x^s$ and $p^d = p^s$

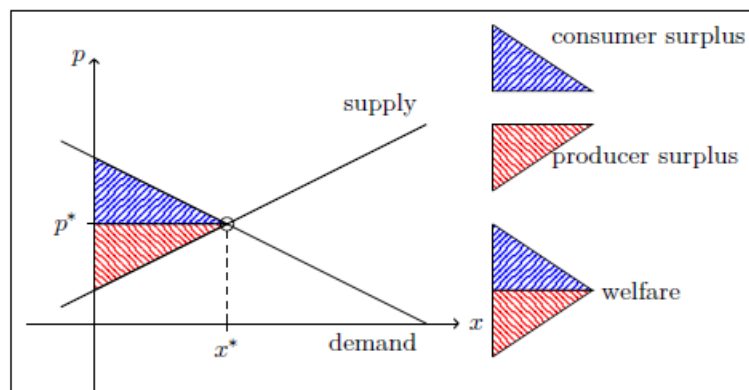

Figure 1: Demand, supply, consumer and producer surplus, welfare

In this example, the slopes of the functions play an important role. In addition, important quantities such as consumer surplus, producer surplus and welfare can be represented by surface areas and

thus by definite integrals. Models with more than two endogenous variables are also often represented with diagrams. For this purpose, so-called reduced models are considered, which then contain only two (independent) variables (in addition to parameters). Examples: IS-LM model, AD-AS model (cf. Blanchard, 2021).

Measurement

For the understanding of economic matters, it is (similar to physics) very often helpful to specify the units in which variables are measured. This is especially true in the context of marginal variables that arise by differentiation.

As an example, the concept of marginal cost will be discussed (cf. Feudel, 2020; Feudel & Biehler, 2022). Assume that there is a functional relationship between cost C and the quantity x produced. Cost C is measured in monetary units [\$], the quantity produced x in units of quantity [pieces].

Consequently, marginal cost $C'(x) = dC / dx$ is measured in monetary units per unit of quantity: [\$/[pieces]. For details, consider the difference quotient or differential quotient:

$$\frac{\Delta C}{\Delta x} = \frac{C(x + \Delta x) - C(x)}{\Delta x} \quad \frac{[\$] - [\$]}{[\text{pieces}]}$$

$$\frac{dC}{dx} = \lim_{\Delta x \rightarrow 0} \frac{C(x + \Delta x) - C(x)}{\delta x} \quad \frac{[\$] - [\$]}{[\text{pieces}]}$$

Marginal cost is often defined as the cost of an additional marginal unit of quantity produced. This formulation suggests that marginal cost is measured in monetary units [\$]. However, this is incorrect. Marginal costs ultimately indicate the average cost of an additional (marginal) unit of quantity. They are measured as in monetary units per unit of quantity: [\$/[pieces]. This information is also important, for example, for understanding elasticities and growth rates.

Examples: Some lessons from micro- and macroeconomics

In this section, I will present four examples from CE that (usually) show some of the features presented in the previous section. In the long version of this paper, I present two further examples on constrained optimization and approximation (Voßkamp, 2023a).

Elasticities: What is the impact of price on demand for a good?

Economists usually assume that there is a functional relationship between the demand x for a good (e.g. milk or cars) and the corresponding price p (see previous subsection on diagrams / graphical representations). It is usually assumed that the corresponding demand function $x = x(p)$ is differentiable any number of times. Popular demand functions are linear and iso-elastic demand functions:

Definition 3: Demand functions

A linear demand function is given by (with $x \geq 0$):

$$x(p) = a - bp$$

An iso-elastic demand function is given by (with $x > 0$):

$$x(p) = \alpha p^{-\beta}$$

a and b as well as α and β are positive real-valued parameters.

Using the derivative $dx/dp = x'(p)$, we can determine the influence of the price p on the demand x (see Figure 2).

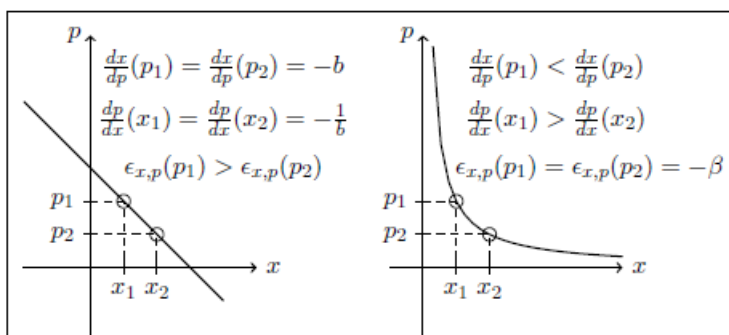

Figure 2: Inverse demand functions

While x is measured in [pieces] and p in [\$/pieces] we have:

$$dx/dp \quad \frac{[\text{pieces}]}{[\$/\text{pieces}]} = \frac{[\text{pieces}]^2}{[\$]}$$

For the two examples, we obtain:

$$\frac{dx}{dp} = -b \quad \frac{dx}{dp} = \alpha\beta p^{-\beta-1}$$

Thus, it is possible to calculate what change in demand can be expected if the price changes marginally. Approximately, a marginal price change might be 1 \$. The change in quantity is calculated by

$$dx = x'(p) \cdot 1$$

$$[\text{pieces}] = \frac{[\text{pieces}]^2}{[\$]} \cdot \frac{\$}{[\text{pieces}]}$$

However, this information is of very limited use when comparing quantity responses for different goods that have very different prices. In the case of milk, a 1 \$ change in price will be dramatic; in the case of automobiles, it will not be noticeable. Therefore, in economic applications, elasticities are often considered, which put relative changes into perspective. In the concrete (initially discrete)

case, it is asked what relative change in demand $\Delta x/x$ results when a relative price change $\Delta p/p$ occurs. It is then calculated:

$$\left(\frac{\Delta x}{x}\right) \bigg/ \left(\frac{\Delta p}{p}\right) = \left(\frac{\Delta x}{\Delta p}\right) \bigg/ \left(\frac{x}{p}\right)$$

For marginal price changes, we then define:

Definition 4: Price elasticity

Assume a differentiable demand function $x = x(p)$ and $x \neq 0$ and $p \neq 0$. Then

$$\varepsilon_{x;p}(p) = \lim_{\Delta p \rightarrow 0} \left(\frac{\Delta x}{x}\right) \bigg/ \left(\frac{\Delta p}{p}\right) = \lim_{\Delta p \rightarrow 0} \left(\frac{\Delta x}{\Delta p}\right) \bigg/ \left(\frac{x}{p}\right) = \left(\frac{dx}{dp}\right) \bigg/ \left(\frac{x}{p}\right)$$

is called the price elasticity of demand.

Obviously, price elasticities are dimensionless.

Elasticities and especially price elasticities are often used in economics because of the ease in which they can be interpreted. It holds (approximately): The price elasticity $\varepsilon_{x;p}(p)$ indicates the percentage change in demand when the price changes by 1 %. For example, if $\varepsilon_{x;p}(p) = -2$, then demand is reduced by approximately 2 % when the price increases by 1 %:

$$-2 = \varepsilon_{x;p}(p) \approx \frac{\Delta x/x}{\Delta p/p} = \frac{-2\%}{1\%} = -2$$

Theorem 4

For linear demand functions, non-constant price elasticities result:

$$\varepsilon_{x;p}(p) = -\frac{bp}{a - bp}$$

For iso-elastic demand functions, constant price elasticities result:

$$\varepsilon_{x;p}(p) = -\beta = \text{const.}$$

Price elasticities are often estimated based on iso-elastic demand functions using regression models.

$$\ln(x_i) = \ln(\alpha) + \beta \ln(p_i) + e_i$$

Then, β equals $\varepsilon_{x;p}(p)$. In Table 1, some price elasticities are presented.

Table 1: Estimates of price elasticities (cf. Wilkinson (2005))

product	$\varepsilon_{x;p}$
bread	-0.09
milk	-0.18/ - 0.49
tobacco products	-0.46
potatoes	-0.27
beef	-0,65
beer	-0.84
restaurant meals	-1.63

In general, elasticities are defined as follows:

Definition 5: Elasticity

Assume a differentiable function $y = f(x)$ and $y \neq 0$ and $x \neq 0$. Then

$$\varepsilon_{y;x}(x) = \left(\frac{dy}{dx} \right) / \left(\frac{y}{x} \right)$$

is called the x -elasticity of y .

Differential calculus: What is the impact of a monopolist's price setting behavior on profit?

If this question is asked, many answer ad hoc that a monopolist's profit will increase if the price for the good increases. However, this is only true under certain conditions. With the help of a simple model, the relationships can be examined. We use the following assumptions:

Model 2: Monopoly

A.1 The demand for the good is given by the following inverse demand function (with $a, b \in \mathbb{R}^+$):

$$p(x) = a - bx$$

A.2 The cost of production is given by the following cost function (with $c \in \mathbb{R}^+$):

$$C(x) = cx$$

A.3 The firm maximizes profit.

The monopolist's profit $\Pi(x)$ is given by revenues $R(x)$ minus cost $C(x)$:

$$\Pi(x) = R(x) - C(x) = p(x)x - C(x) = ax - bx^2 - cx$$

Using the known necessary and sufficient conditions for a maximum, we obtain the profit-maximum quantity

$$x^M = \frac{a - c}{2b}$$

To this profit-maximum quantity x^M belongs the profit-maximum price

$$p^M = \frac{a + c}{2}$$

Thus, it follows:

Theorem 5: Pricing in a monopoly

1. If the current price p_0 is less than the profit-maximal price p^M , an increase of the price leads to an increase of the profit as long as $p \leq p^M$ holds.
2. But: if $p_0 > p^M$ holds, an increase in price will lead to a reduction in profit.

Figure 3 represents the relationships in a graph.

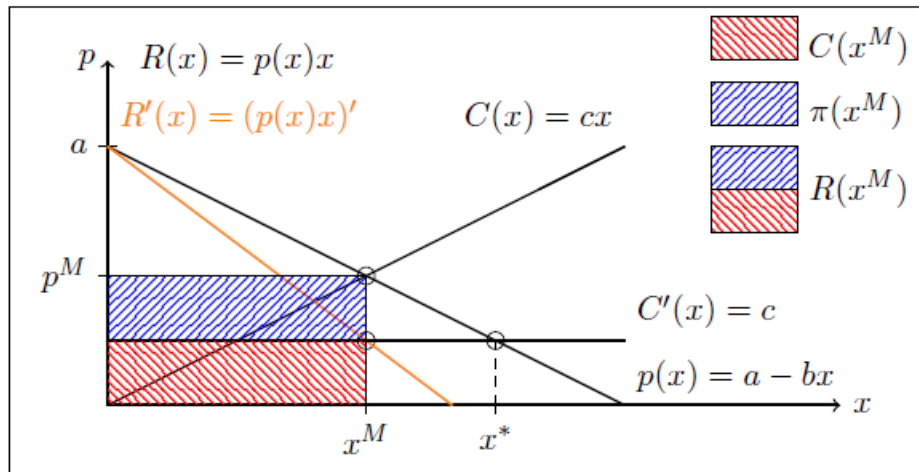

Figure 3: Pricing in a monopoly

Moreover, $x^M < x^*$ and $p^M > p^*$ holds. This result shows arguments why a monopoly is - economically speaking - disadvantageous.

Integral calculus: When is an exhaustible resource exhausted?

This question can be answered again based on a simple model.

Model 6: Exhaustible resources

- A.1 We consider a resource (e.g. crude oil) whose stock at time $t = 0$ is given by $B_0 > 0$.
- A.2 We assume that the resource is consumed at a constant rate r . Let the consumption $R(t)$ at time $t = 0$ be $R(0) = R_0$.

Intuitively, it is usually expected that under these assumptions the resource will be exhausted, even if the rate r is negative and thus consumption decreases. Nevertheless, is this conjecture correct?

Assumption A.2 implies the following differential equation: $r = R'(t)/R(t)$ The special solution leads to the following resource consumption function:

$$R(t) = R_0 e^{rt}$$

The consumption up to a point of time T is (assuming $r \neq 0$):

$$S(T) = \int_0^T R(t) dt = \left[\frac{R_0}{r} e^{rt} \right]_0^T = \frac{R_0}{r} (e^{rT} - 1)$$

In case $r = 0$, the resource consumption is constant R_0 :

$$R(t) = R_0 e^{0t} = R_0$$

Up to point of time T , the resource consumption is $S(T)$:

$$S(T) = \int_0^T R_0 dt = [R_0 t]_0^T = R_0 T$$

T , the point of time at which the resource is exhausted, can be determined by solving the equation

$$S(T) = B_0$$

It follows ($r \neq 0$):

$$\begin{aligned} B_0 &= \frac{R_0}{r} (e^{rT} - 1) \\ \Leftrightarrow \frac{rB_0}{R_0} &= e^{rT} - 1 \\ \Leftrightarrow \frac{rB_0}{R_0} + 1 &= e^{rT} \\ \Leftrightarrow \ln \left(\frac{rB_0}{R_0} + 1 \right) &= rT \quad \text{if } \frac{rB_0}{R_0} + 1 > 0 \\ \Leftrightarrow \frac{1}{r} \ln \left(\frac{rB_0}{R_0} + 1 \right) &= T \end{aligned}$$

Thus, the resource will be exhausted at time T when r is positive. If $r = 0$ holds, then the resource will be exhausted at time $T = B_0 / R_0$. In the case $r < 0$, obviously T can be determined only if

$$\frac{rB_0}{R_0} + 1 > 0$$

holds. What does this mean mathematically? The conjecture is that the resource will be available infinitely if the condition is not satisfied. To check this, consider the following integral (with $r < 0$):

$$\begin{aligned}\bar{S} &= \int_0^{+\infty} R(t) dt = \lim_{b \rightarrow +\infty} \int_0^b R(t) dt = \lim_{b \rightarrow +\infty} \left[\frac{R_0}{r} e^{rt} \right]_0^b \\ &= \lim_{b \rightarrow +\infty} \left(\left(\frac{R_0}{r} e^{rb} \right) - \left(\frac{R_0}{r} e^{r0} \right) \right) = \lim_{b \rightarrow +\infty} \left(\frac{R_0}{r} e^{rb} \right) - \lim_{b \rightarrow +\infty} \left(\frac{R_0}{r} e^{r0} \right) = -\frac{R_0}{r}\end{aligned}$$

The result shows that the cumulative resource consumption over an unbounded period $[0; +\infty[$ is not unbounded at all, but $-R_0 / r$. Thus, if this value is less than or equal to B_0 , it follows:

$$-\frac{R_0}{r} \leq B_0 \quad \Leftrightarrow \quad r \leq -\frac{B_0}{R_0}$$

Then the resource is not depleted. We summarize the results:

Theorem 9: Exhaustible resources

Assume A.1 and A.2. The resource will be exhausted at time T if and only if

$$r > -\frac{R_0}{B_0}$$

In other cases, the resource is available everlasting.

As before, the essential facts can be represented graphically (see Figure 4).

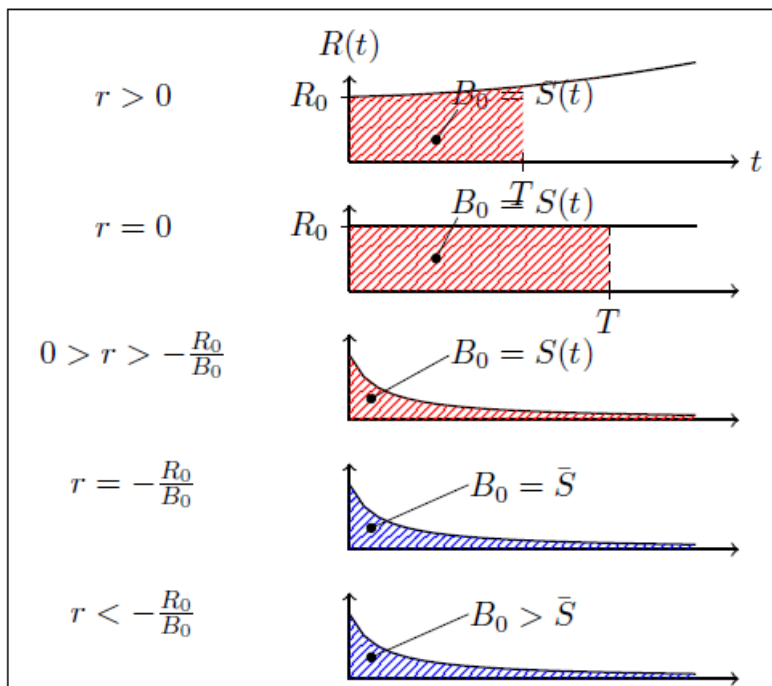

Figure 4: Exhaustible resources

A small case study: In 2019, there were 245 billion tons of crude oil reserves worldwide. Consumption in 2019 was 4.46 billion tons (Source: Statista Research Department, 2023). If consumption remains constant, the reserves will be exhausted after 54.9 years. At a growth rate of

$$r = -\frac{R_0}{B_0} = -\frac{4,46}{245} = -1,8\%$$

the reserves are not exhausted. This result is quite important with respect to the question of crude oil availability. If consumption were to decrease slightly worldwide, crude oil would be available everlasting.

Differentials: What drives economic growth?

Differentials are used very intensively in economics. The value of differentials can be demonstrated by the very simple model of growth accounting, which can be used to determine the main determinants of the growth rate of aggregate output. The starting point is a macroeconomic production function that establishes a relationship between factor inputs (here: labor input L and capital input K) and output Y . Furthermore, we assume that factor inputs change over time. This leads to following model:

Model 5: Growth accounting

A.1 We assume the following production function (with $K > 0$, $L > 0$, $Y > 0$) with first partial derivatives:

$$Y = Y(K, L)$$

A.2 We assume (with t for time)

$$K = K(t) \quad L = L(t)$$

where both functions are differentiable.

A change of Y results from a change of K or L . This can be represented using the total differential:

$$dY = \frac{\partial Y}{\partial K} dK + \frac{\partial Y}{\partial L} dL$$

Since we are considering changes in time t , we divide by dt :

$$\frac{dY}{dt} = \frac{\partial Y}{\partial K} \frac{dK}{dt} + \frac{\partial Y}{\partial L} \frac{dL}{dt}$$

Since the determinants of the growth rate of Y are to be identified, we divide by Y :

$$\frac{dY}{dt} \frac{1}{Y} = \frac{\partial Y}{\partial K} \frac{1}{Y} \frac{dK}{dt} + \frac{\partial Y}{\partial L} \frac{1}{Y} \frac{dL}{dt}$$

It follows:

$$\frac{dY}{dt} \frac{1}{Y} = \frac{\partial Y}{\partial K} \frac{K}{Y} \frac{dK}{dt} \frac{1}{K} + \frac{\partial Y}{\partial L} \frac{L}{Y} \frac{dL}{dt} \frac{1}{L}$$

Define:

$$g_Y = \left(\frac{dY}{dt} \right) / Y \quad g_K = \left(\frac{dK}{dt} \right) / K \quad g_L = \left(\frac{dL}{dt} \right) / L$$

$$\varepsilon_{Y;K} = \left(\frac{\partial Y}{\partial K} \right) / \left(\frac{Y}{K} \right) \quad \varepsilon_{Y;L} = \left(\frac{\partial Y}{\partial L} \right) / \left(\frac{Y}{L} \right)$$

Finally, we have:

Theorem 8: Determinants of output growth rate

Assuming A. and A.2, we have:

$$g_Y = \varepsilon_{Y;K} g_K + \varepsilon_{Y;L} g_L$$

The growth rate of output g_Y is taken as determined by the growth rates of factor inputs (g_K , resp. g_L) weighted by the partial elasticities of production ($\varepsilon_{Y;K}$, resp. $\varepsilon_{Y;L}$).

Clearly, this model does not explain very much yet. Using more sophisticated models, the growth rates of factor inputs (i.e., g_K and g_L) are also explained. For empirical growth research, the growth accounting model plays an important role, because under certain assumptions (including profit maximization of firms) the partial production elasticities are obtained as input coefficients. The application shows in an exemplary way that economics works very pragmatically with differentials. In particular, the view usually taught in school that a differential quotient dy/dx is not a quotient is not represented.

A final remark: as in all sciences, one strives to obtain results that are as general as possible. This goal is achieved here to the extent that no special class of production functions (such as Cobb-Douglas production functions) needs be assumed. The production function only has to be partially differentiable once.

Epilogue

This article deals with teaching calculus in ME. First, I explained that essential framework conditions have an influence on teaching in ME. Then, I presented six features of ME (modeling, simplifications, heuristics, application / examples, diagrams / graphical representations, measurement) that are widely used in ME. For illustration, I presented four examples.

To my impression, teachers of core mathematics do not use these features so often as teachers of ME. Moreover, teachers of core mathematics may evaluate some of them critically. Obviously, it is unclear how meaningful the listed features are and whether there is room for improvement in teaching ME. One problem is that there are no strong scientific discourses between teachers and researchers from the fields of economics, mathematics and didactics. Moreover, there seems to be a lack of networks of the actors working trustfully together. For example, in Germany exists only few networks dealing with ME (cf. Centre for Higher Mathematics Education (“Kompetenzzentrum Hochschuldidaktik Mathematik”, khdm, www.khdm.de); Network Teaching-learning groups in mathematics-containing degree programs (“Lehr-Lern-Verbünde in mathematikhaltigen Studiengängen”, LLV.HD, <https://www.uni-kassel.de/go/llv-hd/>).

In such networks, it could and should be discussed whether the features addressed are used sensibly and adequately in the sense of good teaching of ME. Thus, assessments of actors from mathematics and didactics are needed. However, the associated exchange is certainly not a one-way street. The pragmatism necessary in ME in teaching mathematics (and the associated use of certain features) as well as the strong focus on (economic) applications may also have the potential for inspiring teaching in core mathematics.

Finally, I should note again that parts of the discussion in this paper have the character of a case study. Moreover, I have written the paper against an economic background. The features and applications presented are (similarly) the subject of my lecture ME in an economics and business administration study program. The short remarks on the agenda and specifically on networks are inspired by my research work done during several years of work at an economic research institute. All of this implies a certain degree of subjectivity. Nevertheless, the statements should be broadly representative for ME. I hope so. Which could be clarified in a network of ME. As soon as possible...

Acknowledgment

Many thanks to John Monaghan and Frank Feudel, and to all the students, tutors, research assistants and colleagues who have supported me with critical advice and comments on my teaching in ME over the past 15 years.

References

Allgood, S., Walstad, W. B., & Siegfried, J. J. (2015). Research on Teaching Economics to Undergraduates. *Journal of Economic Literature*, 53(2), 285-325. doi:10.1257/jel.53.2.285

Arrow, K. J., & Debreu, G. (1954). Existence of an equilibrium for a competitive economy. *Econometrica*, 22, 265-290.

Blanchard, O. (2021). *Macroeconomics. Global edition* (8 ed.): Pearson.

Büchele, S., Berndt, S., & Felix, A. (2022). Voluntary math remediation for STEM and economics disciplines – who is attending at all? Evidence from Germany. *European Journal of Higher Education*, 1-20. doi:10.1080/21568235.2022.2118148

Büchele, S., & Feudel, F. (2023). Changes in Students' Mathematical Competencies at the Beginning of Higher Education Within the Last Decade at a German University. *International Journal of Science and Mathematics Education*. doi:10.1007/s10763-022-10350-x

Büchele, S., Liebendörfer, M., & Lankeit, E. (2021). Increasing the effect of a remedial mathematics course by switching to an online format during the COVID-19 crisis: evidence from a German university. *Teaching Mathematics and its Applications: An International Journal of the IMA*, 40(4), 478-496. doi:10.1093/teamat/hrab013

Chiang, A. C., & Wainwright, K. (2005). *Fundamental Methods of Mathematical Economics* (4 ed.). Boston: McGraw-Hill.

Feudel, F. (2020). *Die Ableitung in der Mathematik für Wirtschaftswissenschaftler. Analysen zum benötigten, gelehrten und von Studierenden erreichten Verständnis des Ableitungsbegriffs*. Wiesbaden.

- Feudel, F., & Biehler, R. (2022). Students' Understanding of the Economic Interpretation of the Derivative in the Context of Marginal Cost. *International Journal of Research in Undergraduate Mathematics Education*, 8(3), 437-468. doi:10.1007/s40753-021-00144-x
- Gigerenzer, G., Hertwig, R., & Pachur, T. (Eds.). (2011). *Heuristics: The Foundations of Adaptive Behavior*: Oxford University Press.
- Gräbner, C., & Strunk, B. (2020). Pluralism in economics: its critiques and their lessons. *Journal of Economic Methodology*, 27(4), 311-329. doi:10.1080/1350178X.2020.1824076
- Hodgson, G. M. (Ed.) (2012). *Mathematics and Modern Economics*. Cheltenham.
- Laging, A., & Voßkamp, R. (2016). Identifizierung von Nutzertypen bei fakultativen Angeboten zur Mathematik in wirtschaftswissenschaftlichen Studiengängen. In A. Hoppenbrock, R. Biehler, R. Hochmuth, & H.-G. Rück (Eds.), *Lehren und Lernen von Mathematik in der Studieneingangsphase* (pp. 585-600). Wiesbaden: Springer.
- Laging, A., & Voßkamp, R. (2017). Determinants of math performance of first-year business administration and economics students. *International Journal of Research in Undergraduate Mathematics Education*, 3, 108-142. doi:10.1007/s40753-016-0048-8
- Merz, M. (2013). *Mathematik für Wirtschaftswissenschaftler*. München: Vahlen.
- Reiffen, H. J., & Trapp, H. W. (1999). *Einführung in die Analysis*. Osnabrück: Universitätsverlag Rasch.
- Samuelson, P. A. (1947). *Foundations of economic analysis* (1 ed.). Cambridge, Mass. u.a.
- Simon, C. P., & Blume, L. (2000). *Mathematics for Economists*. New York: Norton & Company.
- Statista Research Department (2023). *Data on Global Crude Oil Reserves and Consumption*. Retrieved from: www.statista.com
- Stigler, G. J., Stigler, S. M., & Friedland, C. (1995). The Journals of Economics. *Journal of Political Economy*, 103(2), 331-359. Retrieved from <http://www.jstor.org/stable/2138643>
- Sydsæter, K., Hammond, P. J., Strøm, A., & Carvajal, A. (2021). *Essential mathematics for economic analysis* (6 ed.): Pearson.
- Voßkamp, R. (2017). Mathematics in economics study programs in Germany: structures and challenges In R. Göller, R. Biehler, R. Hochmuth, & H. G. Rück (Eds.), *Didactics of Mathematics in Higher Education as a Scientific Discipline. khdm-Report 17-05* (pp. 184-189). Kassel: khdm.
- Voßkamp, R. (2023, work in progress). *Mathematics for Economists*. Univ. of Kassel. Kassel.
- Voßkamp, R. (2023, work in progress). *Textbooks on Mathematics for Economists*. Univ. of Kassel. Kassel.
- Wilkinson, N. (2005). *Managerial Economics*. Cambridge: Cambridge University Press.

Introductory physics: Drawing inspiration from the mathematically possible to characterize the observable

Suzanne White Brahmia

University of Washington, Seattle, USA; brahmia@uw.edu

Abstract

A calculus that characterizes the interaction between quantities, and the mathematical implications of those interactions, will help prepare students who take physics to use mathematics for quantifying the natural world, and uncovering its laws. In this talk I characterize essential features of reasoning with quantity in physics, and some implications for the teaching of calculus.

Introduction

Conceptually understanding what calculus is doing when its most basic functions represent relations between physical quantities is a more valuable learning outcome for students of physics than demonstrating mastery of multiple integration techniques in the contexts of challenging integrals, or knowing cold the tests of convergence for unfamiliar series.

Here is why:

1. A proceptual facility with functions whose variables are scalar or vector quantities is a central feature to expert reasoning in physics. Instructors expect students to have quick facility with as well, based on their prerequisite math courses.
2. The relationship between physical quantities, their change, their rates of change with respect to time and position, and their accumulation from these rates of change is central to understanding the meaning of the laws of physics.
3. The clear majority of the models in introductory physics involve linear, inverse, sine, cosine and quadratic functions. Students are expected to know the derivatives and antiderivatives of **these** functions, symbolically and graphically, as well as their behavior at physically significant points and extreme cases.

A significant majority of the students who are taking calculus in the US at any given time will subsequently take introductory physics - with the main exception being calculus courses for business and economics majors. We argue that rate and accumulation reasoning are likely important for all calculus students, even those who won't take a physics course.

In calculus and in introductory physics, we are essentially teaching the same students. But do they perceive what we are doing as being the same things? Arguably, students are "culture-shifting" between doing math and doing physics, which limits the quantitative resources they tap into when taking a physics course. Bajracharya, Sealey and Thompson interviewed math majors as part of a study to uncover how they made sense of a negative definite integral. They observed that invoking a

physics example of a stretched spring helped catalyze sense making. Although the physical context helped math majors conceptualize the accumulation, there was a perceived departure from the pure math world to make meaning, as articulated by one interviewee, “when you think about just, like, the pure math problems, that’s all you really think about — just the fact that dx is just telling you ... what variable to use (in the integral) ... but ... here, it represents, it represents something...” (Bajracharya, Sealey and Thompson 2023). In physics, every variable represents something physical, we'd like students to imagine the potential of x and y in calculus to represent a whole variety of quantities, even when they're not prompted.

It is challenging to serve all the future needs of the students in a service course as ubiquitous as calculus. Physics is asking for just a bit less breadth in the interest of more depth, such that students can spontaneously decide that taking an integral, or a derivative, or representing a function as a series, is a sensible thing to do in a physics context. Why would you integrate? When is it useful to approximate a function by terms in a series? And can do it as well. The tradeoff is that by considering the interplay between quantities: fundamental quantities, their rates of change, and the accumulation of the product quantities they form, can perhaps help a more diverse group of students conceptualize calculus as well.

There is a natural tension between the learning objectives of a calculus course and what students really need for a physics course. It is true that our worldviews differ. Physics is about modeling the physical world by inventing quantities and their relationships to each other. The ultimate test of models is if they predict what happens in nature. Validated models represent the corpus of knowledge in physics. Mathematics has different constraints, and its validity test is logical proof. Developing reliable capacity to solve problems is an added utilitarian emphasis in both disciplines, to make sure that students can "do" math/physics after having taken a course. While becoming efficient at problem solving is an important learning objective, an excessive focus on sharpening this skill comes at a price. Much is missing in the quantitative reasoning behind why we do what we do, rendering most students unaware as to how they can use their quantitative insight to think creatively in physics.

There is mounting evidence that students struggle with conceptualizing arithmetic and algebra as used in introductory physics (Kuo, Hull, Gupta, & Elby, 2011, White Brahmia, Olsho, Smith, Boudreaux, Eaton, & Zimmerman, 2021). These difficulties carry over into subsequent course taking. In a summary of studies on mathematical reasoning in upper-division physics, the authors found the following common student difficulties, despite having taken many math courses beyond the calculus level:

- activating appropriate mathematical tool without prompting (e.g. delta function, Taylor series)
- recognizing meaning of mathematical expressions
- spontaneous reflection on results (e.g., limiting cases, dimensional analysis)
- generating mathematical expressions from physical description

The students had no problems with executing the mathematics when asked, but they expressed a strong desire to understand what they were doing, and why (Caballero, Wilcox, Doughty, and Pollock, 2015).

This paper explores current educational research focusing on the salient aspects of how some important calculus concepts appear in introductory physics teaching, with recommendations of materials that can help foster a conception of calculus that promotes physics reasoning.

Calculus in introductory physics

Expert physics modeling involves significant overlap of the mathematical and physical worlds

Consider current a priori cognitive models of modeling in physics and in math contexts, on which classroom mathematical modeling activities are framed. The concept of a *cycle* is ubiquitous, exemplified by the Modeling Cycle shown in Figure 1 (Blum & Leiß, 2007, Czocher, 2016). Note the complete separation of the math world and the rest of the world in the mental process. The model implies that mathematizing is done largely in a separate mental place from the context in which it is being done.

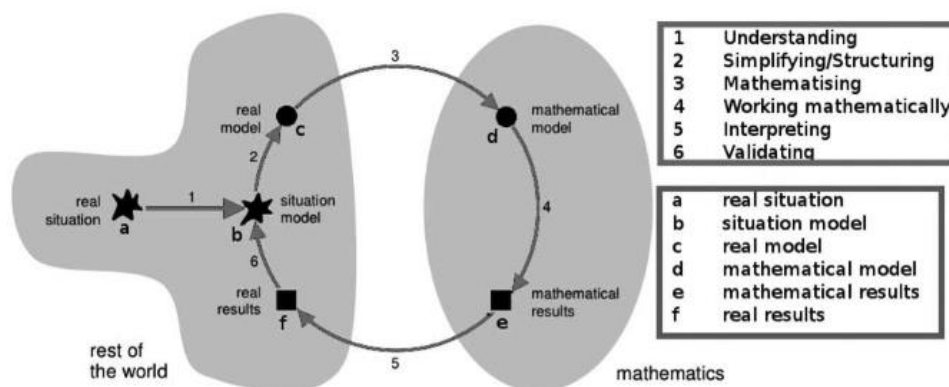

Figure 1: Czocher's redraft of Blum and Leiß's modeling cycle (Blum & Leiß, 2007, Czocher, 2016)

In contrast to the apriori cyclic models, researchers in mathematics education have found little evidence that students' reasoning while modeling is cyclical (Borromeo Ferri, 2007, Ärlebäck 2009). In a recent study, Czocher (Czocher, 2016) conducted interviews throughout an academic term of four engineering majors enrolled in a differential equations course. In each interview, the students were observed solving problems in everyday contexts that required generating mathematical descriptions from a variety of branches of mathematics, including differential equations. The author describes a much finer-grained blending of mathematical reasoning and physical sense-making than is represented in apriori cyclic models of modeling, specifically that "there are transitions that appear out-of-order. This was largely because three of the modeling transitions (understanding, simplifying/structuring, and validating) appeared early and often throughout the students' modeling processes." The importance of continuous validation to the progress of their mathematization is not predicted by the apriori models. Czocher presents a fine-grain description of the interpreting and validating that was observed, a portion is reproduced in Table 1.

The students who were less successful spent little time validating, while students who were more successful spent much more time on validation. The subset of skills listed in Table 1 involved in interpreting and validating are precisely the skills physics counts on its students mastering to be successful at modeling in physics -- they are central to mathematization in physics.

<i>Interpreting</i>	Re-contextualizing the mathematical result	<ul style="list-style-type: none"> • Referring to units • Answering contextual question, not just mathematical one • Interpreting meaning from an equation or its elements, or from the mathematical representation • Referring to conditions/variables/parameters from “simplifying/structuring”
<i>Validating</i>	Verifying results against constraints	<ul style="list-style-type: none"> • Statements about reasonableness of answer/model • Checking extreme cases and special cases (of variable, parameter, relationship) • Comparing answer to a known result • Estimating an appropriate result • Adding limitations to the model • Talking about ideal results • Comparing merits of different models • Dimensional analysis

Table 1: Adapted from Czocher 2016 (Czocher, 2016)

In Zimmerman, Olsho, Loverude and White Brahmia's study of expert modelers in physics (graduate students and faculty), interviewees were asked to create graphical solutions for novel physics tasks (Zimmerman, Olsho, Loverude & White Brahmia, under review). The tasks were isomorphic versions of the kinematics tasks used in the study by Hobson and Moore (Hobson & Moore, 2017), but rendered more challenging for expert physicists by invoking abstract contexts and quantities. For example, “Going around Gainesville”, which asks the interviewee to generate a graph of the distance of a car from Gainesville as a function of the distance it has travelled along the road, became a charged probe moving around a small charged sphere. The task prompts participants to create a graph that relates the electric potential and the total distance traveled, as it moves at constant speed from start to finish.

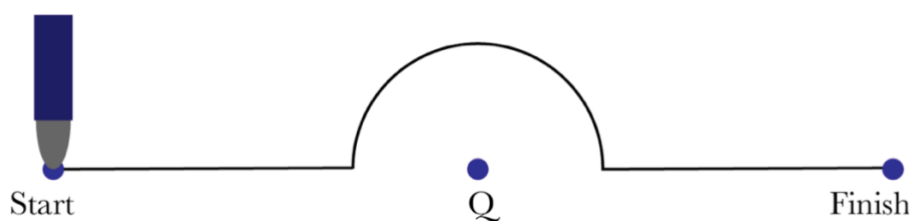

Figure 2: Still from the animation associated with example task (Zimmerman et al. 2023)

Zimmerman et al. report many of the mental actions included in Czoachers's description of validation are precisely the features that characterize aspects of the study participants' covariational reasoning - specifically their simplification techniques and their tools for covariation when modeling novel physics tasks. A subset of the expert physicists reasoning methods uncovered in this study are represented in the behaviors in Table 1. We note that reasoning with units, dimensional analysis, checking extreme cases, simplifying/structuring and interpreting meaning from an equation and its elements are all essential ingredients in physics modeling.

Many physics students struggle to naturally take up these behaviors in a physics course if they never encountered them in a math course before. In a study conducted by Rowland in the context of a differential equations course, the author found that despite having completed introductory physics, over half of the engineering students were not confident about linking the mathematical expressions they were creating to the physics phenomena they represent, and the clear majority failed to incorporate the notion that the units of each term in the model should be the same (Rowland, 2006). The author argues "a consideration of units, how they combine, and how they can be used to analyze systems in modelling contexts needs to be an explicit part of instruction." The disconnect between amount and its unit is as much of a problem with physics instruction as it is with mathematics, and it is one we can solve collectively by expanding the overlap of our worlds, such that they aren't perceived by our students as separate mental places.

Quantities are central to the laws of physics

Quantities in physics are either scalars or vectors, and are commonly the result of multiplying and dividing other quantities (e.g., momentum, density). Procedurally, the arithmetic involved in creating new quantities is not a challenge for most students, however deciding when and why the arithmetic makes sense can pose a significant challenge (Thompson, 2011). Vergnaud argues that multiplication, division, fraction, ratios, proportions, linear functions, dimensional analysis and vector spaces are not mathematically independent, and should be included in a domain he names multiplicative structures (Vernaud, 1998). Tuminaro reports on student difficulties conceptualizing the simplest multiplicative structures in physics contexts (Tuminaro,2007).

Quantification produces the physical quantities that are used in physics modeling, and it relies on blending physics meaning with a conceptualization of multiplicative structures. For experts, the blending of the mathematical concepts with physics quantities happens unconsciously and seamlessly (Zimmerman et al., under review, Kustusch, Roundy, Dray, & Manogue, 2014). Expert-like math-physics blending is a desired learning outcome of an introductory physics course, yet it needs to be nurtured as part of instruction for students to understand and develop creativity as they learn to interpret physics models. We suggest that the foundation for this blending can be part of a calculus course. For that to happen, we should agree on what we mean by representing quantity.

Sherin developed a symbolic form framework that explains how successful students understand and construct equations in physics. The symbolic form framework posits that students have conceptual schema associated with specific symbolic patterns (e.g. the *ratio* form) commonly invoked to

compare two quantities $\left[\frac{x}{y}\right]$ (Sherin, 2001). Dorko and Spear developed the *Measurement* symbolic form in the context of area and volume in mathematics, which always includes a unit as well as a value (Dorko & Spear, 2015). The authors argue that the units are an important part of students' conception of measurement. I make the argument that in physics, where we use the term *quantity* instead of measurement, this form should also include a sign, as most quantities students work with in an introductory physics course are vector components and other signed quantities. (White Brahmia, 2019, White Brahmia, Olsho, Smith, Boudreaux, 2020, Olsho, White Brahmia, Smith, & Boudreaux, 2021, White Brahmia et al. 2021). The units and the sign carry important meaning, and I suggest that students can be better primed for this onslaught in physics if they encounter quantity in this way in a calculus course.

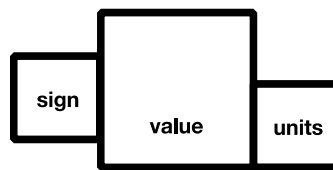

Figure 3: The Quantity symbolic form relevant to physics builds on the Measurement symbolic form by including sign (White Brahmia, 2019, Dorko & Spear, 2015)

Both Czocher's and our (Zimmerman et al, under review) studies provide evidence that successful students, and experts, derive physical meaning from "an equation or its elements" (see Table 1), which are measured or derived quantities in physics models. Calculus provides a mental framework for thinking about the relationships between quantities in physics, and for imagining new ones. The clear majority of quantities in physics have an amount/change/rate/accumulation relationship.

Figure 4 shows a plot of how some fundamental quantities in physics (examples shown are from mechanics) are mathematically processed to create new quantities that eventually play a central role in the fundamental laws of mechanics – Newton's laws and the conservation laws of momentum, energy and angular momentum. The fundamental quantities are directly measurable. All the rest are derived from these measurable quantities. While each of these quantities is sometimes combined with the same type of quantity through arithmetic operations (lengths combine for area, displacement, etc.) many of the quantities that are involved in the laws of physics are related to each other as rates and accumulations (i.e. "area under the curve"). We adopt "accumulation" as has been put forward by Thompson and others, as it holds much more potential for student comprehension in a physics context than area-under-the-curve does. None of these important quantities are actual areas. The notion of the derivative/antiderivative/accumulation/change relationships are so important in physics, that frequently they are created as new quantities and given their own name - connected through the Fundamental Theorem of Calculus (FTC).

Samuels' Amount Change Rate Accumulation (ACRA) framework of the FTC shows promise for supporting students of physics to conceptualize these relationships (Samuels, 2022, Samuels, 2023) in the context of a calculus course (see shaded region of Table 2). I've applied the ACRA framework in the unshaded region of Table 2 to demonstrate the essential role the FTC plays understanding the generation of physics quantities, and the physical laws that relate them to each other.

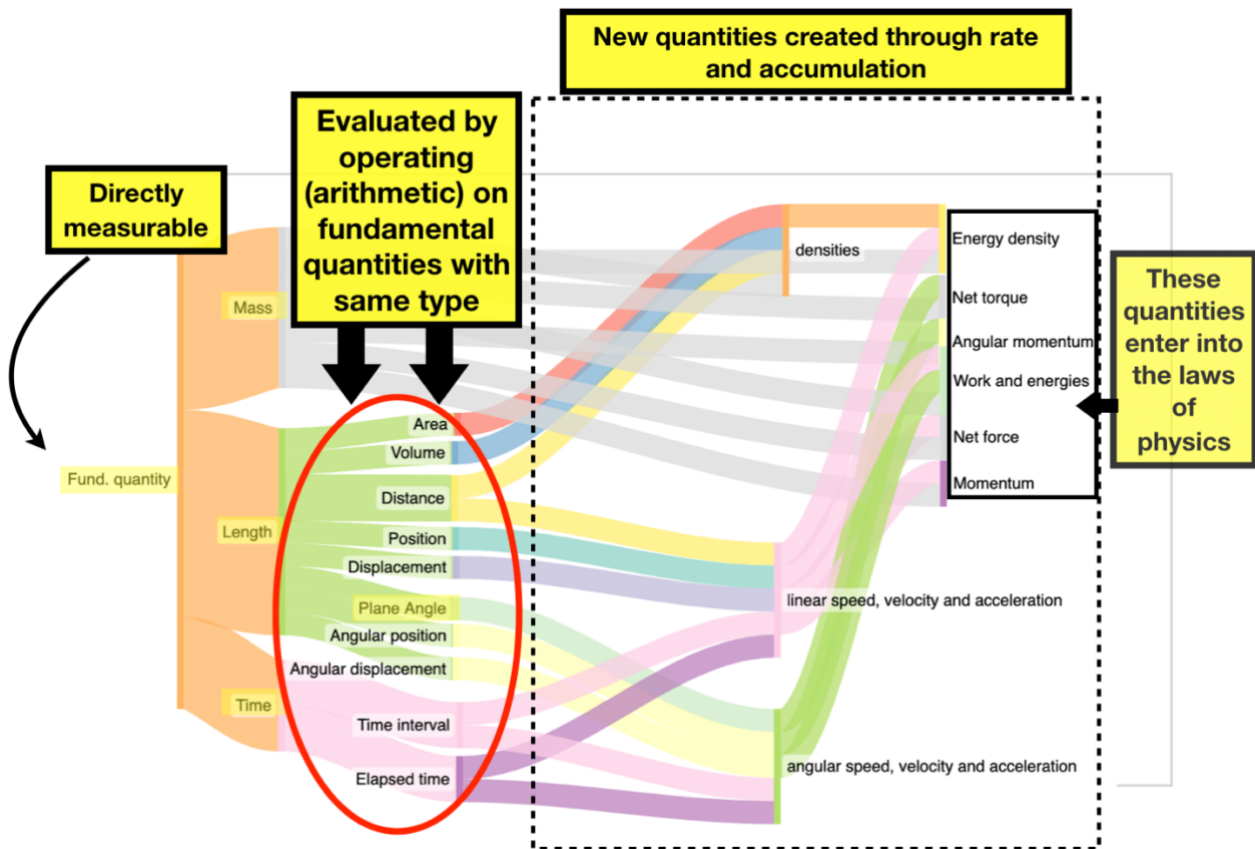
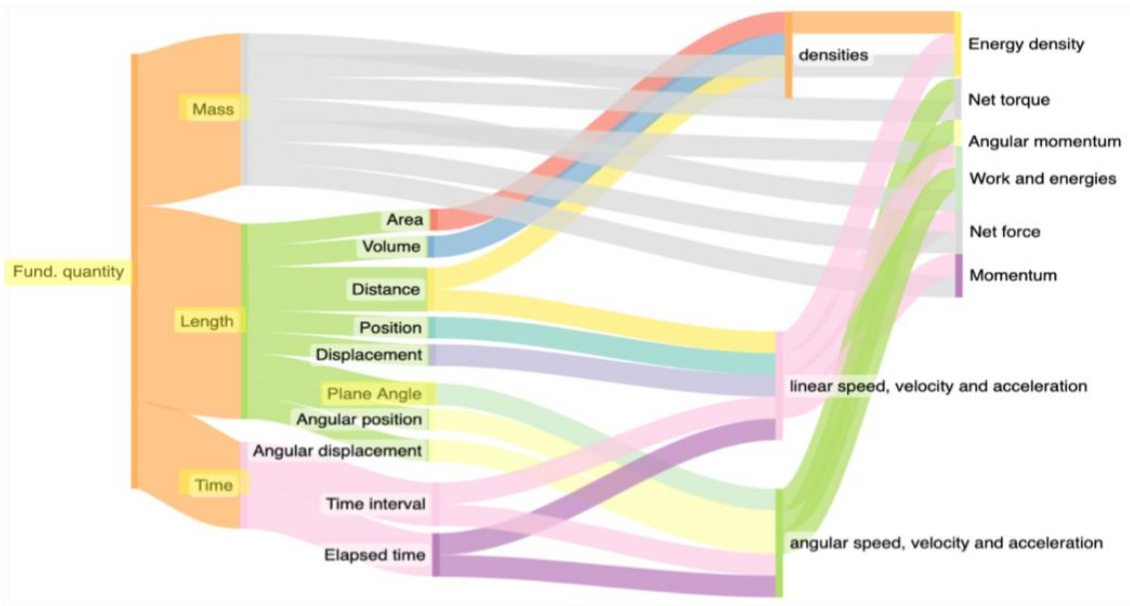

Figure 4: Quantities encountered in introductory mechanics

I argue that quantification is the neglected first step in modeling in physics (White Brahmia, 2019), a neglect that increases the likelihood that students' beliefs about doing physics is that their job is to find the right equation (Kuo, Hull, Gupta, & Elby, 2011, Hammer, 1989). The notion that they can participate in the mathematical creativity of quantification, and modeling, is largely lost on them. Physics has a long way to go such that all students feel confident in their capacity to engage in creative mathematization. Given the preponderance of calculus concepts involved, deepening students' conceptual understanding of what they are doing and why they are doing it in calculus can help students' feel more confident modeling in physics.

Expert Modeling in physics involves a small number of functions

Models in physics typically involve only a small finite number of functions. At the level of introductory mechanics, the laws of physics are dominated by linear and inverse functions, with the more complex combinations of functions that are frequently addressed in a calculus course rarely or never appearing.

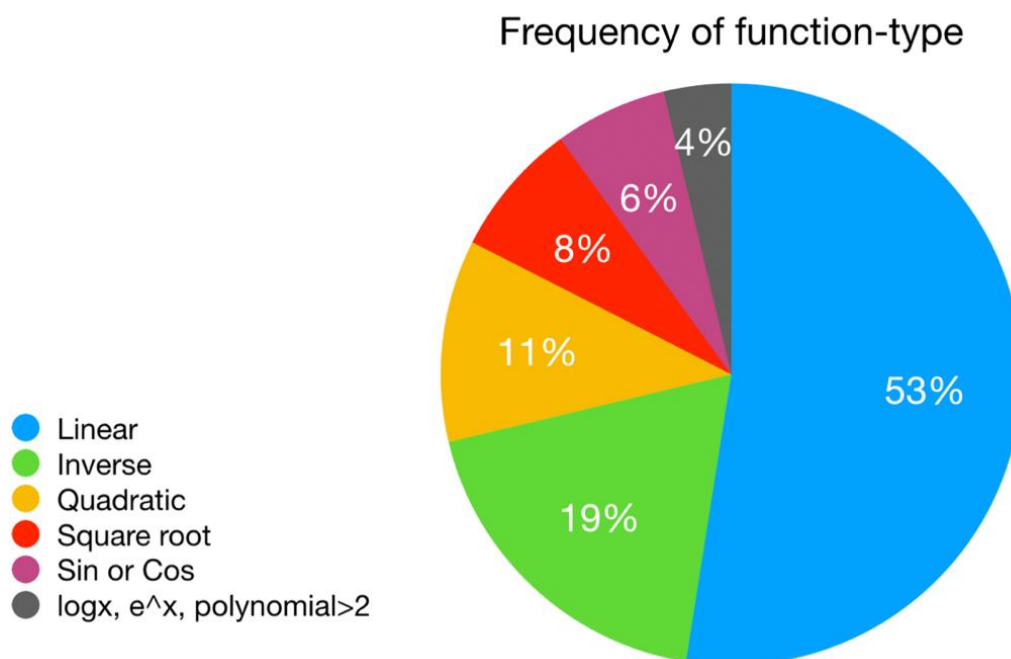

Figure 5: Functions encountered in introductory mechanics

I generated Figure 5 by going through a list of the essential formulas for introductory physics, which is representative of just about any standard college physics textbook, and sorting it by function type, noting the frequency of appearance for each function type. The uncertainty on the values shown is likely a few percent. Each of the limited number of functions listed in Figure 5 are central to the covariational reasoning of physics.

Physics quantity	$f(b) - f(a)$	=	$\int_{x=a}^{x=b} df$	=	$\int_a^b \frac{df}{dx} dx$	=	$\int_a^b f'(x) dx$
	Total change (accumulation)		Infinite sum of every infinitesimal change		The integral (infinite sum) of every (infinitesimal change) \div (infinitesimal input change) \times (infinitesimal input change)		The integral (infinite sum) of infinitesimal rate (as a function) times infinitesimal input change
displacement	$x(t_2) - x(t_1)$	=	$\int_{t=t_1}^{t=t_2} dx$		$\int_{t_1}^{t_2} \frac{dx}{dt} dt$		$\int_{t_1}^{t_2} v(t) dt$
	Change in position		Same as above...in position		Same as above		The integral of the (signed) velocity times tiny time intervals
Δv (Needs a name!!)	$v(t_2) - v(t_1)$	=	$\int_{t=t_1}^{t=t_2} dv$		$\int_{t_1}^{t_2} \frac{dv}{dt} dt$		$\int_{t_1}^{t_2} a(t) dt$
	Change in velocity		Same as above...in velocity		Same as above		Same as above (acceleration)
impulse	$p(t_2) - p(t_1)$	=	$\int_{t=t_1}^{t=t_2} dp$		$\int_{t_1}^{t_2} \frac{dp}{dt} dt$		$\int_{t_1}^{t_2} F(t) dt$
	Change in momentum		Same as above...in momentum		Same as above		Same as above (force)
work done on system	$U(x_2) - U(x_1)$	=	$\int_{x=x_1}^{x=x_2} dU$		$\int_{x_1}^{x_2} \frac{dU}{dx} dx$		$\int_{x_1}^{x_2} F(x) dx$
	Change in potential energy		Same as above...in potential energy		Same as above		The integral of the (signed) force times tiny displacements

Table 2: My extension of ACRA (shaded) FTC to include important physical quantities (unshaded)

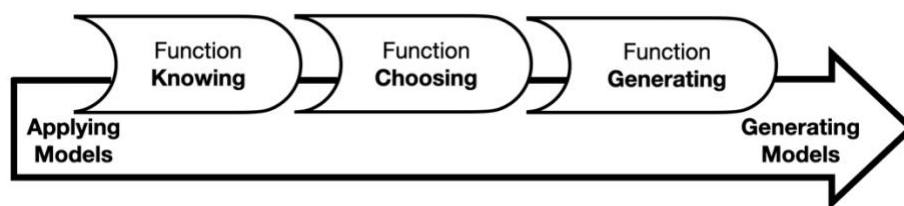

Figure 6: Experts interaction with functions when modeling

Knowing what they look like graphically, how they behave covariationally, how they behave in the limits of very large and very small values of the independent variable, and any other special cases that are specific to the function (e.g. min/max/zeros/special arguments of sine or cosine functions) facilitates modeling for experts (Zimmerman et al, under review). Students who have this deep understanding of these functions before taking a physics course will be at a significant cognitive advantage; it is expected knowledge. In the Zimmerman et al study, we found that when modeling, experts engaged in behaviors of function knowing, function choosing or function generating – which become more cognitively demanding moving from left to right in Figure 6. Experts first look for a function they know based on a similar context (e.g. circular motion invokes sinusoidal functions), and if that fails they tend to choose from the list in Figure 5. If that is unsuccessful, then they try generating a graphical function by invoking covariational reasoning tools (see Table 1 and Zimmerman et al.), designating several physically significant points. They engage in “neighborhood analysis” by considering the first derivative in the neighborhood of these points, and then connecting the points with a line or curve, by considering the 2nd derivative behavior between the points.

An important feature of function choosing and function generating is that they are generally evoked in the context of some sort of data that might (or might not) show a trend consistent with a meaningful function. This modeling scenario is ubiquitous in physics, whether graphically modelling an imaginary situation, or collecting actual data in an experiment and modeling the patterns that emerge from the data. Clean analytical solutions are the exception rather than the norm beyond the introductory course when comparing the real-world patterns to mathematical functions. Making approximations are a standard part of rendering a messy physical system tractable. Einstein famously said, "Everything should be made as simple as possible, but not simpler." Rather than resorting to messy functions, we always hope for one of the functions in Figure 5. Series representations of those functions, especially their first couple of terms, become a standard tool for modeling the physical world beyond the introductory course, and are even invoked in a couple of contexts there as well (e.g. small angle approximation for simple pendulum). Knowing how common approximations are used, and why, would be a wonderful outcome of calculus for physics students.

Recommendations for the teaching of calculus

While I’m not an expert in calculus instruction, I understand that changing the content in courses as institutionalized as tertiary-level calculus courses are in the United States is not straightforward. I suggest here some effective, research-validated materials that help students construct their mathematical knowledge in the contexts of quantity. They were all designed to be used in the context of classroom instruction, ideally in collaborative learning environments.

Developing conceptual foundation

[Physics Invention Tasks](#) (White Brahmia, Kanim, Boudreaux): Designed to engage students in authentic quantification, in preparation for subsequent formal learning. Students use data from contrasting cases to invent ratio or product quantities, rules or equations to characterize a variety of physical systems. Students work through sequences of such tasks to ramp up from everyday contexts to more abstract physics contexts. We have field tested sets of invention tasks, called invention sequences, both at the pre-college level, in middle school and high school, and in a variety of introductory physics courses, from pre-service teachers to engineering students. <https://depts.washington.edu/pits/Background.html>

[Precalculus: Pathways to Calculus](#) (Carlson, Oehrtman, Moore, O'Bryan):

Textbook, workbook and supplemental materials that facilitate student construction of calculus ideas that are particularly relevant in physics, especially constant rate of change and linear function, and changing rates of change, using covariation. Includes vector quantities, sequence and series representation as approximation. Focusses on less breadth in the variety of functions in favor of building a deeper understanding of the functions themselves using multiple representations and many relevant applications, while students are constructing their knowledge, not as an afterthought. <https://www.greatriverlearning.com/product-details/2212>

Calculus course activities

[DIRACC Calculus](#): (Thompson, Ashbrook, Milner) The intention of this work is that students understand a calculus that is about more than lines, areas, and pseudo connections with quantitative situation, with focus on their reasoning about quantities and relationships among quantities. The focus on the FTC as relating rates of change and accumulations such that students must conceptualize rate of change as a relationship between quantities who vary is well-aligned our students needs. The use of dynamic graphs as a representation is brilliant, and will help prime students for the ubiquitous reference to “goes like” reasoning their instructors use from the very first day (Zimmerman, Olsho, White Brahmia, Boudreaux, Smith, & Eaton, 2020). <http://patthompson.net/ThompsonCalc>

[ACRA framework](#): The relationships between quantities of single-variable calculus can be described using the ACRA Framework (Samuels, 2022, Samuels 2023). An example of a quantity-focused approach to the FTC is in the shaded region of Table 2. This mode of reasoning entails “conceptualizing a situation in terms of quantities and relationships among quantities” (Thompson & Carlson, 2017), where a quantity is a measurable attribute combined with a way to measure that attribute. ([contact Joshua Samuels](#) directly for materials)

[CLEAR Calculus](#): (Oehrtman, Tallman, Reed, Martin) Instructional activities that generalize across contexts to extract common mathematical structure, that are designed to foster quantitative reasoning and modeling skills required for STEM fields. Students both develop useful tools, and engage in activities that reveal the mathematics to be learned, thereby developing productive understandings that can serve as a strong foundation for further study in math and science. The approach to approximation here is well-suited to physics students. <https://clearcalculus.okstate.edu/>

Conclusion

A calculus course could include many fascinating topics that can unleash quantitative imagination and creativity. I've argued that for those calculus students who intend to pursue majors that also involve taking physics courses, that a calculus that characterizes the interaction between quantities, and the mathematical implications of those interactions, will help prepare those students to use calculus ideas for quantifying the natural world, and uncovering its laws. The students will see the world through a mathematical frame, with all its wonder and potential, and try out their skills predicting what nature will, and will not, reveal through observation. Mathematizing physics is founded in measurable and derived quantities, including its sign and units. The function library of physical laws isn't vast, but conceptualizing those functions that appear is essential. Conceptually understanding what calculus is doing when its most basic functions represent relations between physical quantities opens the door for students to learn physics as Newton did. There is a growing collection of effective activities that can help calculus students learn to quantify, and deepen their facility with the formalism associated with function, changes in quantity, rates of change, accumulation and approximation. This paper was written to help foster discussions and provide impetus for the great work described herein to continue, and to inspire more to come.

Acknowledgements

I would like to acknowledge my co-authors Charlotte Zimmerman, Alexis Olsho and Michael Loverude in the work described in this paper regarding expert reasoning in physics; our work is a true collaboration and, in this venue, I am merely its spokesperson. I am indebted to the UW Physics Education Group for supporting this work in ways too varied to list here, and most especially to Lillian McDermott, posthumously, for helping build a field that takes student learning to heart. This work was partially supported by the National Science Foundation under grants DUE-1832836, DUE-1832880, DUE-1833050, and DGE-1762114.

References

- Ärlebäck, J. B. (2009). On the use of realistic fermi problems for introducing mathematical modelling in school. *The Mathematics Enthusiast*, 6(3), 331–364.
<https://doi.org/10.54870/1551-3440.1157>
- Bajracharya, R. R., Sealey, V., & Thompson, J. R. (2023). Student Understanding of the Sign of Negative Definite Integrals in Mathematics and Physics. *International Journal of Research in Undergraduate Mathematics Education*. <https://doi.org/10.1007/s40753-022-00202-y>

- Blum, W., & Leiß, D. (2007). How do Students and Teachers Deal with Modelling Problems? In *Elsevier eBooks* (pp. 222–231). <https://doi.org/10.1533/9780857099419.5.221>
- Borromeo Ferri, R. (2006). Theoretical and empirical differentiations of phases in the modelling process. *Zdm – Mathematics Education*, 38(2), 86–95. <https://doi.org/10.1007/bf02655883>
- Caballero, M. D., Wilcox, B. R., Doughty, L., & Pollock, S. J. (2015). Unpacking students' use of mathematics in upper-division physics: where do we go from here? *European Journal of Physics*, 36(6), 065004. <https://doi.org/10.1088/0143-0807/36/6/065004>
- Czocher, J. A. (2016). Introducing Modeling Transition Diagrams as a Tool to Connect Mathematical Modeling to Mathematical Thinking. *Mathematical Thinking and Learning*, 18(2), 77–106. <https://doi.org/10.1080/10986065.2016.1148530>
- Dorko, A., & Speer, N. M. (2015). Calculus Students' Understanding of Area and Volume Units. *Investigations in Mathematics Learning*, 8(1), 23–46. <https://doi.org/10.1080/24727466.2015.11790346>
- Hammer, D. (1989). Two approaches to learning physics. *The Physics Teacher*, 27(9), 664–670. <https://doi.org/10.1119/1.2342910>
- Hobson, N. & Moore, K.C (2017). Exploring Experts' Covariational Reasoning. In (Eds.) A. Weinberg, C. Rasmussen, J. Rabin, M. Wawro, and S. Brown, *Proceedings of the 20th Annual Conference on Research in Undergraduate Mathematics Education*, San Diego, California. p.664 (ISSN 2474-9346)
- Kuo, E., Hull, M. G., Gupta, A., & Elby, A. (2011). How students blend conceptual and formal mathematical reasoning in solving physics problems. *Science Education*, 97(1), 32–57. <https://doi.org/10.1002/sce.21043>
- Kustusich, M. B., Roundy, D., Dray, T., & Manogue, C. A. (2014). Partial derivative games in thermodynamics: A cognitive task analysis. *Physical Review Special Topics-physics Education Research*. <https://doi.org/10.1103/physrevstper.10.010101>

- Olsho, A., White Brahmia, S., Smith, T.I., Boudreaux, A. (2021). When Negative Is Not “Less than Zero”: Electric Charge as a Signed Quantity. *The Physics Teacher*. 59 (4): p. 253–256.
<https://doi.org/10.1119/10.0004149>
- Rowland, D. L. (2006). Student difficulties with units in differential equations in modelling contexts. *International Journal of Mathematical Education in Science and Technology*, 37(5), 553–558. <https://doi.org/10.1080/00207390600597690>
- Samuels, J (2023, in press). Student Quantitative Understanding of Single Variable. In (Eds.) Cook, S. & Infante, N., *Proceedings of the 25th Annual Conference on Research in Undergraduate Mathematics Education*, Omaha, NE (ISSN 2474-9346)
- Samuels, J (2022). Calculus Reconceptualized Through Quantities. In (Eds.) Karunakaran, S. S., & Higgins, A. *Proceedings of the 24th Annual Conference on Research in Undergraduate Mathematics Education*, Boston, MA. p.867 (ISSN 2474-9346)
- Sherin, B. L. (2001). How Students Understand Physics Equations. *Cognition and Instruction*, 19(4), 479–541. https://doi.org/10.1207/s1532690xci1904_3
- Thompson, P. W., “Quantitative reasoning and mathematical modeling”, in *New perspectives and directions for collaborative research in mathematics education*, edited by L. L. Hatfield, S. C. S. B., (University of Wyoming, Laramie, WY, 2011), p.33-57.
- Thompson, P. & Carlson, M. (2017). Variation, covariation, and functions: Foundational ways of thinking mathematically. In J. Cai (Ed.), *Compendium for research in mathematics education* (pp. 421-456). Reston, VA: National Council of Teachers of Mathematics.

Tuminaro, J., “A cognitive framework for analyzing and describing introductory students’ use and understanding of mathematics in physics”, University of Maryland, Doctor of Philosophy dissertation, (2004).

White Brahmia, S. (2019). Quantification and its importance to modeling in introductory physics. *European Journal of Physics*, 40(4), 044001. <https://doi.org/10.1088/1361-6404/ab1a5a>

White Brahmia, S., Olsho, A., Smith, T. A., Boudreaux, A. (2020). Framework for the natures of negativity in introductory physics. *Physical Review*, 16(1).
<https://doi.org/10.1103/physrevphyseducres.16.010120>

White Brahmia, S., Olsho, A., Smith, T. A., Boudreaux, A., Eaton, P., & Zimmerman, C. (2021). Physics Inventory of Quantitative Literacy: A tool for assessing mathematical reasoning in introductory physics. *Physical Review*, 17(2).
<https://doi.org/10.1103/physrevphyseducres.17.020129>

Vernaud, G (1998). A comprehensive theory of representation for mathematics education. *The Journal of Mathematical Behavior*, 17(2), 167–181. [https://doi.org/10.1016/s0364-0213\(99\)80057-3](https://doi.org/10.1016/s0364-0213(99)80057-3)

Zimmerman, C., Olsho, A., White Brahmia, S., Boudreaux, A., Smith, T. A., & Eaton, P. (2020). Exploring student facility with "goes like" reasoning in introductory physics. In 2020 *Physics Education Research Conference Proceedings*.
<https://doi.org/10.1119/perc.2020.pr.zimmerman>

Zimmerman, C., Olsho, A., Loverude, M., White Brahmia, S., (under review). Expert covariational reasoning resources in physics graphing tasks. *Physical Review*.

Contributed Papers

The Chain Rule in an Engineering Perspective

Imad Abou-Hayt¹ and Bettina Dahl²

¹Aalborg University, Denmark; imad@plan.aau.dk

²Aalborg University, Denmark; bdahls@plan.aau.dk

Introduction

The chain rule is one of the key concepts in calculus and forms a basic component of implicit differentiation, differentiation of inverse functions, and integration by substitution. Mathematically, the chain rule states that (Adams & Essex, 2010, p. 115):

If $f(u)$ is differentiable at $u = g(x)$, and $g(x)$ is differentiable at x , then the composite function $(f \circ g)(x) = f(g(x))$ is differentiable at x , and

$$(f \circ g)'(x) = f'(g(x)) \cdot g'(x)$$

The essence of the chain rule is that it explains the *compound ratio* among variables (Guicciardini, 2003). Thus, in Leibniz notation, the chain rule can be written as:

$$\frac{dy}{dx} = \frac{dy}{du} \cdot \frac{du}{dx}$$

Students' difficulties in understanding the chain rule have been reported in the research literature (e.g., Clark et al., 1997; Maharaj, 2013). Also, Tall (1993) found that “the Leibniz notation $\frac{dy}{dx}$ proves to be almost indispensable in the calculus. Yet it causes serious conceptual problems. Is it a fraction, or a single indivisible symbol? What is the relationship between dx in $\frac{dy}{dx}$ and the dx in $\int f(x)dx$? Can the du be cancelled in the equation $\frac{dy}{dx} = \frac{dy}{du} \cdot \frac{du}{dx}$?” (p. 19). Moreover, the formal proof of the chain rule seldom sheds light on its meaning, since it uses an algebraic trick (Cottrill, 1999).

Teaching the Chain Rule in an Engineering Context

Sazhin (1998) states that when engineering students learn mathematics, they need to know why this mathematics is essential for their engineering profession. Furthermore, equations need to be illustrated by examples from praxis, and the students need to have the necessary steps in algebraic manipulation highlighted. This is in line with the three worlds of mathematics stipulating, e.g., the importance of conceptual embodiment (Tall, 2013). Many studies (e.g., Uygur & Özdaş, 2007) have pointed out that teaching the chain rule should be done in real contexts. However, there have only been a few educational studies on incorporating real situations in teaching the chain rule (Park & Lee, 2016). Our paper attempts to fill that gap.

Our proposed teaching experiment consists of presenting a series of tasks aimed at facilitating the students' inquiry into the chain rule through an engineering context. The tasks will be integrated in the teaching of an engineering dynamics course in Spring 2023 for engineering students, enrolled in the study program “Sustainable Design”, at Aalborg University, Denmark. The first author of this paper is the instructor of the course. The evaluation and results of the teaching experiment will be the subject of a future research paper. We plan to analyze the students' answers to the tasks. We

will also interview some students to understand how they view the relevance of mathematics in an engineering course. In this paper, we will illustrate two tasks.

Task 1

Assume the carbon monoxide pollution in the air changes at the rate of 0.02 ppm (parts per million) for each person in a city whose population is growing at the rate of 1000 people per year. Find the rate at which the level of pollution is increasing with respect to time (Strauss et al., 2002, p. 138).

The purpose of this task is to allow the students to develop an *intuition* for the *multiplicative nature* of the chain rule and its composite elements and obtain an equation like

$$\frac{dL}{dt} = \frac{dL}{dP} \cdot \frac{dP}{dt}$$

where L is the level of pollution, P is the population, and t is time. Here, the Leibniz notation makes it visual to the students how $\frac{dL}{dt}$ is calculated “via” knowledge about how the population changes.

Referring back to Sazhin (1998) and Uygur & Özdaş (2007), we believe that a task like this which clearly involves an example as illustration from their engineering profession may but illustrate to the students why they need to learn about the chain rule, and they can work with the various algebraic parts of the chain rule and have the components explained and discussed.

Task 2

Given an illustration of a gear train in Figure 1. When the blue gear makes x turns, the black gear makes u turns and the red gear makes y turns. By counting the number of teeth of each gear,

- a) How are u and y related to x ?
- b) How many times does the red gear spin for every one spin of the blue gear?

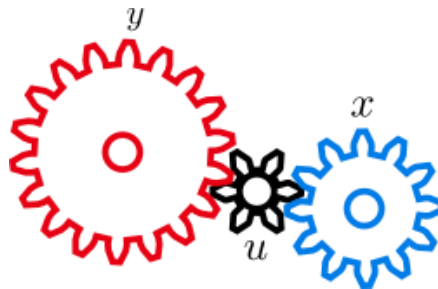

Figure 1: A gear train (drawn by the first author)

The purpose of this task is to help the students see both a composite function and the chain rule *in action*, by finding out that $u = 2x$ and $y = \frac{1}{3}u = \frac{2}{3}x$, and realizing that for every one rotation of the blue gear, the black gear will spin twice, and for each rotation of the black gear, the red will spin $\frac{1}{3}$ turn. In Leibniz notation, $\frac{du}{dx} = 2$ and $\frac{dy}{du} = \frac{1}{3}$ and thus,

$$\frac{dy}{dx} = \frac{dy}{du} \cdot \frac{du}{dx} = \frac{1}{3} \cdot 2 = \frac{2}{3}$$

Some functions can be written as composite functions in different ways and, to confirm that this will not change the final derivative, the students can examine what happens when the size of the

We wish to argue that mathematics for engineers should be taught in meaningful contexts and through well-designed tasks that allow the students to acquire genuine understanding of mathematical concepts, such as the limit of a function (Abou-Hayt et al., 2019) and the chain rule.

References

- Abou-Hayt, I., Dahl, B., & Rump, C. Ø. (2019). Teaching the limits of functions using The Theory of Didactical Situations and Problem-Based Learning. In B. V. Nagy, M. Murphy, H. Järvinen, & A. Kálmán (Eds.), *Proceedings, the 47th Conference of the International-Group for the European Society for Engineering Education* (pp. 58–69). Budapest, Hungary: SEFI.
- Adams, R. A., & Essex, C. (2010). *Calculus: a complete course* (7th ed.). Pearson Canada.
- Clark, J. M., Cordero, F., Cottrill, J., Czarnocha, B., DeVries, D. J., John, D. S., Tolia, G., & Vidakovic, D. (1997). Constructing a schema: The case of the chain rule? *The Journal of Mathematical Behavior*, 16(4), 345–364.
- Cottrill, J. F. (1999). *Students' understanding of the concept of chain rule in first year calculus and the relation to their understanding of composition of functions* [Doctoral dissertation, Purdue University].
- Guicciardini, N. (2003). Newton's method and Leibniz's calculus. In H. N. Jahnke (Ed.), *A History of Analysis* (Vol. 24, pp. 73–104). American Mathematical Society.
- Maharaj, A. (2013). An APOS analysis of natural science students' understanding of derivatives. *South African Journal of Education*, 33(1), 1–19.
- Park, J., & Lee, K. H. (2016). How can students generalize the chain rule? The roles of abduction in mathematical modeling. *Eurasia Journal of Mathematics, Science and Technology Education*, 12(9), 2331–2352.
- Sazhin, S. S. (1998). Teaching mathematics to engineering students. *International Journal of Engineering Education*, 14(2), 145–152.
- Skemp, R. R. (2006). Relational understanding and instrumental understanding. *Mathematics teaching in the Middle School*, 12(2), 88–95.
- Strauss, M. J., Bradley, G. L., & Smith, K. J. (2002). *Calculus* (3rd ed.). Prentice Hall.
- Tall, D. (1993). Students' difficulties in calculus. *Proceedings of Working Group 3 on Students' Difficulties in Calculus: ICME7* (pp. 13–28). University of Warwick, Québec.
- Tall, D. (2013). *How humans learn to think mathematically: Exploring the three worlds of mathematics*. Cambridge University Press.
- Thomas, G. B., Weir, M. D., Hass, J., Heil, C., & Behn, A. (2010). *Thomas' calculus* (12th ed.). Pearson.
- Uygur, T., & Özdaş, A. (2007). The effect of arrow diagrams on achievement in applying the chain rule. *PRIMUS: Problems, Resources, and Issues in Mathematics Undergraduate Studies*, 17(2), 131–147.

Students' understanding of Laplacian and gradient in mathematics and physics contexts

Maria Al Dehaybes⁽¹⁾, Johan Deprez⁽¹⁾, Paul van Kampen⁽²⁾ and Mieke De Cock⁽¹⁾,

⁽¹⁾KU Leuven, Belgium; maria.aldehaybes@kuleuven.be; johan.deprez@kuleuven.be; mieke.decock@kuleuven.be

⁽²⁾Dublin City University, Ireland; paul.van.kampen@dcu.ie

Abstract: In this study, we investigate undergraduate students' understanding of two multivariable calculus concepts, the gradient and the Laplacian, using open ended paper-and-pencil tests. We study students' reasoning in two contexts: math and physics, and in different graphical representations of multivariable functions: 3D graphs and contour plots for the gradient, and 3D graphs and vector plots for the Laplacian. Findings reveal that students often have similar difficulties in both contexts, but they have a context-specific preference for representing their answers and demonstrate varying reasoning competencies for the same concept in different answer representations. Observed difficulties for each concept will be addressed.

Introduction

The interplay between math and physics has many aspects. The two disciplines become more interconnected in advanced physics courses, where the application of math concepts is significantly different from that in math courses, thus creating challenges for students (Karam et al., 2019). Students' difficulties with mathematics in physics have been previously investigated on topics such as student understanding of vector calculus in the context of electromagnetism (Bollen et al., 2017) and partial derivatives in the context of the one-dimensional heat equation (Van den Eynde et al., 2022), however studies investigating students' understanding of multivariable calculus concepts in physics are limited. Expanding the knowledge on students' challenges with concepts like gradient, Laplacian, and multivariable functions in a physics context can shape instruction to support students in utilizing the interplay of the two disciplines. Some studies have considered multivariable calculus concepts involving functions of two variables (Martínez-Planell, & Trigueros, 2021) including gradient (Moreno-Arotzena et al., 2021) in a math context. In this paper, we investigate the students' difficulties with the concepts of gradient and Laplacian and compare their reasoning strategies in a math context and in a physics context.

Methods

To investigate students' understanding, we designed conceptual questions within a graphical setting. Students were asked to interpret a graphical representation and to explain their answers. Four questions per concept were developed based on two facets: (1) context (math or physics) and (2) the graphical representation of the multivariable function used in the problem statement (graph or contour plot for gradient, and graph or gradient vector field for Laplacian). Figure 1 shows the graph (a) and the contour plot (b) of the function in the problem statement of the gradient question in a physics context. The questions were validated through individual "think-aloud" interviews and

were administered as paper-and-pencil tests to 185 first-year students enrolled in calculus based introductory physics courses and multivariable calculus courses. Students gave individual responses in an exam-like setting.

Each student solved a gradient question and a Laplacian question either in math or physics context and in only one representation. In the gradient question, students were asked to choose from four possible gradient vector field plots the one that corresponds to the 3D graph or contour plot. In the Laplacian question, students were asked to indicate whether the Laplacian is zero or non-zero at a given point. In both questions, students were then asked to explain their choice using the given graphical representation and to give a general interpretation of the concept. Thematic analysis was used to categorize student answers. The coding schemes were built bottom up from the data.

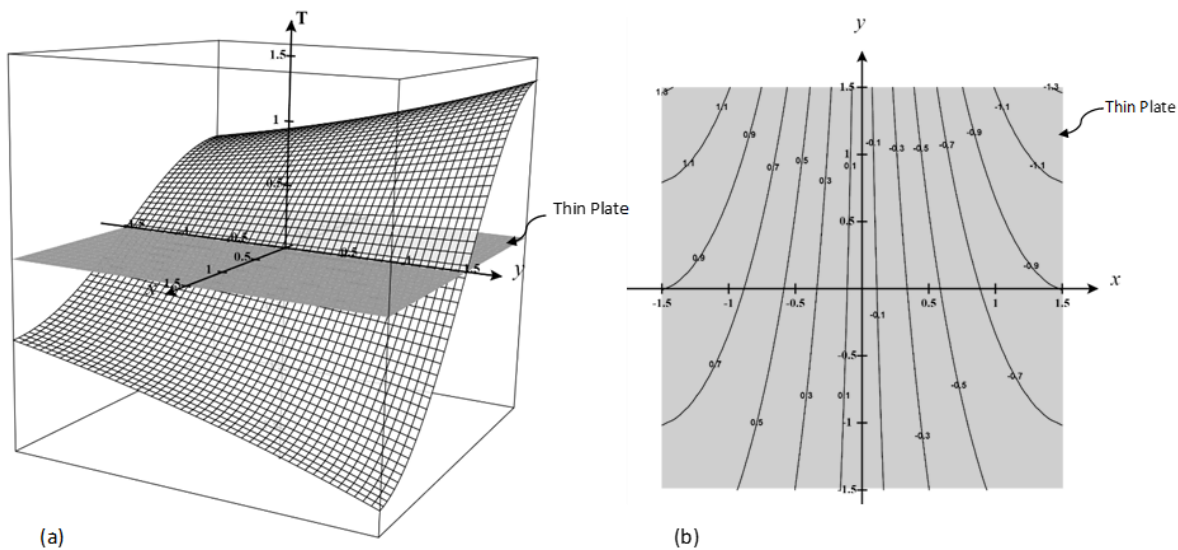

Figure 1: Graph (a) and contour plot (b) of a function of two independent variables assigned to students in the physics context. Students were given only one of the representations.

Findings

To describe the students' understanding, the emergent codes were categorized into themes. In what follows we focus on student difficulties within three themes: the graphical theme, which includes codes with a graphical reference such as steepness; the vector theme, which includes codes referring to the gradient vector nature or its representation; the semantic synonym theme, which includes codes referring to an explicit or implicit linguistic meaning of the concept such as rate of change.

Gradient: Steepest incline at a point in 3D

When linking the steepness at a point on the graph to the vector nature of the gradient, students' answers lacked specificity. Almost a quarter of the students did not differentiate between steepness and steepest incline in their explanations. For example, students stated that the direction of the gradient vector follows the slope while ignoring that at a point on the graph of a function of two independent variables there could be multiple ascends of different slopes and the gradient vector follows the steepest ascend. We argue that such answers adopt a two-dimensional approach for a function of one independent variable where there is only one slope in a point. This leads us to

question whether these students can extend their 2D understanding of steepness at a point (function of one variable) to three dimensions in the case of a function of two independent variables. Taking this a step further, 7% (7 out of 96) of students referred to the global maximum when linking the steepness on a graph to the gradient vector field where the highest point instead of the steepest slope was taken as a reference for the direction of the gradient vector at a point.

In the contour plot questions, 13% (12 out of 92) of students correlated the magnitude of the gradient vector at a point incorrectly with the spatial distance between adjacent level curves. These students associated a wider spacing between two consecutive level curves with a longer gradient vector, and vice versa. In addition, almost 25% (24 out of 92) of students who answered the contour plot gradient question chose the gradient vector field where the vectors were tangent to the level curves instead of perpendicular. In their explanations, almost 30% (7 out of 24) of these students related the steepness of the tangent to the level curves to the length and direction of the gradient vector. This not only shows that students have a difficulty understanding a contour plot, but it also confirms our interpretation of their difficulty with extending the concept of steepness to three dimensions 3D.

Gradient-Laplacian Equivalency

Students struggled to represent the Laplacian graphically. 43% (54 out of 124) of students associated a zero value for the Laplacian with the presence of an extremum at a point on the 3D graph or with the absence of a vector at a point on a gradient vector field. We interpret this as students seeing a graphical equivalency between the gradient and the Laplacian specifically when they describe the magnitude.

Most students described the Laplacian with the same terminology that other students used for the gradient. Terms like “change” and “biggest/highest change” were used similarly (and incorrectly) to describe both concepts. Symbolically, some students wrote the algebraic expression of the gradient when they were asked about the Laplacian, or expressed the Laplacian in another incorrect vector representation, which further supports our interpretation.

49% (29 out of 59) of students who solved the Laplacian question in the gradient vector field representation did not interpret the divergence. In their answers, students associated a zero value for the gradient at a given point with a zero value for the divergence of the gradient or the Laplacian at that point. A lack of comments about the divergence operator’s effect on the gradient vector field in the students’ answers strengthens our interpretation that many students see gradient and Laplacian as equivalent. While students might know that Laplacian and gradient are two distinct concepts, they do not seem capable of establishing a clear distinction in their explanations and interpretations. At introductory physics level, similar difficulties have been observed between velocity and acceleration, and electric field and potential.

Context

The observed difficulties explained were consistent across the math and physics contexts. However, students’ use of representations in their own explanation differed between contexts. Overall, students were more likely to use semantic synonyms in a physics context for both concepts. For the

gradient, in the physics context, students typically linked the gradient vector at a point to a semantic synonym such as “highest/biggest change”. In the math context, they linked it more often to a graphical aspect such as the proximity of level curves. For the Laplacian, students in general showed a tendency to use semantic synonym for their answers in a physics context.

Students performed worse when they interpreted both concepts using semantic synonyms. In contrast, they performed better in the Laplacian question when they answered algebraically with formulas and expressions, and better in the gradient question when their answers had a graphical or vector nature reference.

Implications

The difficulties revealed in this work contribute to the knowledge on students’ understanding of multivariable calculus concepts in physics and math contexts. It was shown that students have difficulties in representing the concepts using graphical and semantic synonyms references in both contexts. This highlights that students need more support in their conceptual understanding which, if improved, gives them access to the conceptual knowledge within different representations of the same concept and therefore be able to connect the abstraction represented symbolically to contextualized knowledge. This could possibly make the combination of math and physics within more advanced topics like the two-dimensional heat equation less challenging for the students.

References

- Bollen, L., van Kampen, P., & De Cock, M. (2015). Students’ difficulties with vector calculus in Electrodynamics. *Physical Review Special Topics - Physics Education Research*, 11, 020129. <https://doi.org/10.1103/physrevstper.11.020129>
- Karam, R., Uhden, O., & Höttecke, D. (2019). The “math as prerequisite” illusion: Historical considerations and implications for physics teaching. *Mathematics in Physics Education*, 37–52. https://doi.org/10.1007/978-3-030-04627-9_2
- Martínez-Planell, R., & Trigueros, M. (2021). Multivariable calculus results in different countries. *ZDM – Mathematics Education*, 53(3), 695–707. <https://doi.org/10.1007/s11858-021-01233-6>
- Moreno-Arotzena, O., Pombar-Hospitaler, I., & Barragués, J. I. (2020). University student understanding of the gradient of a function of two variables: An approach from the perspective of the theory of semiotic representation registers. *Educational Studies in Mathematics*, 106(1), 65–89. <https://doi.org/10.1007/s10649-020-09994-9>
- Van den Eynde, S., Goedhart, M., Deprez, J., & De Cock, M. (2022). Role of graphs in blending physical and mathematical meaning of partial derivatives in the context of the heat equation. *International Journal of Science and Mathematics Education*, 21(1), 25–47. <https://doi.org/10.1007/s10763-021-10237-3>

Multivariable integrals for physicists – a concept or a tool?

Matija Bašić¹, Željka Milin Šipuš¹

¹University of Zagreb, Faculty of Science, Department of Mathematics, Zagreb, Croatia;

mbasic@math.hr milin@math.hr

Introduction

Multivariable calculus is a very large and important branch of mathematics, which entails different results of both single variable calculus and linear algebra, and intertwined with basic aspects of topology, differential equations and differential geometry. Moreover, it is fundamental to physics, from classical mechanics and electrodynamics to quantum theory and relativity. Historically, the development of mathematics and physics has been closely related, but despite these relationships, it is a common knowledge that “non-specialist students encounter difficulties with mathematics” (González-Martín, Gueudet, Barquero, & Romo-Vázquez, 2021). Regarding physics, there is some evidence on differences described by means of the theoretical framework of the Anthropological Theory of the Didactic, thus e.g. Hitier & González-Martín (2022) compare students’ knowledge concerning the concept of derivative in physics (mechanics) and mathematics, and difficulties that students meet when transferring from one field to another. In this paper we focus on the role of integrals of multivariable functions in the (undergraduate) study program of physics. Each such program has its own institutional specificities, some focus more on the experimental side of physics, while others are more theoretically inclined or combined with the study of mathematics. The position of multivariable calculus may hence be quite different. On the one hand, there could be a separate course on multivariable calculus which develops the theory systematically and thoroughly, sometimes taught by a mathematician. Such approach might lead to compartmentalization and weak connections of the taught knowledge to its applications in other courses. In other programs, where there is no such course, the many different pieces of multivariable calculus are taught within other (physics) courses.

Motivation, research question and theoretical framework

This paper is part of an ongoing research about curves and surfaces, as main geometrical objects in multivariable calculus. We formulate the study in the language of the Anthropological Theory of the Didactic (ATD) (Chevallard, 1991), which describes (mathematical) knowledge in terms of praxeologies as the set consisting of *types of tasks*, *techniques* needed to carry them out, *technologies* that justify the techniques, and *theories* that sustain technologies. Praxeologies describing a piece of knowledge form a *reference epistemological model* (REM), a relative and hypothetical model set by a researcher, established depending “on the didactic problem approached and the phenomena one wishes to study” (Bosch, Gascon, & Trigueros, 2017, p. 43). ATD further emphasizes institutional construction of knowledge, which in our case would concern two institutions – institution of mathematical courses and institution of physics courses, further analyzed in their relationship. For undergraduate courses on multivariable calculus carried out for students of mathematics, REM on geometrical aspects that are intrinsic to the calculation of multivariable integrals was developed by Bašić & Milin Šipuš (2022). Our intention in this study is to delimit the role of multivariable integrals in the (undergraduate) study program of physics and

therefore we question: How do the perspectives of mathematics and physics students differ with respect to multivariable calculus/integrals? Which praxeologies of multivariable integrals are not present in the physics program and how is that compensated?

Context of the study

We investigate the situation at the Department of Physics at the Faculty of Science in Zagreb, Croatia. There was only an elective course *Mathematical analysis in space*, in which the mathematical formalism of multidimensional calculus was introduced and presented, but even this course was recently taken out of the program. Hence, we consider a study program in which the multivariable calculus is taught by physicists throughout many different courses.

We analyzed the written lecture notes for the course Classical electrodynamics (CED), taught in the third year. The students report that this is the most difficult course for them so far. Certainly, one of the reasons is that it is the most demanding course in terms of needed mathematical competencies, some of which not developed anywhere else in the study program. To investigate the differences between the use of multivariable integrals among the physicists and mathematicians, we have compared the course materials with the earlier mentioned REM and we interviewed the teaching assistant of CED. The purpose of the interview was to gather insights into practices of the institution and the experience of the students as they encounter the mathematical problems related to multivariable integrals. Interview was performed by the first author and lasted for about 30 minutes. The interview was structured by the following questions: In which courses students encounter multivariable integration? Is the concept of Riemann integration in multiple dimensions discussed? In which way do the students learn how to approach integration problems and choose appropriate coordinates? Which coordinate systems are used and how are nonstandard changes of variables treated? How do students use and interpret Gauss and Stokes theorem? Are they presented as instances of the same formalism? What are, in your opinion, differences among mathematicians' and physicists' understanding of multivariable integrals?

Results and discussion

The lecture notes for the course CED are written in a very pedagogical style, introducing mathematical and physical concepts gradually, and supplemented with appendices on mathematical theory. They are based on the well-known and widely used textbooks. As the author says: "the more advanced mathematical concepts are introduced later during the course to alleviate the complexity of the subject". The notes comprise of more than 380 pages, and start with the "Panoramic view of electromagnetism". We focus on the chapters on electrostatics, magnetostatics and electrodynamics – covering the four Maxwell equations, in both the differential and integral form. Integration techniques are not treated separately. The appendix on coordinate systems begins with the overview of cylindrical and spherical coordinates, expressing the important tensors in these coordinates, and then continues with mentioning the formulas for less frequent coordinates: ellipsoidal, bispherical and toroidal. We consider also solved exercises and exam questions, from which we present one in Figure 1. It shows the typical situation described in geometric terms, in which it is clear which coordinate system should be used. The situation carries a lot of symmetry

and the students are expected to use the formulas given in the lectures. The computation is lengthy, but if the coordinates are plugged in carefully, it turns into a simple integral of one variable.

A homogenous (hollow) sphere of radius R carries charge Q . Determine the force with which the remainder of the sphere acts on the sphere cap of the polar angle α .

Source of the image: https://commons.wikimedia.org/wiki/File:Spherical_cap.gif

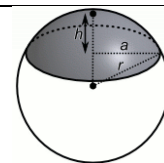

Figure 1: Typical task involving spherical coordinates in Classical electrodynamics

From the interview we learn that the use of cylindrical and spherical coordinate systems are taught from the first year ‘on the go’ in the scope of various courses, e.g. General physics, Classical mechanics etc. We may notice that the first encounter - find the center of the mass, the inertial moments etc. - is similar to the problems that are given in the mathematics courses. These examples take advantage of the presence of symmetry.

There are three coordinate systems used by physicists: Cartesian, cylindrical and spherical. Other coordinate transformations (e.g. rotating the plane for 45 degrees, $(x, y) \mapsto (x + y, x - y)$) are familiar only to a few students and shown as peculiarities. The students learn how to use them situationally – one uses the cylindrical system for a cylinder or a long rod, while the spherical system for a sphere or a point source. After making a choice of an appropriate coordinate system, the integration problems are usually such that the iterated integral has separated variables. For the problems that are not posed in such a way, the students are given the instruction in form a rule they are advised to follow: “in spherical coordinates integrate in the order phi-theta-r”. This also shows that the problems are suited for this kind of iterated integration. As claimed by the teaching assistant, a student can graduate from the physics program, using only iterated single variable integrals. We can conclude that for the part on Riemann integration, the theoretical part of the (regional) praxeologies are not presented. Fubini’s theorem is used implicitly as the integration over geometric objects is directly reduced to parametrizations and iterated integrals. So, as opposed to mathematics courses, the physics students only need to master one type of conversion between representations and algebraic equations of geometric objects are not used. Moreover, the practical block rarely considers objects other than rods, cylinders, points and spheres. The second order surfaces (e.g. paraboloids and hyperboloids) and the intersections of multiple such surfaces is not considered. Hence, the geometric praxeologies related to relative position of the surfaces are not needed or present.

We may notice some similar phenomena for the theory and main theorems concerning surface integrals. For a physics student at the level of classical electrodynamics, Gauss’ and Stokes’ theorem are quite different results, representing constraint equations and evolution equations. Teacher points out that it is not of such great importance that they may be seen as consequences of the same formalism. Moreover, these results are considered by physicists as “technical tools that enable practical considerations and simplifications of integrals, similar to the technique of partial integration, and are used mechanically”. These theorems are deduced using a simplified argumentation that is based on two main ideas: curves and surfaces are represented as unions of linear objects (segments or rectangles) and then the results are deduced by passing to the limit (considering ‘inifinitesimal’ partition of the geometric object). For a physicist “this argument is

acceptable because of its plausibility and accordance with intuition about space and geometry”. The issue for students appears as the concepts of surface orientation and differential forms are not developed, so the rules for changing the sign in the surface integral (e.g. $dy \wedge dx = -dx \wedge dy$ and $dx^2 = 0$) remain vague and unexplained. In general, the solutions of equations should in addition consider ‘natural’ boundary conditions, e.g. they vanish at infinity (as fast as needed).

As the main difference, the teacher emphasizes that the approach of mathematicians is more systematic and complete, developing the concepts gradually, while the physicists’ approach is more connected interpretation, using integrals as tools and obtaining results in a limited number of situations of interest. As to the views on the specific program, the institution withholds the tension between theoretical and experimental physicists, ones inclined to talk more about ‘tensors’ and the other about ‘sensors’.

We conclude that that there is no clear answer to the question of more efficient mathematics education of physicists, but that it is clear that the knowledge to be taught requires a much deeper didactic transposition that will provide at least some parts of the technologies in order for the students to feel confident about understanding the procedures they follow and to carefully select the techniques and types of tasks that are relevant to most typical physical situations. The students might be encouraged to pursue deepening their knowledge on their own or through additional (elective) courses, depending on their future academic perspectives. In the end, there is never a perfect balance, but we might certainly hope that the multivariable calculus for physicists will remain being taught either by mathematicians that are aware of the true needs of the physics program, or a slightly theoretically inclined physicist that is enthusiastic about the systematic development of mathematical knowledge.

References

- Bašić, M., & Milin Šipuš Ž. (2022). Geometrical Reasoning in the Teaching and Learning of Integrals of Multivariable Functions, *International Journal of Research in Undergraduate Mathematics Education* 8(3), [https:// doi. org/10.1007/s40753-022-00179-8](https://doi.org/10.1007/s40753-022-00179-8)
- Bosch, M., Gascon, J., & Trigueros, M. (2017). Dialogue between theories interpreted as research praxeologies: The case of APOS and the ATD. *Educational Studies in Mathematics*, 95, 39–52. [https:// doi. org/ 10. 1007/ s10649- 016- 9734-3](https://doi.org/10.1007/s10649-016-9734-3)
- Chevallard, Y. (1991). La transposition didactique – Du savoir savant au savoir enseigné. (2e) *La Pensée sauvage*, Grenoble.
- González-Martín, A., Gueudet, G., Barquero, B., & Romo-Vázquez, A. (2021). Mathematics and other disciplines, and the role of modelling, Advances and challenges, Chapter in the book Viviane Durand-Guerrier, Reinhard Hochmuth, Elena Nardi, Carl Winsløw (Eds). Research and Development in University Mathematics Education, <https://doi.org/10.4324/9780429346859>
- Hitier, M., & González-Martín, A. (2022). ”It all depends on the sign of the derivative”: A praxeological analysis of the use of the derivative in similar tasks in mathematics and mechanics. Twelfth Congress of the European Society for Research in Mathematics Education (CERME12), Feb 2022, Bozen-Bolzano, Italy. hal-03750626f

Bridging the Gap Between the Biology and Calculus by Teaching Modeling

Steve Bennoun¹, Alan Garfinkel² and Eric Deeds³

¹University of California Los Angeles, United States; bennoun@ucla.edu

²University of California Los Angeles, United States; agarfinkel@mednet.ucla.edu

³University of California Los Angeles, United States; deeds@ucla.edu

In recent decades the use of mathematics in biology and the life sciences has both become more prevalent and has earned new respect (May, 2004). In 2009 the National Research Council (NRC) called for a “New Biology” that would combine the different sub-fields of biology “through the unifying languages of mathematics [and] modeling” (2009, p. 4). This evolution of the biological sciences has been accompanied by high profile reports calling for the reform of mathematics instruction for biology and life sciences students (e.g., NRC, 2003; American Association for the Advancement of Science [AAAS], 2009). Echoing these calls from professional associations, the Association of American Medical Colleges issued a joint report with the Howard Hughes Medical Institute (AAMC, 2009) listing the competencies that undergraduate students should master when entering medical school. Interestingly, these skills include quantifying and interpreting changes in dynamical systems as well as using mathematical models to make inferences about natural phenomena, but not computing derivatives by hand nor proving theorems (AAMC, 2009).

Recognizing the need for reform, the UCLA Life Sciences Division decided in 2013 to create a new “Calculus for Life Sciences” course. This course would focus on the mathematical concepts truly used by biologists. Moreover, it would genuinely interweave the biology and mathematics. In the rest of this paper, we start by identifying mathematical concepts that are important in biology and can be studied in a calculus course. We then describe the content of the new Calculus for Life Sciences course developed at UCLA and explain the approach taken to teach these concepts. We finish by briefly describing the impact of the course and some concluding remarks.

Mathematical Concepts Used in Today’s Biology

When designing the new curriculum, the first point that quickly became clear was the necessity to focus on modeling and dynamical systems. The AAAS’s report (2009) states that “studying biological dynamics requires a greater emphasis on modeling [...] than ever before” (p. 3). The same report lists the “ability to use modeling and simulation” (p. 14) as a core competency for undergraduate biology students. In the same vein, the AAMC states that pre-medical students should be able to “make inferences about natural phenomena using mathematical models” (2009, p. 23) as well as “quantify and interpret changes in dynamical systems” (2009, p. 24). To a mathematician, these recommendations may imply that a calculus course for biologists should quickly move from the definitions of derivative and integral to focus on solving differential equations. Such a course would review the different types of differential equations and the techniques to solve them. However, this would not be taking the needs and practices of biologists

into account. Indeed, the NRC specifies that while students should study mathematical models that involve ordinary differential equations, these equations should be “made tractable and understandable via Euler’s method without any formal course in differential equations” (2003, p. 172). The same report underlines that “the emphasis should not be on the methods per se, but rather on how the methods elucidate the biology” (2003, p. 170). The reliance on numerical methods to solve differential equations comes from the fact that almost all differential equations arising in biology are not analytically solvable and thus do not have closed form solutions, making the study of techniques to solve such equations by hand pointless. It also highlights that for biologists, differential equations are really a tool that describes how a system changes with time. This tool is used to make predictions about the future evolution of a system and to gain a new understanding of the biology. In other words, it is the biological meaning of the equations (and of their solutions) that is important, not the equations per se. This perspective is shared by the AAMC when it states that pre-medical students should be able to “describe the basic characteristics of models” (2009, p. 24) and “predict short- and long-term growth of populations” (2009, p. 24).

A very important aspect in biology is to determine the qualitative, rather than quantitative, nature of biological systems’s dynamics. For example, when studying predator-prey populations, a fundamental question is not so much towards which precise number each population will tend but rather whether the populations will tend to specific numbers or whether they will oscillate. Another example is whether a cell has the capacity to shift its production of a protein from low to high levels (known as a “biological switch”) or if on the contrary the protein production will always tend to a unique level. These questions about qualitative changes are of great importance for biologists.

Content of the New Course

The approach in our course is to start with important questions about biological systems and then develop the mathematical concepts necessary to answer these questions. We begin the course by having students consider a simple predator-prey system (called the “shark-tuna” system) and ask them to predict the future evolution of the two populations. It becomes quickly clear that to make sensible predictions one needs a mathematical model. The next step is thus to learn how to write models for dynamical systems. With this approach it is the biology that genuinely motivates the introduction and study of mathematical concepts. Moreover, we can underline from the beginning the importance of focusing on the biological meaning of the equations of a model (and of the other mathematical concepts we introduce) rather than seeing them as abstract mathematical objects.

Building Models

We begin by having students learn how to write mathematical models. To this end students learn that equations describe how a system changes with time. Since at this point in the course we have not yet introduced the concept of derivative, the differential equations of a model are presented and thought of as “change equations”. For example, in the shark-tuna model, where T is the number of tuna and S the number of shark, we think of T' as the change in the number of tuna and of S' as the change in the number of shark. We learn that equations are composed of terms representing inflows and outflows (what makes the variable “go up” or “go down”). For instance, we learn that the shark’s birth rate is $b_S S$ (an inflow) and its death rate $d_S S$ (an outflow). Importantly we learn why a

shark-meets-tuna encounter is modeled by cST . This idea of modeling an encounter by multiplying the variables together is then used in many other models we study such as epidemiological models (where a susceptible individual encounters an infected individual) or chemical reaction models (where a sodium molecule encounters a chloride molecule).

The equations of a model are treated geometrically. For any time t the values of the variables can be represented as a point in the state space, which is the space containing all possible values of the variables. To each point in the state space, there is a corresponding “change vector” given by the change equations, in other words we have a vector field. For example, in the shark-tuna model to each point (T, S) corresponds a change vector (T', S') . We then learn that through each point in the state space passes a trajectory (the solution of the differential equation) and that change vectors provide the direction of the trajectory. Finally, we study Euler’s method as a way to find the (approximate) trajectory starting at a given initial condition. When looking at trajectories we underline what they correspond to biologically (e.g., a population increasing or decreasing).

Derivatives and Integrals

At this point in the course, we introduce the concept of derivative. We define the derivative as the instantaneous rate of change of a function. We show how the derivative is equivalent to the slope of the tangent line to the function. We then put a great emphasis on thinking of the derivative as (the slope of) the linear approximation to the function at a point. The reason for this emphasis is that it naturally leads to the linear stability analysis of equilibrium points. While we review differentiation rules and verify them with some examples, we do not prove them. We introduce integrals as the limit of the Riemann sum and focus on the idea that the integral represents “the area under the curve” of a function. We study the Fundamental Theorem of Calculus as a way to connect the notions of derivative and integral. We do not study techniques of integration.

Long-Term Behaviors of Systems

After having formally introduced derivatives and integrals, we tackle the fundamental question of the long-term behavior of a system. Together with the study of qualitative change (see below), this is really the central part of the course. We investigate biologically-important questions such as: Does a population need to go above a certain threshold to survive in the long term? Will two competing populations coexist in the long run or will one of them go extinct? Does a cell possess a *biological switch*, which is the ability to “turn on or off” the production of a protein? To answer these questions, we introduce the concepts of equilibrium point and stability. Students learn to determine the stability of equilibrium points using linear stability analysis in one dimension and nullclines in two dimensions. Crucially, we learn how to translate biological questions in terms of equilibrium points and trajectories, and then interpret insights in biological terms.

Bifurcations and Oscillations

Studying biological systems’ long-term behaviors naturally leads us to consider the all-important notion of *qualitative change*. Mathematically, a qualitative change is a bifurcation, which is a change in the number of equilibrium points or in their stability. Studying bifurcations using bifurcation diagrams enables us to explain important biological phenomena such as the sudden drop

of vegetation cover in shallow lakes (Scheffer et al., 2001). Our study of bifurcations includes the notion of Hopf bifurcation, which corresponds to the emergence or disappearance of oscillations in a system. Oscillatory processes are widespread in biology and medicine, simple examples include body temperature or blood glucose level. By studying Hopf bifurcations we can explain why the level of certain hormones oscillate with time or why a heart failure can cause a patient to have the abnormal oscillatory breathing pattern called Cheyne-Stokes respiration.

Impact on Success in Subsequent Courses and Concluding Remarks

One question that naturally arises with this new curriculum is whether students are well prepared for subsequent science courses. Using multi-linear regression models, Sanders O’Leary et al. (2021) observed that taking the new Calculus for Life Sciences course compared to the “traditional” Calculus for Life Sciences course increased predicted grades in subsequent chemistry, life sciences and physics courses.

Our experience at UCLA provides an example of how one can revise the curriculum of a calculus course in order to make it more strongly aligned with how biologists understand and use calculus concepts. One question that arises is the impact of this curriculum on student learning. We argue that focusing on dynamical systems and bifurcation theory provides a very fruitful framework to deeply connect biology and calculus. Using the concepts of trajectory and vector field, we are able to take a modern approach that corresponds to the practice in biology.

References

- American Association for the Advancement of Science. (2009). *Vision and change in undergraduate biology education: A call to action*. <https://live-visionandchange.pantheonsite.io/wp-content/uploads/2013/11/aaas-VISchange-web1113.pdf>
- Association of American Medical Colleges and Howard Hughes Medical Institute. (2009). *Scientific foundations for future physicians*. Association of American Medical Colleges. <https://store.aamc.org/scientific-foundations-for-future-physicians-pdf.html>
- May, R. M. (2004). Uses and abuses of mathematics in biology. *Science*, 303(5659), 790–793. <https://doi.org/10.1126/science.1094442>
- National Research Council. (2003). *BIO2010: Transforming undergraduate education for future research biologists*. The National Academies Press. <https://doi.org/10.17226/10497>
- National Research Council. (2009). *A new biology for the 21st century*. The National Academies Press. <https://doi.org/10.17226/12764>.
- Sanders O’Leary, E., Sayson, H. W., Shapiro, C., Garfinkel, A., Conley, W. J., Levis-Fitzgerald, M., Eagan, M. K., & Van Valkenburgh, B. (2021). Reimagining the Introductory Math Curriculum for Life Sciences Students. *CBE—Life Sciences Education*, 20(4). <https://doi.org/10.1187/cbe.20-11-0252>
- Scheffer, M., Carpenter, S., Foley, J. A., Folke, C., & Walker, B. (2001). Catastrophic shifts in ecosystems. *Nature*, 413(6856), 591–596. <https://doi.org/10.1038/35098000>

Difficulties of students with the articulation of knowledge from physical sciences and mathematics

Rahma Bouguerra

Virtual University, ISEFC, Tunis, Tunisia; rahmabouguerra@gmail.com;

INTRODUCTION AND THEORETICAL SECTION

This research is a result of an investigation into the difficulties students have in learning the derivative concept and working on unveiling several origins that hinder the process of conceptualization. We identified the constraints that prevent them from understanding the concept definition of a derivative at a point and from having adequate concept images of this complex notion. These difficulties have several origins, they are of epistemological origin, they originate from the mathematical objects themselves and from the ways of presenting them in textbooks. In this article, we provide a glimpse into how this concept is introduced in textbook and how students articulate their knowledge of mathematics and physical sciences when confronted with it. The most prominent claim around which our study revolves is concerned with the fact that: the interpretation of the derivative as an instantaneous rate of change to the students plays an essential role in strengthening their concept images. In the Tunisian context, the concept of derivative is introduced as an instantaneous speed for the first time in the third year of secondary school (17-18 years). This concept is introduced by the instantaneous speed which is already known by students in courses of physics. Indeed, there is no doubt that this approach is closely related to the subject being taught (i.e. derivative concept) but is there really nothing that prevents students from understanding it through this approach? From this perspective, we wonder whether this approach is sufficient to make a strong conception for the students or not? Do they really properly understand the meaning of the instantaneous speed? Are they really aware of the relationship between the rate of change and the derivative at a point? Do they know that derivative is an instantaneous rate of change? Thought on the epistemological aspects of the derivative concept and the various notions associated with it raises a number of inquiries that must be addressed, including the ways of presenting this concept in textbooks as well as the students' conceptualizations of the derivative and the notions related to it. Indeed, we wanted to analyse institution choices in introducing derivative at a point and their relationship to students' understanding of derivatives. Therefore, we relied on Praxeology (Chevallard, 1999) and images frame (Tall & Vinner, 1981) to model derivative institutional organisation into several mathematical activities and analyse concept images that students have in regards to the notion of the derivative and some other related terms. By using these frames, we know the different difficulties learners have and the origins of these difficulties occurring when learning this concept.

EMPIRICAL SECTION

When launching our journey into reviewing the official program text of Mathematics for the third-year secondary school, we found that one of the primary guidelines in the curriculum is for students to grasp that the derivative at a point is the slope of the tangent to the curve. There is also a note stating that the instantaneous velocity notion could be used as an example for

introducing the derivative. The derivative chapter of the official mathematics textbook begins with two activities concerning the concepts of speed and instantaneous speed, both of which contain the formal definitions of these notions as previously defined in physics courses: average speed is defined as a distance divided by time, and instantaneous speed is defined as the limit of the average speed. These concepts are considered simple calculations rather than specific instances of the rate of change. In first-year secondary school physics textbooks, the average speed is introduced by the notion of ‘rapidity’ to compare the speed of two movements, by identifying as follows: “the rapidity notion is characterized by a quantity depending on the length of the path traveled and the duration of the path; this quantity is called average speed. Then the average speed of a mobile is equal to the ‘quotient’ of the distance ‘d’ travelled by the mobile by the duration ‘t’ of the journey, $V_{\text{moy}} = d/t$ ”. Indeed, these first two activities are followed by an activity related to the geometric interpretation of the derivative concept. These three successive activities are followed by the definition of the derivative concept and the equation of the tangent to the curve as a consequence of the differentiability of the function at a point without any further explanation. It should be noted here that the introduction of derivative does not focus on precise or formal definition of the rate of change, only its algebraic expression is used to talk about derivative notion. It is worth mentioning here that the definition of the rate of change is not found in all textbooks (mathematics and physics) of each grade level of high school. Only the algebraic expression of this concept is indicated whenever it must be used without presenting it as an independent concept. For instance, in the chapter on the derivative of a function, one exercise touches upon the notions of production rate and instantaneous rate of production, giving their definitions to calculate them and determine the behavior of the function. Furthermore, according to the praxeological analysis (table 1), mathematical activities related to the derivative in the Tunisian curriculum mostly entail algebraic and algorithmic activities, rule applications, or well-known techniques. As a result, the research demonstrates that the institution's purpose is to assist students in learning algebraic abilities with the derivative concept.

Type of task T1	Calculate the derivative of a given function f in a given point 'a'
Type of task T2	Determine the equation of the tangent line to a function in a point 'a'
Type of task T3	Calculate the limit of the function f at a point a, by using the derivative at a point 'a' of a function that we have to determine.
Type of task T4	Draw the tangent.
Type of task T5	Determine the points on a curve where the tangent T is parallel to another line noted.
Type of task T6	Deduce that the tangent line T to the curve of function 'f' and the tangent T' to the curve of function 'g' are perpendicular lines.
Type of task T7	Demonstrate that the tangent T to the curve C and the tangent T' to the curve C', at the point $x=a$, are parallel.
Type of task T8	Demonstrate that the tangents to the curve C respectively at the points A and B are parallel.
Type of task T9	Demonstrate that C is above T (or C is in below T).
Type of task T10	Estimate the value of a function

Table 1: all the type of tasks, which are in work in the curriculum

Obviously, the lack of familiarity with the notion of the rate of change in physics and mathematics courses would be the gap and the constraint that prevents students from understanding the derivative concept. The instantaneous speed is considered a direct application of the derivative concept, both of which are defined abstractly. Therefore, we anticipated that students' difficulties would lie in the articulation of knowledge from physical sciences and from mathematics.

At a later stage, to gather complement information illustrating the problem, we conducted an interview (with 30 students from Pilote School Kairouan) and a questionnaire highlighting students' images (the questionnaire was completed by 166 students of the third year of

secondary school from various secondary schools) about derivative notion. The structure of questionnaire is far from numerical and direct applications as we only need to figure out how they have conceptualized the notion of derivative and we need to focus on the functional thinking of students about it. In the first question, we tried to put the student in the general frame with a theoretical question as we asked for the formal definition of the derivative at a point 'a'. The result suggests that the formal definition of this concept is known and the reliance on graphical representation as a definition of the concept. Then, we asked them about what comes to their mind when they hear the word derivative and about whether they have something in mind that links the concept of the derivative to any object in real life. The results show that the graphical representation, the formal definition, the derivative of particular function, the monotonicity and the extremum of function are the main representations in regards to the notion of the derivative. Furthermore, it shows that the graphical representation represents their most main representation of this concept. While the instantaneous speed and the acceleration account for only a very small minority of the answers. As for the link between the concept of the derivative to any object in real life the results suggest that a small minority of participants identify the instantaneous speed and average speed along with identifying the courses of mechanics and chemistry and other courses as areas in which they applied this concept. As for sixteen percent of participant stated that they have no idea and others stated that there is no link between this concept and real life and this result reflects the misunderstanding of students about this concept and their uses of it are limited to mere direct applications. Following that, we asked students what is the rate of change of a function defined on an interval I, and the results suggest that the majority of students do not know the definition of the rate of change of a function over an interval although they know the definition of the derivative at a point. We discovered that 9% of them believed that the rate of change of a function 'f' between two input values is the difference between two function's output values, so they confused the rate of change of a function 'f' with the amount of change of the function values (the change in the output values).

We followed this question by an exercise containing two interlinked questions on Hooke's Law. This situation is well known by the students, they have already studied it in mechanics courses, and they used it before in mathematics courses. We gave them the force-deformation curve which is a straight line passing through the origin in order to solve the questions and we asked them in the first question to determine the rate of change from the graph of the applied force F as a function of displacement x. Just 9 students recognized that the rate of change had to be interpreted as the slope, using the short specific formula for computing the slope of a proportional function, and they were among those who already knew what rate of change definition. Then we ask a subordinate question about the spring constant k. Only five percent of the participants linked this question with the first question. Eighty-three percent of students responded to this question but they did not connect the two questions and all of them used the particular short formula of computing the slope of proportional function. These results suggest that the majority of students (ninety-five percent) fail in making a correspondence between the rate of change and the slope. The results insure that the students know that the constant 'k' is the slope of the linear graph and this means that in terms of the law of physics and direct application of slope of proportional function they have no problems but the problem lies in

making the correspondence between the rate of change and the slope. This means that they are already familiar with the concept of slope but it is not the case with the concept of rate of change. This result assures that the notion of rate of change is not well-assimilated and the students cannot interpret the rate of change graphically.

By looking at a car's speedometer at any instant, one can know the instantaneous speed of a car, and this idea should be adopted by all the students but the survey found that the majority of students answered by the average speed. The result suggests that the students confuse the instantaneous speed with the notion of the speed and not all students have access to the fact that the speedometer is an instrument that measures and displays the instantaneous speed of a car. The results of the question, which is about the connection between the rate of change and the speed, indicated that only one-third of students understand that the speed is a special case of the rate of change interpretation. This misunderstanding is due by and large to the lack of familiarity with the notion of the rate of change. As well as, they get used to define speed as a distance divided by time and they do not get used to define it as a rate of change. Thus, this result also assures that the notion of the rate of change is not well-understood.

The interview also allows us to conclude that students do not have a strong concept image of the concept of the derivative. It shows the fragmented image they have about it. They only can relate it to direct applications on physics or mechanics. This accounts for the fact that the student regards the derivative as a tool they can work within the other discipline. Even when the students were asked what does the speedometer in a car measure, they were reluctant and hesitant between whether the measure was instantaneous velocity or average velocity and they were unable to justify their answers in both cases. In this case, we intervened with an insight about the derivative and the rate of change and asked about what connection they have between each other and how we would use them in relation to velocity. But even with this insight, they remained clueless as, from the beginning, they cannot think of these terms as puzzles of a greater image but think of them as independent terms with no connection between each other; which again accounts for the distorted image they have in their minds about the derivative concept and the terms that relate to it. Thus, the results assure that the notion of the rate of change, which is closely related to the notion of the derivative is not well-assimilated and well-understood. Not only that, due to this misunderstanding, we can conclude that the notion of the derivative at a point is not well understood either and the students have not a strong concept image about the physical notions which are closely related to the concept of the derivative.

REFERENCES

- Chevallard, Y. (1980). The didactics of mathematics: its problematic and related research. *Proceedings of the fourth International Congress on Mathematical Education*. 2 (1), p. 146-158. Berkeley.
- Tall, D., & Vinner, S. (1981). Concept image and concept definition in mathematics, with special reference to limits and continuity. *Educational Studies in Mathematics*, 12(2), 151-169.

Characterizing Calculus-based physical explanations in terms of rationality: the case of motion in resources for high school teachers

Laura Branchetti¹

¹Department of Mathematics “F. Enriques”, University of Milan (Statale);

laura.branchetti@unimi.it

Abstract

In this paper, we carry out a comparison between physical explanations presented in different disciplinary-based resources that can be consulted by high school physics and mathematics teachers to design their lessons. The goal of the analysis is to figure out some specificities of explanations exploiting concepts and methods of Calculus compared to other choices for mathematization in physical modelling. We focus on the case of motion, that is a relevant context for Calculus, also from a historical point of view. The core methodology of the study is a qualitative analysis of excerpts of texts, with the lens of Habermas’ rational behavior developed as an analytical tool for mathematics education, exploiting the distinction between different mathematical rationalities related to different mathematical domains, extended to the case of physics. The integrated analysis aims to connect the mathematical domains involved in the mathematization and the kind of scientific explanation presented in different resources. As we will show, the analyses showed differences between the rationality of different explanations in different kinds of resources in excerpts concerning the same topic and showed epistemic, teleological and communicative differences between scientific explanations involving different mathematical domains.

Goal and background of the study

In this paper, we carry out a comparison between different disciplinary-based resources that can be consulted by high school physics and mathematics teachers to design their lessons in order to figure out some specificities of explanations exploiting concepts and methods of Calculus compared to other choices for mathematization that can be made in physical modelling. In this work we focus on the case of motion, that is a relevant context for Calculus, also from a historical point of view.

The main ideas of this work arose from results of a previous study (Branchetti, Cattabriga, Satanassi & Levrini, in press) about a comparison between proofs of the fact that the trajectory of motion of a projectile is parabolic in an historical text by Galilei (1638, reference can be found in *ibid.*, in press) and a physics textbook for high school. The authors analysed the excerpts using the lens of cognitive unity and compared them in terms of continuity and rupture between argumentations and proofs in the two texts. From the analysis it emerged that the textbook had much more elements of rupture and that, as long as algebraic rationality appeared in the text - generalization, use of symbolic expressions of laws, search for a solution of a system - the structure of the explanation changed in a significant way. Moreover in the text different mathematical domains coexisted, but rarely efforts were made to pursue cognitive unity when mathematics appeared in the explanations and to intertwine both mathematical rationalities and mathematical and physical explanations (Boero, Morselli & Guala, 2013).

The sudden change of rationality of the product during the explanation can interrupt the reasoning and result in strong difficulties to follow the argument, in particular in students not used to articulating different rationalities at the same time. In the case of the historical textbook we observed a much more careful choice in terms of mathematization and more unity between mathematical proof and scientific argumentation, thanks to the use of Euclidean geometry to

mathematize the problem and the consistent rationality used to carry out the proof (Branchetti et al., in press). However, Galileo's proof has been discussed a lot both from a mathematical and physical point of view, e.g. because of its generalization strategy from horizontal velocity of the motion of the projectile before combining it with an accelerated vertical motion to all the possible cases (not stating the law of inertia in a general form) or the controversy about the paternity of the proof with Cavalieri (Drake & MacLachlan, 1975).

Leaving aside the debate itself, it is very interesting to compare different proofs and explanations, reflecting also on the choices made (and possible at that time!) in terms of use of mathematical rationality in physical explanations. Indeed, a crucial difficulty shown by research in physics education, that is often simplified as the difficulty in the *use* of mathematics in physics, does not really mirror the complexity where students can feel trapped and lost, that often have a lot to do with structural rather than instrumental role of mathematics in physical modelling (Udhen, Karam, Pietrocola & Pospiech, 2012). Moreover, the analysis of textbooks shows that a lack of awareness about the intertwining between rationalities can result in presentations of physical explanations where mathematics interrupt the flow of reasoning rather than strengthening, generalizing, formalizing it, as it is reasonably expectable.

We considered it particularly interesting to investigate such an issue in particular analysing historical or contemporary resources where Calculus is gradually introduced, not only as a tool but as a mathematical new theory with its own specific, even evolving, epistemology and rationality. By comparing similar and different explanations, extending the analysis also to other key cases of motions, it is possible to search for specificities of Calculus-based explanations in physics.

The main research questions we address in this paper are:

RQ1: Are there patterns in terms of rationality in Calculus-based explanations related to motion in different resources for mathematics and physics teachers (mathematical or physical historical texts, essays, manuals, textbooks) that allow us to characterize the main features of such explanations in the case of the physical study of motion from a cinematic and dynamics point of view?

RQ2: Are there significant differences between different resources for teachers? If so, are they depending on the discipline (mathematics or physics), on the target (scientific community, university, high school teachers, students, ...) or on other variables related to the intertwining between mathematical and physical rationalities of the choices made for the particular explanation?

Theoretical framework

The theoretical construct of rational behavior was adapted to mathematics education in Morselli and Boero (2009) for the analysis of students' discursive practices, especially in the conjecturing and proving process. According to the authors, the rational behavior consists of three deeply interrelated dimensions: we talk about *epistemic* rationality when actions acted by an agent are consciously validated and shaped according to a theoretical framework and to reasoning rules shared by the community; we talk about *teleological* rationality when actions acted by the agent are consciously chosen aiming at reaching goals of the activity; we talk about *communicative* rationality when communicative means used by the agent to share results are adequate to that of community. In the disciplinary transposition that is generally carried out in schools, in mathematics an artificial internal division emerges that separates it into the domains algebra, geometry, analysis, statistics and so on (Boero et al., 2013). The artificial introduction of algebra as a separate field from geometry and other areas of mathematical knowledge implies that students have difficulty using algebraic language in proofs, thought mainly in secondary school as a domain of synthetic geometry, leading to a radical change in the forms of rationality moving from geometry to algebra.

For what concerns scientific explanations we will refer to Braaten & Windschitl (2011), who stressed that “from a philosophical perspective, there are many ways of conceptualizing scientific explanations, all of which can be relevant for research and practice in science education.” (ibid., 2011; p. 3) and analysed in depth five models of scientific explanation from the point of view of their epistemic relevance and their role in science education:

- *Covering Law* (deductive arguments explaining events as natural, logical results of regularities expressed by laws; merits depend on logical coherence of the argument showing an event to be the expected result of a natural law)
- *Statistical-Probabilistic* (Induction from a trend or pattern in data may or may not seek underlying causes for events; merits of explanation depend on degree of coherence between explanation and data)
- *Causal* (Induction from patterns in data, but explicitly seek underlying causes for events; merits depend on coherence with data and on degree of confidence in establishing causation)
- *Pragmatic* (Relies on shared agreement about the “contrast class” inherent in the why-question: Why is this (and not that) the case? Attributes negotiated and deemed acceptable by participants in conversation; varied assumptions about contrast class may cause disagreement about what makes a satisfactory explanation)
- *Unification* (Explanations for singular events are unified into generalizations through use of major theories in science; merits depend on degree to which an idea connects otherwise disconnected phenomena and coheres with other accepted explanations in the ‘explanatory store’).

Methodology

The core of the study is the analysis of excerpts of texts, that are chapters of different resources for teachers, with the lens of Habermas’ rational behavior developed as analytical tool for mathematics education (Morselli and Boero, 2009), adapted to the case of interdisciplinary analysis of physical resources by Pollani, Branchetti & Morselli (2022). We rely on the distinction between different mathematical rationalities related to different mathematical domains (Boero et al., 2013), but we extend the notion of rational behavior to the case of physical rationalities related to explanations and analyse the intertwining between mathematical and physical rationalities searching for specificities in the case of Calculus-based rationality in physical explanation related to motion.

The resources have been analysed as examples of prototypical presentation of physical explanations where mathematics plays a role and are meant as cultural or institutional crystallized products that can be consulted by high school teachers to prepare a lesson. With this respect they are considered resources relevant to teaching, and not teaching resources. The process of designing and implementing a lesson plan is of course much more complex and depends on several variables (the teacher *in primis*) that are not considered in this paper, so we are not drawing conclusions about the way teachers effectively use such resources in their classrooms. The analysis is mainly epistemological and concerns the choices made by the authors of such resources considered as rational agents within a precise context - a scientist referring to a scientific community in the case of historical sources, the textbooks’ authors addressing a text to high school teachers and students as targets of their communication.

Consistently with the framework, we characterize the different explanations in terms of mathematical and physical epistemic, teleological and communicative rationality (Boero and Morselli, 2009). The integrated analysis aims to connect the mathematical domains involved in the mathematization and the kind of scientific explanation presented in different resources.

Data analysis and discussion

A corpus of resources has been analysed ranging from Newton's main historical sources, to books addressed to teachers about the history of infinitesimal - in particular differential - Calculus and history of physics to manuals and textbooks. During the conference we will show some examples of analyses and compare them in order to provide our first answers to the research questions. As we will show, the analyses showed differences between the rationality of different explanations in different kinds of resources, even in excerpts concerning the same topic, and showed epistemic, teleological and communicative differences between scientific explanations involving different mathematical domains.

We present here just two interesting aspects that emerged. At the epistemic and communicative level there are differences in the formulation of the axioms, in the role of the examples and in the structure itself of the explanation and of the mathematical aspects of the physical proof depending on the mathematical rationality adopted. The use of graphical representations, for instance, is slightly different in Galileo's and Newton's approach, and in textbooks: some adopt a synthetic point of view, others a Cartesian, others an analytic point of view; in the textbooks we can find a mix of different uses of graphs where the use of such tools in the reasoning is often not explicitly declared and clarified. From the point of view of the teleological dimension of rationality, it is interesting to observe the Calculus-based explanation that describe and analyse phenomena relying mainly on functions are more likely to encourage, or even implicitly assume, a covering-law teleological attitude towards explanation (e.g. the goal pursued is to find the law that phenomena is expected to obey to). Such results, even preliminary, allowed us to characterize such explanations in the case of motion, but we aim at extending the investigation to other physical topics, reflecting also on the dependence on the physical theories within which the explanation is developed.

References

- Boero, P., Guala, E., & Morselli, F. (2013). Crossing the borders between mathematical domains: A contribution to frame the choice of suitable tasks in teacher education. *Proceedings of the 37th Conference of the IGPME* (Vol. 2, pp. 97–104).
- Braaten, M., & Windschitl, M. (2011) Working toward a Stronger Conceptualization of Scientific Explanation for Science Education. *Science Education*, 95, 639-669.
- Branchetti, L., Cattabriga, A., Satanassi, S., Levrini, O. (accepted). Continuity and rupture between argumentation and proof in historical texts and physics textbooks on parabolic motion. *Proceedings of CERME12*.
- Drake, S., & MacLachlan, J. (1975). Galileo's Discovery of the Parabolic Trajectory. *Scientific American*, 232, 102–110.
- Morselli, F., & Boero, P. (2009). Habermas' construct of rational behavior as a comprehensive frame for research on the teaching and learning of proof. In M. De Villiers, G. Hanna, F. L. Lin, & F. J. Hsieh (Eds.), *Proceedings of the International Commission on Mathematical Instruction Study 19 Conference: Proof and Proving in Mathematics Education* (Vol. 2, pp. 100–105). Taipei: Normal University.
- Pollani, L., Branchetti, L., & Morselli, F. (2022). Habermas' construct of rationality to bring out mathematics and physics disciplinary identities. *Proceedings of the 45th Conference of the IGPME* (Vol. 4, p. 276).
- Udhen, O., Karam, R., Pietrocola, M., & Pospiech, G. (2012). Modelling Mathematical Reasoning in Physics Education. *Science & Education*, 21, 485–506.

What knowledge related to the derivative is commonly used in basic economics textbooks? – Selected results from a praxeological analysis

Frank Feudel

Humboldt-Universität zu Berlin, Germany; feudel@math.hu-berlin.de

Introduction

Concepts of calculus play an important role in many study programs, for instance, STEM-programs, but also economics. However, the way these concepts are used in the corresponding disciplines sometimes differs from how they are treated in calculus courses for students of these disciplines (González-Martin, 2021; Hitier & González-Martin, 2022). Sometimes, there are even discrepancies between the way mathematical concepts are understood and taught in mathematics and the way they are used in other disciplines, which can make it hard for students to make a connection between these two issues (Feudel & Biehler, 2022). Therefore, it is important to investigate how mathematical concepts are used in other disciplines, and which knowledge related to these concepts can help students understand this usage.

I explored this issue in my PhD-project for the derivative and its usage in economics, and found that – from a cognitive perspective – economics students need a broad knowledge of the concept for being able to make sense of the material in basic economics textbooks (Feudel, 2019). This led to the question of whether one can systematize this knowledge into “blocks” that are used commonly. I therefore analyzed the textbooks once again – now from a perspective that compartmentalizes knowledge into units and which highlights that knowledge is institutionally situated – to find an answer to the question: *What pieces of knowledge related to the derivative are commonly used in basic economics subjects?*

Theoretical framework

I used the Anthropological theory of the didactic (ATD) by Chevallard (2019) for this analysis. According to the ATD, knowledge is considered as a relation between people and certain objects. This relation evolves through activities with these objects within certain institutions. For analyzing such activities, the ATD introduces the notion of praxeology, which is the basic unit of such activities. A praxeology consists of four parts: 1) a type of task that needs be handled, 2) a technique for handling the task, 3) a technology that explains and justifies the technique, and 4) a theory that justifies the technology. The emphasis in this paper lies on the technologies used in basic economics subjects, as these are essential for gaining an understanding of the used techniques.

Methodology

I analyzed two basic economics textbooks that are widespread in Germany: the book “Introduction to general business administration” by Wöhe and Döring (2013) – a standard reference for business administration courses, and the book “Basics of microeconomics” by Varian – a standard reference for basic microeconomics courses. Of the latter, there also exists an international version in English (Varian, 2014), which I used for the analysis presented here, so that no extra translation is needed.

I analyzed all the book chapters containing the derivative with a two-step method used by Vom Hofe (1998) in a study on students' conceptions of limit. This method discriminates consequently between description and interpretation, so that the genesis of the results can be clearly reconstructed by others. In a first step, *the description level*, I described the content of each paragraph involving the derivative precisely. In the second step, *the reflection level*, I tried to identify the praxeologies or parts of such that can be found in the paragraph. I will also present the results this way here.

Some results of the textbook analysis

In this paper, I want to present *two examples* illustrating that the textbooks analyzed basically rely on three different technologies when explaining techniques used. **The first example** is from Varian (2014) from the chapter “profit maximization”, and is generic for other optimization tasks as well.

Description level: Varian illustrates how maximal profit can be determined by looking at a firm using two inputs x_1 and x_2 to produce an output y via a production function $y = f(x_1, x_2)$ (p. 371). He first looks at the case that x_2 is fixed at a level $\overline{x_2}$ (the case that x_2 varies is discussed later). If w_i denote the prices for the inputs and p the price for the output, the following expression needs to be maximized with respect to x_1 : $p \cdot f(x_1, \overline{x_2}) - w_1 x_1 - w_2 \overline{x_2}$. Varian then states that the profit maximizing input x_1^* fulfills the equation $p \cdot MP_1(x_1^*, \overline{x_2}) = w_1$ in which MP_1 denotes the marginal product of good 1 that he had defined as the derivative of the production function with respect to x_1 earlier. He derives the equation $p \cdot MP_1(x_1^*, \overline{x_2}) = w_1$ via the first order condition $p \cdot \frac{\partial f(x_1^*, \overline{x_2})}{\partial x_1} - w_1 = 0$.

Reflection level: Varian proposed using the equation $p \cdot MP_1(x_1^*, \overline{x_2}) = w_1$ as a technique to find the profit maximizing input x_1^* , and used symbolic techniques involving the derivative (differentiation rules and first order condition) as technology for justifying this equation.

Description level: He then explains in a second way why this equation must be valid at the optimal input x_1^* . If you add a little more of factor 1 (δx_1), you produce $\delta y = MP_1 \cdot \delta x_1$ more output that is worth $p \cdot MP_1 \cdot \delta x_1$. But this output costs $w_1 \cdot \delta x_1$ more to produce. If the value of $p \cdot MP_1 \cdot \delta x_1$ does not equal the costs $w_1 \cdot \delta x_1$, the profit can be raised by increasing or decreasing input 1, and then x_1^* was not the optimal input. Hence, $p \cdot MP_1$ needs to be equal to the price w_1 at the optimal input.

Reflection level: Here, Varian used a second technology to explain the equation $p \cdot MP_1(x_1^*, \overline{x_2}) = w_1$ at the profit maximizing input. It utilized the context and relied on an economic interpretation of the derivative $MP_1 = \frac{\partial f}{\partial x_1}$ as a rate of change – used to examine the effect of small changes in the input.

Description level: Finally, Varian derives the equation $p \cdot MP_1(x_1^*, \overline{x_2}) = w_1$ also with a graphical method. For this, he expresses the output y that yields the profit π as a function of the input x_1 via $y = \frac{\pi}{p} + \frac{w_2}{p} x_2 + \frac{w_1}{p} x_1$. For each profit π , this expression describes a line, and as π varies, one gets a family of parallel lines, so-called *isoprofit lines* (see Figure 1). Since only outputs given by the production function $y = f(x_1, \overline{x_2})$ can be practically realized, the maximal profit is given by the line that just “touches” f as a tangent. Hence, at the optimal input, the slope of the corresponding isoprofit line ($\frac{w_1}{p}$) must be equal to the slope of the production function, which yields $MP_1 = \frac{w_1}{p}$.

Reflection level: Varian finally presented a third technology for deriving the equation $p \cdot MP_1(x_1^*, \overline{x_2}) = w_1$ for the profit maximizer. It is based on graphical methods, and relies on the geometric interpretation of the derivative MP_1 as slope of the production function.

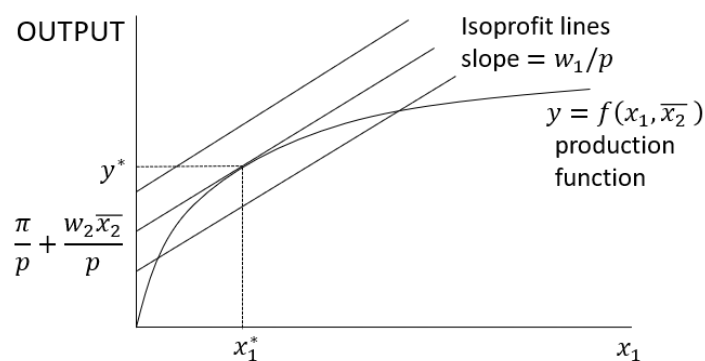

Figure 1: Graphical method to derive the condition $p \cdot MP_1(x_1^*, \bar{x}_2) = w_1$ for maximal profit (p. 373)

The second example I want to present here, which is also from Varian (2014), shows that the three technologies just illustrated may also be intervened. This example is about marginal cost, and illustrates how relationships between different quantities are explored and derived in economics.

Description level: Varian defines marginal cost as a rate of change (p. 402): $MC(y) = \frac{dc}{dy}$, whereby $c(y)$ is the cost in dependence of the output produced. He then argues that when interpreting $MC(y)$, dy is often considered as one, so that the marginal cost is interpreted as the cost of the next unit. If the good does not need to be discrete, he wants to think of marginal cost as a derivative, and always uses the derivative to determine marginal costs or to illustrate $MC(y)$ as a curve.

He then derives how the marginal cost curve is related to other cost curves, in particular the average variable costs $AVC(y) = (c_v(y) / y)$, $c_v(y) = c(y) - F$ if F are the fixed costs. He first mentions that both curves approach each other for $y \rightarrow 0$ because $\lim_{y \rightarrow 0} MC(y) = \lim_{y \rightarrow 0} \frac{c_v(y) + F - c_v(0) - F}{y} = \lim_{y \rightarrow 0} \frac{c_v(y)}{y}$.

Reflection level: He used limits and a symbolic representation of $MC(y)$ as the rate of change of the costs $c(y)$ as technology to justify the relationship between $MC(y)$ and $AVC(y)$ for $y \rightarrow 0$.

Description level: He then considers ranges of the output in which the average variable costs AVC are decreasing, and argues that the marginal cost curve must lie below the AVC -curve in these ranges. He justifies this relationship using an economic context first. As long as the AVC are decreasing, the cost of each additional unit must be less than the average, because “to make the average go down, you have to be adding additional units that are less than the average” (p. 403).

Reflection level: Varian used the common economic interpretation of the derivative $MC(y)$ as cost of the next unit to explain the relationship between $MC(y)$ and $AVC(y)$ if the AVC are decreasing.

Description level: Varian then derives the relationship also symbolically. He argues that, since the AVC -curve is decreasing, the derivative of $AVC(y) = c_v(y) / y$ needs to be < 0 . He then derives with the quotient rule the relationship $c_v'(y) < (c_v(y) / y)$, which implies that $MC(y) < AVC(y)$.

Reflection level: Varian explained the relationship between $MC(y)$ and $AVC(y)$ if the AVC are decreasing in a second way by using symbolic techniques and the connection between the sign of the derivative and monotonicity that relies on the geometric interpretation of the derivative as slope.

Description level: Varian then justifies economically again, why the marginal costs need to be above the average variable costs (AVC) if the latter are increasing, and that both costs are equal at the minimum of the AVC . Finally, he presents a diagram with both cost curves and the average cost.

Conclusion and discussion

In the books analyzed, basically three aspects of the derivative appear commonly – especially in the technologies explaining the techniques used. These are: 1) a geometric interpretation of the derivative as slope that often occurs in graphical approaches used to illustrate relationships between economic quantities or to determine optima, 2) an economic interpretation of the derivative that is commonly used to derive relationships between economic quantities with contextual arguments, and 3) techniques for working with the derivative on the symbolic level, e.g., differentiation rules or the first order condition that are often used to solve optimization problems analytically.

This shows that – differently from what González-Martín (2021) found for engineering – symbolic techniques taught in calculus courses for economics students also often appear in basic economics textbooks. But two further aspects of the derivative also occur frequently: a geometric interpretation as slope and an economic interpretation. These are not only used for illustration or for interpreting results in the context, but also for explaining and deriving relationships between different economic quantities. Hence, it is important to emphasize these two aspects of the derivative more in calculus courses for economics students – also within reasoning – for providing the students with knowledge of the derivative that really helps them to make sense of the content of their major subjects.

References

- Chevallard, Y. (2019). Introducing the anthropological theory of the didactic: An attempt at a principled approach. *Hiroshima journal of mathematics education*, 12, 71–114.
- Feudel, F. (2019). *Die Ableitung in der Mathematik für Wirtschaftswissenschaftler* [The derivative in mathematics for economics students]. Springer.
- Feudel, F., & Biehler, R. (2022). Students' Understanding of the Economic Interpretation of the Derivative in the Context of Marginal Cost. *International Journal of Research in Undergraduate Mathematics Education*, 8(3), 437–468.
- González-Martín, A. S. (2021). $\int_A^B f(x) dx$. The Use of Integrals in Engineering Programmes: a Praxeological Analysis of Textbooks and Teaching Practices in Strength of Materials and Electricity and Magnetism Courses. *International Journal of Research in Undergraduate Mathematics Education*, 7(2), 211–234.
- Hitier, M., & González-Martín, A. S. (2022). Derivatives and the Study of Motion at the Intersection of Calculus and Mechanics: a Praxeological Analysis of Practices at the College Level. *International Journal of Research in Undergraduate Mathematics Education*, 8(2), 293–317.
- Varian, H. R. (2014). *Intermediate microeconomics with calculus*. W.W. Norton & Co.
- Vom Hofe, R. (1998). Probleme mit dem Grenzwert – Genetische Begriffsbildung und geistige Hindernisse. *Journal für Mathematik-Didaktik*, 19(4), 257–291.
- Wöhe, G., & Döring, U. (2013). *Einführung in die allgemeine Betriebswirtschaftslehre* [Introduction to general business administration]. Vahlen.

On motivation and narrative in discipline-specific calculus texts

Haile Gilroy¹ and Melinda Lanius²

¹Auburn University, United States; hmg0038@auburn.edu

²Auburn University, United States; melinda.lanius@auburn.edu

Because life science students are historically outperformed by their peers in calculus (Eaton & Highlander, 2017), many colleges and universities now offer a discipline-specific calculus course, with core calculus concepts motivated by and contextualized within life sciences (e.g. see Luque et al., 2022). Because motivation can improve student engagement (Akbuga & Havan, 2022), a ‘biocalculus’ theoretically should improve performance outcomes for biology majors. However, preliminary evidence indicates this curriculum is not effective at improving life science students’ academic performance (Eaton & Highlander, 2017; Luque et al, 2022). To investigate, we will compare a biocalculus to a business and standard curriculum. Because textbooks are a near universal course component that mediates teaching (Mesa & Griffiths, 2011), we will use textbook analysis to explore structural differences in presenting a core concept of calculus: the derivative. Our research question is: *How do discipline-specific calculus textbooks develop the definition of the derivative compared to a general calculus text?* Our corpus is *Calculus: Early Transcendentals*, eighth ed. by Stewart (2016), which is typically presented to math, engineering, physics, and chemistry majors; *Calculus for Business, Economics, and the Social and Life Sciences*, brief tenth ed. by Hoffmann & Bradley (2010); and *Calculus for Biology and Medicine*, fourth ed. by Neuhauser & Roper (2018). We refer to these texts as CALC, BUSCALC, and BIOCALC, respectively.

Narrative Analysis

To compare how the three texts present the definition of the derivative, we conducted a narrative analysis using the graph framework developed by Weinberg, Wiesner, and Fukawa-Connelly (2016). In brief, narrative analysis is a technique borrowed from literature studies that considers the sequence of ideas and how earlier items influence and shape the presentation of later concepts. We coded the following key ideas in the presentation of the definition of the derivative: **A.** secant lines limiting to a tangent line, **B.** formula for the slope of a tangent line, **C.** instantaneous velocity at a point, **D.** derivative at a point, **E.** instantaneous rate of change at a point, and **F.** the derivative function. In Figure 1, a solid arrow indicates that the tail idea was utilized in presenting the idea at the head of the arrow. A dashed arrow represents an imprecise motivation rather than an explicit linking of ideas.

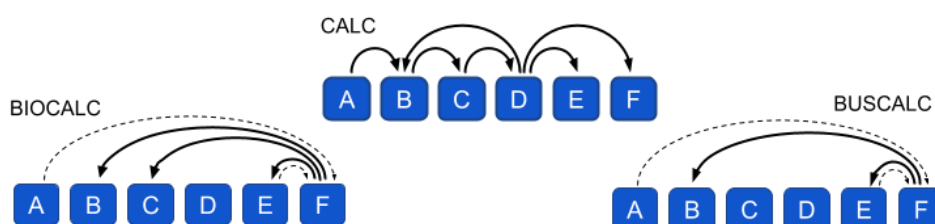

Figure 1: Narrative graphs for the definition of the derivative in each text

The graphs reveal that narratively, BIOCALC and BUSCALC were quite similar, painting a motivating picture before beginning their rigorous discussion with the definition of the derivative function. From this function starting point, the reader is then shown numerous “applications” of the derivative. On the other hand, the CALC text assembles the derivative function by piecing together the point-wise derivative and directly links the concept of slope of a tangent line, instantaneous velocity, and the derivative at a point.

Network Analysis

To analyze the development of the definition of the derivative in each textbook, we constructed a directed graph, or digraph, in yEd (Version 3.22, yWorks GmbH) as follows: the vertices of the digraph are mathematical objects (concepts, definitions, theorems, examples, and exercise types) organized into four groups ordered from left to right: Prior Knowledge (not in the text), Prerequisites (in the text), Section (introducing the limit definition of the derivative), and Exercises (for the section). Draw an arrow from one vertex, x , to another vertex, y , if x is required to learn y .

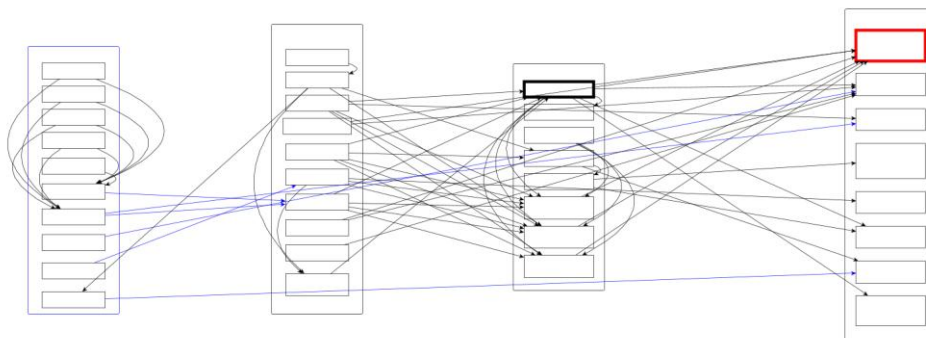

Figure 2: Development of the definition of derivative in BIOCALC

Figure 2 shows the digraph for BIOCALC’s development of the definition of derivative. For clarity, the vertex corresponding to the definition of the derivative is bolded in black and all arrows from a prior knowledge vertex to an in-text vertex are colored blue. Digraphs were also created for the other two textbooks, but we omit them here due to space restrictions. These will be included in future work, which will also include a larger corpus and more rigorous analyses.

Visual Inspection

Initial visual inspection of the digraphs revealed that CALC required the most prior knowledge not in the text (see Table 1). However, BUSCALC required the most prerequisite knowledge in the text. This is because many of the concepts included in BUSCALC were assumed to be prior knowledge in both CALC and BIOCALC. BIOCALC had the least number of concepts presented in the section covering the definition of the derivative as well as the least variety in types of exercises.

Since a goal of discipline-specific calculus is to apply calculus concepts to other disciplines, we analyzed each textbook’s attention to application problems by computing the proportions of example problems and exercises pertaining to applications (App.) in each textbook’s section on the definition of the derivative (see Table 2).

Textbook	No. of Prior Knowledge Vertices	No. of Prerequisite Vertices	No. of Section Vertices	No. of Exercise Vertices
CALC	13	16	16	17
BUSCALC	8	20	15	12
BIOCALC	10	10	8	8

Table 1: Prior knowledge, in-text prerequisites, section concepts presented, and exercises pertaining to the definition of derivative

Textbook	No. of App. Examples	No. of Examples	App. Examples Prop.	No. of App. Exercises	No. of Exercises	App. Exercise Prop.
CALC	3	7	43%	20	61	33%
BUSCALC	3	7	43%	15	65	23%
BIOCALC	0	3	0%	0	38	0%

Table 2: Proportions of application examples and exercises in section on definition of the derivative

Each black arrow between categories in the digraph indicates in-text preparation for successive concepts. Thus, a quick measure of how well the text prepares the reader for exercises relating to the definition of the derivative may be gleaned by counting the number of black arrows pointing to each exercise vertex (the *indegree* of a vertex). In CALC, the exercise vertex with maximum indegree was “Find the equation of the tangent line to the curve at the given point” with 4 arrows. In BUSCALC, there was a three-way tie between “Find the rate of change at the given point”, “Application word problems”, and “Proofs involving differentiation” each with 3 arrows. In BIOCALC, “Find the derivative of a function at the given point” had maximum indegree with 6 arrows (indicated in Figure 2 by the red bolded vertex). Furthermore, in BIOCALC, the majority of black arrows clustered at just two exercise vertices, indicating more variation in preparedness for certain exercise types than both CALC and BUSCALC.

Centrality Analysis

Following the initial visual inspection, we used two measures of centrality to analyze the digraphs: degree and node betweenness. For both measures, a value of 1 indicates the topic(s) most emphasized in the presentation of the definition of the derivative. Degree centrality measures the number of arrows connected to a vertex (*degree* of a vertex) relative to the maximum degree in the digraph. In CALC, two topics had degree centrality 1 (“Geometric interpretation of secant & tangent lines” and “Definition of derivative”), whereas in BUSCALC and BIOCALC, “Definition of derivative” was the lone topic with degree centrality 1. To explain node betweenness centrality, imagine that a vertex is a train station. A train station is “between” a pair of cities if we must stop there to travel between the two cities. The number of pairs of cities that a given train station is between is the train station’s “betweenness”. Taking this measure relative to the maximum

betweenness among all train stations is node betweenness centrality. All three texts had exactly one topic with node betweenness centrality 1. In CALC, it was “Geometric interpretation of secant & tangent lines”, while in both BUSCALC and BIOCALC, it was “Definition of derivative”. The centrality analysis results suggest that CALC contains two concepts that compete for importance in the development of the definition of derivative, while BUSCALC and BIOCALC focus most on the definition of the derivative itself.

Discussion

Through our narrative and network analysis of general calculus, business calculus, and biocalculus textbooks, we found significant structural differences between the general text and the two discipline-specific texts. The discipline-specific texts emphasized the definition of the derivative most, while the general text emphasized the definition’s geometric roots so much that this competed for importance with the definition itself. More analysis needs to be done to determine whether these competing topics benefit or hinder learning. Furthermore, between the two discipline-specific texts, there were differences in presenting the definition of the derivative, namely in emphasis on application problems and exercise preparedness. The business calculus text both emphasized applications more and better prepared the reader for its exercises concerning the definition of the derivative than its biocalculus counterpart. These structural differences in the texts may explain the lack of improvement in performance outcomes for life science students. Curriculum designers should note when selecting textbooks: the stated aim of a biocalculus course, with core calculus concepts remaining but with life science context, was not supported by the BIOCALC text. Further, our analysis suggests education researchers should be careful to decouple motivation from narrative structure differences when comparing student performance outcomes between calculus and discipline-specific calculus courses.

References

- Akbuga, E., & Havan, S. (2021). Motivation to study calculus: measuring student performance expectation, utility value and interest. *International Journal of Mathematical Education in Science and Technology*, 1-18.
- Eaton, C. D., & Highlander, H. C. (2017). The case for biocalculus: Design, retention, and student performance. *CBE—Life Sciences Education*, 16(2), ar25.
- Luque, A., Mullinix, J., Anderson, M., Williams, K. S., & Bowers, J. (2022). Aligning Calculus with Life Sciences Disciplines: The Argument for Integrating Statistical Reasoning. *PRIMUS*, 32(2), 199-217.
- Mesa, V., & Griffiths, B. (2012). Textbook mediation of teaching: An example from tertiary mathematics instructors. *Educational Studies in Mathematics*, 79(1), 85-107.
- Weinberg, A., Wiesner, E., & Fukawa-Connelly, T. (2016). Mathematics lectures as narratives: Insights from network graph methodology. *Educational Studies in Mathematics*, 91(2), 203-226.

Meeting the biocalculus challenges: a reflection on didactic transposition processes in a cross-disciplinary context

Thomas Hausberger¹ and Bernard Godelle²

¹University of Montpellier, France; thomas.hausberger@umontpellier.fr

²University of Montpellier, France; bernard.godelle@umontpellier.fr

Introduction

Two special issues have recently appeared in *Primus* on the theme of “Mathematics and the Life Sciences” (Robeva et al., 2022). Despite various institutional injunctions since the early 2000s in the USA, the desired reform of a greater integration of mathematics and biology in the undergraduate curricula seems slow to materialize. In this context, the special issue presents approaches undertaken by different academic communities to meet the challenges of biocalculus.

Understanding how the contents of university mathematics education (UME) came to be what they currently are, as well as how they evolve (or are submitted to inertia) under various sorts of institutional conditions and constraints is an endeavor undertaken by the Anthropological Theory of the Didactic (ATD; Chevallard & Bosch, 2020) under the name *didactic transposition* (Bosch et al., 2021). In this paper, we present a reflexive analysis of transposition processes that we participated in when the first author (a mathematician and researcher in university mathematics education) was given the responsibility of teaching and orchestrating a biocalculus course for more than 700 first-year biology students tutored by 10 mathematics instructors. The course material was developed on the basis of the official syllabus and materials provided by the second author, an evolutionary anthropologist familiar with quantitative approaches in biology. In an overall context of stability of mathematics curricula (Bosch et al., 2021), this reform of the mathematics course for biology students has been experienced as a “revolution” by mathematics teachers, a paradigm shift.

Didactic transposition processes will be modeled and discussed using ATD theoretical constructs in order to provide answers to the following research questions: What set of conditions and constraints allowed the emergence of a biocalculus course at the University of Montpellier (UM, France)? What are the characteristics of the transposition phenomena that took place, as compared to a more classical calculus course (such as the one that preceded it in Montpellier)?

Theoretical framework

In the ATD model, 3 types of institutions intervene in didactic transposition processes: the *scholarly institutions* of knowledge producers, the *school institutions* (universities), and in between the *noosphere* (curriculum designers, policymakers,...) whose agents elaborate the *knowledge to be taught* from the scholarly knowledge. This first step called *external didactic transposition* (EDT) produces the curricula and syllabi. The subsequent step towards the *actually taught knowledge* is called *internal didactic transposition* (IDT), which is achieved by the course teachers. The two processes are intertwined since a teacher can take a noospherian position (as a member of a program committee) to update the syllabus of the course he or she is responsible for.

Let us note I_{BT} and I_{MT} the disciplinary school institutions corresponding to biology and mathematics teaching, and I_B and I_M the scholarly institutions, respectively. Classical EDT

processes, e.g. calculus transposition by the mathematics noosphere, rely on series of *textualizations of knowledge* that generate a whole posterity of textbooks, rather than drawing on scholarly sources. This immediately brings out a fundamental difference with biocalculus, which has a much more recent and reduced textualization (e.g. Schreiber et al., 2014) produced by members of the scholarly interface between mathematics and biology (I_{BM} for biomathematics) or originating from the collaboration between mathematicians and biologists.

In ATD, pieces of knowledge are modeled in terms of *praxeologies* (Chevallard & Bosch, 2020). Although it remains in the hand of I_{MT} , biocalculus teaching is inevitably influenced by I_{BT} and finds its epistemological investiture in the scholarly praxeologies developed by I_{BM} . It is no coincidence that the biocalculus assessment instrument (Taylor et al., 2020) that aims to assess biocalculus comprehension in various modalities of integration of biological contexts in calculus teaching was developed by mathematics education researchers in collaboration with I_{BM} members. ATD aims at elucidating the sources of biocalculus praxeologies, in particular how standard calculus praxeologies are modified when applied to or developed within biological contexts.

External didactic transposition

Our main data to analyze the biocalculus EDT at the UM are the documents produced by the noospherian institutions. Strikingly, the process was initiated by the biology noosphere which launched a working group coordinated by a quantitative geneticist and an epidemiologist (thus I_{BM} members) with the mission to elaborate the curriculum and content of the mathematics, statistics and computer science courses of the entire biology degree in a coherent and interdisciplinary manner. The first-year first-semester mandatory biocalculus course was entitled “computational methods”, with essential content “elementary algebra and analysis”, considered as pertaining to both mathematics and informatics (due to the importance of data manipulation in biology, requiring the use of computer software) as disciplines, and entrusted to I_{MT} for its teaching. Mainly based on economic criteria, 12 h of lectures and 21 h of tutorials in groups of 40 students has been allocated.

The working group observed that biology students had a great weakness in mastering the basics of mathematics (going back to lower high school) and for some a sort of phobia of mathematics, which impacted, for example, their ability to calculate dilutions and concentrations. Moreover, the recent reform of the French upper high school was going to reinforce the heterogeneity of the students’ profiles. In other words, the biology noosphere was well aware of 2 crucial issues identified by UME research: the secondary/tertiary transition and the isolation of mathematics courses in non-mathematics majors. In such a context, minimal requirements expected from biology students to be successful in biology studies were identified (e.g. “reading an exponential or logistic curve”, “understanding of the notion of derivative”,...) and the teaching method was proposed to “start as much as possible with biological problems, then move on to formulas and calculations without demonstrations”. As a final document, a complete syllabus has been written, organized in two sectors (“elementary algebra” and “real univariate analysis”) declined under different competences (e.g. “know how to study a function”), which were associated with contents (“domain of a function, variations,...”), computational aspects (“code the Newton-Raphson algorithm to approximate a root to a given precision”) and biological applications (“optimum tolerance curves, enzymatic activity”).

This syllabus has been extensively revised by the noospherian members of I_{MT} , first the colleague in charge of the former calculus module for biology students, then the head of the program committee. The division into two sectors has been preserved (the first one renamed “basic mathematical techniques”), but the competencies have disappeared in favor of themes and topics, bringing back the classic headings (limits and continuity, intermediate value theorem, etc.). Some of the biological contextualizations have been retained, under the headings “example illustrations” which reflects well the function of the latter in the mind of the noospherian mathematicians. The coherence of a pyramidal construction of calculus concepts has determined the organization of the syllabus while the examples that go beyond the framework of a shared scientific culture have been eliminated.

Internal didactic transposition

Although the mathematical noosphere has pulled in the direction of standardizing the syllabus to I_{MT} standards to allow for teaching by its members, the challenge of authentically bringing the biological contextualizations to life to meet the new philosophy driven by the biology noosphere remains for those in charge of the IDT. The institutional issue, in the background, is the conservation of the teaching volume under the responsibility of I_{MT} . This motivated the first author (Thomas), a mathematician and didactician, to take over the teaching of biocalculus and to collaborate with the second author (Bernard), a biologist who had already taught a mathematical remediation module for first-year biology students, jointly with a physicist and a mathematician.

The documents and sources (e.g. Milo & Philipps, 2015) transmitted by Bernard to Thomas do not come from the existing biocalculus textbooks (not known to Bernard, perhaps because these TDE products are still too young to spread beyond the Anglo-Saxon culture) but from quantitative biology textbooks and Bernard’s own scholarly biomathematical practice, transposed into his biology teaching as well as into the remediation module. Thomas also looked up primary sources (e.g. Bigelow, 1921) to collect data and their representations by biologists in order to build authentic biological contextualizations bearing the rationale of calculus concepts (on this example, the scope of an exponential decay in connection with applications in predictive microbiology).

In this endeavor, informed by ATD constructs, new praxeologies specific to biomathematics have emerged. For example, model fitting praxeologies (exponential and allometric in particular), using instrumented techniques (spreadsheet and regression), occupy an important place. They require a good mastery of the properties of logarithms and the articulation between graphical and algebraic registers, in order to correctly interpret standard representations in biocalculus: on logarithmic scales, the biologist notes the measured values x where the mathematician would note the logarithm X of these values, with regular graduations. This results in the need to teach a “yoga” of x - X conversion, so that students may compute the slope properly or determine a law like Bigelow’s from the graphical representation of a fit of the data. Similarly, a proportionality relation of coefficient k between two quantities that admit a wide spectrum of variation is identified after passage in log-log coordinates by a linear regression line of slope 1 and y-intercept $\log k$. For a learner, this praxeology confuses the issue by interfering with the classical technique of drawing a regression line of slope k passing through the origin. Such examples illustrate a common phenomenon: although biomathematical praxeologies are built on classical calculus praxeologies, learned at the end of high school and completed by a more formal logos in classical calculus courses, their application in authentic biological contextualizations often requires an adaptation of

known techniques together with an additional part of the technology of the praxeology, which establishes a link with the particularities of the biological context and allows its proper application to the latter. In the eyes of the ATD, then, it is not surprising that the biocalculus assessment instrument identified log-log graphs as a source of persistent student difficulty (Taylor et al., 2020).

Conclusion and outlook

This reflective study of didactic transposition carried out at the University of Montpellier in the context of calculus for biology students, based on the theoretical constructs of ATD, underlines the essential role played by the biology noosphere, imposing the constraint of authentic biology contextualizations and the processing of data on computers (even if largely reduced to homework and its presentation in class), in the emergence of a biocalculus course that offers a better integration of calculus knowledge with biology. A favorable (even necessary) condition for the good realization of the project was the cooperation between a mathematician and a biologist whose own research is related to the field of biomathematics where the epistemological legitimacy of biocalculus lies. Without relying on the few existing Anglo-Saxon biocalculus textbooks, the interactions have converged towards classical biomathematical themes (allometry, basal metabolism, Verhulst logistic model, etc.) which are conducive to articulating mathematical work with biological stakes that meet the combined requirements of mathematics and biology teaching institutions, and which can be found in the biocalculus textbooks. This shows the existence of an attractive pole of the didactic transposition processes, which tend to converge towards a body of knowledge whose didactic efficiency is still to be shown and reinforced, due to the emergence of biomathematics specific praxeologies that need to be investigated and analyzed in relation to classical calculus praxeologies, but which bases its coherence in the scholarly practice of reference, at the interface between mathematics and biology.

References

- Bigelow, W. (1921). The Logarithmic Nature of Thermal Death Time. *The Journal of Infectious Diseases*, 29(5), 528-536.
- Bosch, M., Hausberger, T., Hochmuth, R., Kondratieva, M., & Winslow, C. (2021). External Didactic Transposition in Undergraduate Mathematics. *International Journal of Research in Undergraduate Mathematics Education*, 7(1), 140-162, [doi: 10.1007/s40753-020-00132-7](https://doi.org/10.1007/s40753-020-00132-7)
- Chevallard, Y., & Bosch, M. (2020). Anthropological Theory of the Didactic (ATD). In S. Lerman (Ed.), *Encyclopedia of Mathematics Education* (pp. 53-61). Springer.
- Milo, R., & Phillips, R. (2015). *Cell Biology by the numbers*. Garland Science.
- Robeva, R., Comar, T., & Eaton, C. (2022). Can We Bridge the Gap? Mathematics and the Life Sciences, Part 1 – Calculus-Based Modules, Programs, Curricula. *PRIMUS*, 32(2), 117-123, [doi: 10.1080/10511970.2022.2025506](https://doi.org/10.1080/10511970.2022.2025506)
- Schreiber, S., Smith, K., & Getz, W. (2014). *Calculus for the life sciences*. Wiley.
- Taylor, R., Bishop, P., Lenhart, S., Gross, L., & Sturner, K. (2020). Development of the BioCalculus Assessment (BCA). *CBE—Life Sciences Education*, 19(1), 1-12, [doi: 10.1187/cbe.18-10-0216](https://doi.org/10.1187/cbe.18-10-0216)

Investigating practices related to the derivative in kinematics contexts in calculus and mechanics courses

Mathilde Hitier¹ and Alejandro S. González-Martín²

¹Université de Montréal, Canada; mathilde.hitier@umontreal.ca

²Université de Montréal, Canada; a.gonzalez-martin@umontreal.ca

Introduction and research problem

Physics is recognized as the scientific field with the strongest ties to mathematics. In particular, the notion of derivative emerged from geometrical considerations (slope) as well as physical ones (velocity and acceleration). The derivative is one of the key notions of calculus and plays a central role in kinematics, the study of motion in mechanics. For post-secondary STEM (Science, Technology, Engineering, and Mathematics) students, it is fairly common to be enrolled in both a calculus and a mechanics course in the same year, and even the same term; students therefore encounter this notion in two different contexts. Moreover, recent research highlights the “filtering” role of calculus courses in STEM studies, which can explain the high dropout rates in STEM programs; these dropouts could also be linked to a lack of motivation in students who view calculus as being disconnected from their chosen discipline (e.g., Biza et al., 2022).

A large body of research literature in mathematics education identifies the derivative as a difficult notion for students to grasp (e.g., Thompson & Harel, 2021), and in recent years the study of *calculus for engineers and other non-mathematics professionals* has been getting more and more attention from the research community (e.g., Biza et al., 2022). Yet research in mathematics education focusing on the teaching and learning of the derivative in a physics context remains scarce (e.g., Hitt & González-Martín, 2016). Moreover, we have identified conflicting views in the literature concerning the role of physics contexts in the learning of the derivative: some researchers believe that a physics context can support learning, while others note difficulties linked to applied contexts, pointing to existing misconceptions about speed and acceleration in kinematics (Hitier & González-Martín, 2022a). We have also noticed that in these studies, “emphasis is usually placed on covariation and on the interpretation of the derivative as rate of change, and less on the physics interpretation” (p. 296).

The above considerations suggest the need for more research “investigating the relationships between calculus and these client disciplines [...], with attention to the practices of these disciplines” (Biza et al., 2022, p. 400). Therefore, our research program seeks to investigate practices in calculus and mechanics courses that explore the notion of derivative in one-dimensional kinematics. In particular, we seek to pinpoint consistencies and inconsistencies between practices in both disciplines to better understand the difficulties encountered by students, and propose some recommendations.

Theoretical framework

The Anthropological Theory of the Didactic (ATD – e.g., Bosch et al., 2020) provides useful tools to study practices in calculus and mechanics; these fields may be considered as being two different *institutions*, as defined in ATD. One of those tools is *praxeology*, which consists of two blocks: a practical block (*praxis*) and a theoretical block (*logos*). The *praxis* block contains a *type of task*, *T*,

and a *technique*, τ , to accomplish that task. The *logos* block includes the rationale, or *technology*, θ , itself supported by a wider *theory*, Θ . The *logos* block justifies and explains the *praxis* block.

Bosch et al. (2020) also specify the “institutional relativity” of *praxeologies* (p. xv). Not only can a praxeology be defined solely in relationship to an institution, but it may also evolve within the institution or move from one institution to another. In doing so, each of its four elements may undergo a degree of transformation. We are interested in these phenomena and therefore formulate our research question as: *What are the main consistencies and inconsistencies in praxeologies related to the derivative in one-dimensional kinematics in mechanics and differential calculus courses?*

Methodology

Our research question is the starting point of a large ongoing research project, whose main results are summarized in this presentation. In Quebec, Canada, colleges are post-secondary institutions that provide, among other course offerings, two-year science programs for students intending to pursue STEM-oriented university studies. We selected a large college (College A hereinafter), collecting data from three different sources: textbooks, teachers and students.

Textbooks. We conducted a praxeological analysis examining the relevant sections of five calculus and five mechanics textbooks. These included the books used by College A, as well as other textbooks widely used in Quebec (for more details, see Hitier & González-Martín, 2022a).

Teachers. We first conducted semi-structured interviews with four calculus and three mechanics teachers from College A (for more details, see Hitier & González-Martín, 2022a). We then observed two classes: one differential calculus and one mechanics course, during the winter 2021 term. The two observed teachers, who also participated in a semi-structured interview, were not among the previous participants. All participants volunteered to take part in the study.

Students. An online questionnaire containing problems in both kinematics and pure calculus contexts was distributed to science students at the end of the fall 2020 term. Among the approximately 1,200 students contacted, 62 answered at least one of the problems (for more details, see Hitier & González-Martín, 2022b). In March 2021, we conducted problem-based interviews with four student volunteers who had completed the questionnaire.

Results and discussion

In this paper, we discuss the main results of the analyses performed so far.

What we learn from the textbooks

Results of our textbooks analysis have been reported in Hitier & González-Martín (2022a). We noticed, among other elements, that in mechanics the presentation of velocity as the limit of average velocities, as the rate of change, as the slope of a tangent and as derivative appears in the *logos* of all textbooks; we also identified a few shared praxeologies. However, in the mechanics textbooks, only a small number of tasks use the derivative explicitly (for instance, tasks that ask students to determine the velocity function from a position function using a technique based on differentiation). In general, in the mechanics textbooks, “once the equations of motion are introduced, the explicit use of the derivative disappears from the proposed techniques, which take an algebraic approach” (p. 312). On

the other hand, in calculus, tasks that appear in a one-dimensional kinematic context (representing only 9.4% of the tasks in the analyzed textbook sections) “rely on the limit definition or a direct application of differentiation rules, and an explicit interpretation of the derivative as the limit of a rate of change is rarely necessary, nor is an explicit interpretation of the motion context required” (p. 312). It appears that none of the two courses actually encourages covariational reasoning, although the latter has been identified as an “underlying cognitive roo[t] for meaningful understanding of derivative” by Thompson and Harel (2021, p. 509).

What we learn from the teachers

Part of our results from the teacher interviews can be found in Hitier & González-Martín (2022a). Our participants reported that they primarily reproduce their textbooks’ praxeologies. For instance, although most of the calculus teachers consider rate of change to be important, “their teaching, [...] emphasizes computations in the techniques taught” (p. 308). Moreover, perhaps due to the fact that both courses are taught in parallel, the mechanics teachers feel that “students don’t have enough math ... to speak physics.” (p. 310) This may justify some of their practices, where derivatives occupy a very small place.

So far, the ongoing analysis of the observed courses seems to confirm that the praxeologies presented in class reflect those in the textbooks. For instance, the problems presented by the mechanics teacher are lifted from the textbook, and, in class, only one problem explicitly used the derivative. However, instead of referring to the differentiation formula (the technique provided in the solution manual), the teacher approached the problem using the limit of average velocities, probably because the derivative had not yet been covered in the calculus course.

What we learn from the students

In Hitier & González-Martín (2022a), we conjectured that the identified inconsistencies in praxeologies could be the cause of some students’ difficulties in transferring knowledge between both disciplines. To test this conjecture, we proposed, both in the questionnaire and in the interviews, pairs of “similar problems”, that is, problems presenting basically the same task, one in a pure mathematics context, the other in a kinematics context. Only a few students used praxeologies from the familiar kinematics task to solve the unfamiliar calculus task (Hitier and González-Martín, 2022b).

In the interviews, we also proposed questions without explicitly framing them in either discipline. For instance, we asked the participants what information they would need and how they would proceed to determine the maximum height of an object thrown upward, a problem found both in calculus and mechanics textbooks. All the students mentioned techniques from kinematics; that is, they asked for punctual data, such as the initial velocity, and used one or more kinematics equations to solve the problem. Two of the four students (S2 and S4) identified that “you could give me various [data] and with those various [data], I could solve it in different ways” (S4), and only S2 (whose calculus and mechanics courses were *paired*, see Hitier & González-Martín, 2022b) mentioned a technique from calculus:

I could solve it two ways: if I had three out of the five kinematics variables, then I could use the kinematics equations to determine the maximum height, or if I had the position function of this

object, then I could use the first derivative test to determine the maximum of the function. (S2)

Final remarks

Our research so far has identified that although they share a common *logos*, the praxeologies in calculus and mechanics reveal important inconsistencies, which seem to contribute to students' difficulties in making connections between both disciplines. In calculus, kinematics problems tend to be tackled by using differentiation formulas, and not explicitly considering motion or covariation; in mechanics, ready-to-use formulas are provided, so students can solve these problems without using knowledge from derivatives nor thinking in terms of covariation. Our interviews also show that the students prefer ready-to-use formulas where they do not have to reason in terms of functions or variation; it seems, therefore, that techniques learned in calculus are abandoned in favor of the ready-to-use formulas learned in mechanics. We conjectured in Hitier & González-Martín (2022a) that some inconsistencies may arise from both disciplines having different epistemological approaches; we propose that collaboration among mathematics and sciences education professionals—teachers and researchers—could help bridge this gap. We also stress the importance of including more tasks in both disciplines that favor physical and covariational reasoning, as our analysis identifies that neither calculus nor mechanics explicitly covers this crucial element. The more teachers from both disciplines collaborate to create tasks based on ideas foundational to calculus (e.g., Thompson & Harel, 2021), where techniques do not rely on the use of formulas, the more students will be able to develop conceptual learning related to one-dimensional kinematics.

References

- Biza, I., González-Martín, A. S., & Pinto, A. (2022). 'Scaffolding' or 'Filtering': A Review of Studies on the Diverse Roles of Calculus Courses for Students, Professionals and Teachers. *Int. Journal of Research in Undergraduate Mathematics Education*, 8(2), 389–418. <https://doi.org/jq4v>
- Bosch, M., Chevallard, Y., García, F. J., & Monaghan, J. (Eds.). (2020). *Working with the anthropological theory of the didactic in mathematics education: a comprehensive casebook*. Routledge. <https://doi.org/jq4w>
- Hitier, M., & González-Martín, A. S. (2022a). Derivatives and the Study of Motion at the Intersection of Calculus and Mechanics: a Praxeological Analysis of Practices at the College Level. *Int. Journal of Research in Undergraduate Mathematics Education*, 8(2), 293–317. <https://doi.org/jq4x>
- Hitier, M., & González-Martín, A. S. (2022b). "It all depends on the sign of the derivative": A praxeological analysis of the use of the derivative in similar tasks in mathematics and mechanics. In J. Hodgen, E. Geraniou, F. Ferretti, & G. Bolondi (Eds.), *Proceedings of the Twelfth Congress of European Research Society in Mathematics Education (CERME12)*. ERME / Free University of Bozen-Bolzano. <https://hal.archives-ouvertes.fr/hal-03750626>
- Hitt, F., & González-Martín, A. S. (2016). Generalization, covariation, functions, and calculus. In Á. Gutiérrez, G. C. Leder, & P. Boero (Eds.), *The Second Handbook of Research on the Psychology of Mathematics Education* (pp. 3–38). Sense Publishers. <https://doi.org/jq42>
- Thompson, P. W., & Harel, G. (2021). Ideas foundational to calculus learning and their links to students' difficulties. *ZDM—Mathematics Education*, 53(3), 507–519. <https://doi.org/gj2m8f>

A contextualised calculus unit for science students

Deborah King¹, Ava Greenwood² and Michael Jennings²

¹The University of Melbourne, Australia; dmking@unimelb.edu.au

²The University of Queensland, Australia; ava.greenwood@uq.edu.au, msj@uq.edu.au

Introduction

As Dreyfus, Kouropatov, and Ron (2021) suggest “it is hard to imagine modern scientific culture without derivatives and integrals.” (p. 679). It is broadly known by mathematicians and scientists alike that calculus is ubiquitous in all branches of science. But whilst there has been significant research interest in student transition from introductory calculus to university analysis and proof, teaching calculus for university science students has attracted little focus from mathematics education researchers.

Rationale for teaching calculus to science students / teaching approaches

The increasing role played by mathematical modelling in all areas of modern science reinforces the need for science students to have a working knowledge of calculus. However, calculus often presents major challenges affecting student persistence in STEM disciplines. This is particularly true for students from groups historically underrepresented in STEM, with longstanding concerns in the USA about the drop-out rates from university calculus units (Rasmussen & Ellis, 2013).

Traditional calculus units have inherent difficulties meeting the demands of various needs within the same class (for example, economics, science, engineering) often leading to disengagement when students do not appreciate the relevance of mathematics to their area of study. In addition, how the mathematics is transferred to a science context has not been a focus for mathematics education researchers, though recent findings by Nakakoji and Wilson (2018) suggest that transfer varies according to discipline but correlates with higher levels of general educational attainment.

How best to incorporate the teaching of calculus in science curricula is often decided on pragmatic rather than pedagogic grounds. Options include that calculus is embedded in various science units including relevant context, bespoke mathematics units designed for a specific area of science, or stand-alone mathematics subjects where little relevant context is offered. Which alternative is chosen is often decided by the space in a degree available to incorporate additional units or resource impacts like the cost of delivering specific mathematics units instead of a general mathematics unit.

The *BIO2010: Transforming Undergraduate Education for Future Research Biologists* project made recommendations including creating strong foundations in mathematics through the development of interdisciplinary subjects taught by an interdisciplinary team (National Research Council, 2003). Numerous studies, including O’Leary et al. (2021), have found that biology students taking newly designed mathematics units performed the same or better in their subsequent science units than those students who studied the traditional calculus units.

A leading Australian university has attempted to bridge the gap between teaching calculus theory and practice by designing an innovative unit for science students across a range of degrees.

Case Study: Theory and Practice in Science (SCIE1000)

In 2008, following the *BIO2010* project, a new interdisciplinary unit, *Theory and Practice in Science* (SCIE1000), was designed for a wide range of science students at The University of Queensland (UQ). The unit resulted from a strong desire by two Faculty Deans for biomedical and biology students to learn more quantitative skills. Previously, biomedical and biology students studied only one statistics unit in first-year and no mathematics units over their entire degree.

Initially, SCIE1000 was compulsory for Bachelor of Biomedical Science students and highly recommended for all other science students. By 2018 it was compulsory for all Bachelor of Science students bringing the total enrolment to approximately 1,500 students annually. The unit SCIE1000, designed by a mathematician with input from science academics, is built on four pillars: scientific thinking, modelling and analysis, programming, and communication. The content is interwoven throughout the material rather than being delivered in separate blocks. It is co-taught by mathematicians and scientists, highlighting the differences between doing mathematics as a mathematician and doing mathematics as a scientist.

SCIE1000 includes 33 case studies that examine a variety of contexts drawn from a range of scientific disciplines, including chemistry, biology, and physics. More than half of the case studies involve calculus. It is expected (but not required) that all students have previously studied an introductory calculus unit (usually at secondary school). Whilst including calculus in science contexts is not a new idea, the design of SCIE1000 is focused less on analytical skills typically covered in calculus units and more on practical applications of mathematics to elucidate the science contexts.

This practical focus is partially achieved by using numerical techniques and algorithms, which also reinforces the acquisition of programming skills. Students are empowered to solve complex, real-life equations using rates of change in Newton's method, interpret areas under curves with simple numerical integration techniques such as the trapezoidal rule, and employ Euler's method to solve ordinary differential equations (ODEs) and systems of ODEs to model populations. Accompanying these techniques is a strong emphasis on interpretation of the models and an evaluation of their applicability in context.

In SCIE1000, rates of change are introduced through the context of pharmacokinetics. This starts with laying a brief conceptual foundation of average versus instantaneous rates and establishing a connection between the sign of the derivative and the increasing and decreasing behaviour of functions. These ideas are explored in context including blood cyanide concentrations resulting from smoking (case study #17) and blood alcohol concentration curves (#18). Newton's method is introduced as a means of determining the time at which a contraceptive reduces below some minimum threshold for reliable function, where the concentration of the contraceptive is presented as a surge function which motivates the use of a numerical solution technique in the absence of an analytical solution (#19). Despite this practical approach, students encounter the derivation of the Newton's method formula, with an emphasis placed on the mathematical power of seemingly simple straight lines, namely the tangent line.

In many instances, students can also draw on their own life experiences to find relevance in the calculus concepts being taught. Calculating the area under a curve (AUC) is a topic where this is

evident. There are four case studies where the primary focus is the AUC. In the first of these (#21), students explore exposure to alcohol and consider the effects of binge drinking. Then, students encounter AUC as a tool for interpreting diagnostic measurements taken over an interval in the context of blood glucose (#22). Finally, students utilise ratios of areas in the definitions of Glycaemic Index (GI) (#23) and the bioavailability of medicine (#24). Integration is not a mathematical technique that is taught in the course, instead, students develop an elementary understanding of left and right Riemann sums and utilise the trapezoidal rule (or other appropriate approximations) to perform AUC calculations and give these calculated quantities meaning. The AUC case studies are rooted in biomedical contexts, but many students would be able to contextualise these ideas through their own lived experience and continue to utilise this knowledge as informed consumers of goods and services.

The final calculus topic encountered in this course, differential equations, is likely new for many students and could be perceived as mathematically daunting if not handled carefully. Students are provided with foundational tools which enable them to understand, develop, and numerically solve simple ODE models they may encounter in their own discipline area, and show why DEs can be a valid and useful approach in practice. Classic ODEs describing exponential growth, logistic growth, predator-prey interactions, and SIR(D) models of infectious diseases are all encountered in this unit. These concepts are uncovered through case studies including monitoring bacterial growth of *E. coli* in food handling (#25), examining overfishing of oysters and maximum sustainable yields (#27), evaluating interventions for reversing population decline among turtles (#28), and investigating potential impacts of vaccinations on disease spread dynamics and “flattening the curve” (#32) which has been particularly topical since the advent of the Covid-19 pandemic. Although the study of DEs in SCIE1000 does not touch on analytical solution techniques which may be covered in more traditional calculus units, emphasis is again placed on demonstrating that the tangent line can be thoughtfully utilised to approximate a solution profile through Euler’s method. Consequently, students should leave with a reasonably comprehensive DE modelling toolkit given that the unit is typically taken in the first semester of study at university.

A 2008 survey of biological science students taking SCIE1000 found that students held a positive view of the importance of mathematics in science and Matthews, Adams, and Goos (2010) concluded that “Further comparisons between 2008 and 2009 demonstrated the positive effect of using genuine, real-world contexts to enhance student perceptions toward the relevance of mathematics” (p. 290). A later 2019 study found that although SCIE1000 students had an overall favourable perception of mathematics at the end of the semester, an examination of the change in student attitudes towards mathematics from the beginning of the semester to the final week of study suggested the course may have a mixed effect on student’s views towards using and doing mathematics (Piggott et al., 2019).

More research is clearly needed for SCIE1000 to determine how effective this ‘calculus in context’ approach is in terms of improving student perceptions of mathematics. Whilst the aim of SCIE1000 is not to teach calculus in a traditional manner, an area of future research could be to investigate SCIE1000 students’ calculus understanding when attempting more traditional calculus questions.

There has been uptake of several SCIE1000 case studies in traditional calculus units at UQ. For example, the BAC case studies (#18, 21) have been used in two ways: to illustrate how calculus underpins everyday situations, and to determine students’ conceptual understanding of differentiation

and the threshold concept of functions. For example, differentiating the Posey and Mozayani formula (2007) for BAC $B(t) = \frac{A}{rW}(1 - e^{-kt}) \times 100 - Vt$ is arguably a much richer exercise than differentiating, for example, $y = 5e^{-2t} - 5t$, due to the multiple ‘letters’ in the equation. Conversations with students in these traditional calculus units have shown that students appreciate seeing where calculus is used in everyday situations, particularly regarding alcohol as many Australian students become legally able to consume alcohol in their first year of university.

Conclusion

Understanding calculus is a fundamental skill required by a diverse group of graduates including scientists and engineers. In spite of this, there is a lack of research on how theoretical knowledge is transferred to a variety of scientific contexts. Such evidence is critical in influencing decision makers to prioritise pedagogic concerns when designing teaching models over resourcing issues when effective models are more costly.

The first-year science unit presented here is just one example of teaching calculus to science students that improves student engagement when an authentic situation is employed; that is, when mathematicians and scientists work collaboratively rather than in isolation.

References

- Dreyfus, T., Kouropatov, A., & Ron, G. (2021). Research as a resource in a high-school calculus curriculum. *ZDM*, 53(3), 679–693.
- Matthews, K., Adams, P., & Goos, M. (2010). Using the principles of BIO2010 to develop an introductory, interdisciplinary course for biology students. *CBE–Life Sciences Education*, 9(3), 290–297.
- Nakakoji, Y. & Wilson, R. (2018). First-Year mathematics and its application to science: Evidence of transfer of learning to Physics and Engineering. *Education Sciences*, 8(1), 8–23.
- National Research Council. (2003). *Bio 2010: Transforming undergraduate biology education for future research biologists*. Washington, DC: National Academies Press. <https://doi.org/10.17226/10497>
- O’Leary, E., Sayson, H., Shapiro, C., Garfinkel, A., Conley, W., Levis-Fitzgerald, M., Eagan, M., & Van Valkenburgh, B. (2021). Reimagining the Introductory Math Curriculum for Life Sciences Students. *CBE–Life Sciences Education*, 20(4), 1–20.
- Piggott, A., Herke, S., McIntyre, T., & Bulmer, M. (2019). The effect of an interdisciplinary science course on student perceptions of computer programming. Australian Conference on Science and Mathematics Education 2019, Sydney, Australia, 2-4 October 2019. Open Journal Systems.
- Posey, D., & Mozayani, A. (2007). The estimation of blood alcohol concentration: Widmark revisited. *Forensic science, medicine, and pathology*, 3(1), 33-39.
- Rasmussen, C., & Ellis, J. (2013). Who is switching out of calculus and why? In A. M. Lindmeier & A. Heinze (Eds.), *Proceedings of the 37th Conference of the International Group for the Psychology of Mathematics Education*, 4 (pp. 73–80). Kiel, Germany: PME.

The use of integrals for accumulation and mean values in basic electrical engineering courses

Jörg Kortemeyer¹ and Rolf Biehler²

¹Clausthal University of Technology, Germany; joerg.kortemeyer@tu-clausthal.de

²Paderborn University, Germany; biehler@math.upb.de

Introduction

This paper deals with the use of integrals in a task on signal analysis given to students in an examination in a first-year course on electrical engineering (EE). In this task, the students are to calculate several mean values of voltages required to describe the behavior of electrical networks using a voltmeter. We aim at understanding what kind of mathematics is required for the solution and how it is used. We used this task in a larger empirical study of several tasks. We interviewed experts in EE with regard to their understanding of the competencies needed to solve the task, studied pairs of students' solution processes, and analyzed written student solutions taken from the course exam. We will focus on the interview of the EE-expert, who was asked to work on the problems using the expectable knowledge of good students after their second semester. The interview was done using the PARI-methodology (Hall et al., 1995): after work on the task, the expert was asked for reasons for their decisions and actions and explicitly about the required competencies.

The task shows different practices and disparities between mathematics and engineering courses typical for such exercises. One reason for disparities is, that engineering students often learn mathematics separately from the engineering courses, which leads to several challenges. For example, the mathematics courses (MfE) have the deductive conceptual structure of mathematics lectures while the EE-course has an order of topics according to electromagnetic theories and often also according to traditions. Moreover, mathematical practices in EE can be characterized (Alpers, 2017) that differ from corresponding practices in mathematics courses, e. g., infinitely small lengths (dl), areas (dA) or volumes (dV) are treated as infinitesimally small quantities, which are cumulated by integration.

Theoretical background and methodology

For the study of EE-problems we developed a concept for a normative solution, the student-expert-solution (SES), which is a central tool for the analysis of solution processes and products based on the rather short solution for the correctors of the exam. The final step of its generation is an expert interview to find out the competencies and skills expected from students when solving the exercises, for more details, see Kortemeyer and Biehler (2022). We found that solution processes in EE-problems can be subdivided into three phases based on conceptualizations of modeling processes by Uhden et al. (2012) and problem-solving and heuristics by Polya (1949): Phase 1 (mathematization) is usually done with help of a conventionalized model, i.e., students do not make their own idealizations and simplifications. In Phase 2 (math-electrotechnical symbolic-conceptual manipulation and reasoning) students enter a world of physical quantities (numbers with units) and

use mathematical knowledge to obtain their solution. Phase 3 (validation) contains a critical review of the results in the EE-context, but not a check of the adequacy of the model.

With regard to the integral concept, we distinguish between different interpretations or mental models: (oriented) area, accumulation, mean value (average) (Greefrath et al, 2021) and of course the mathematical property of average, which are relevant at school level.

The use of integrals in the EE course and students' prior knowledge

Considering prior knowledge, students should be rather familiar with both antiderivative and orientated area conceptions of the integral. The lecture notes of the EE-course provide formulas that usually are developed by using differentials and the accumulation approach but as the derivation of the formulas are no explicit part of the lecture notes, it is not clear how and whether this was done in the EE-lecture. The lecture provides formulas calculating means of a varying quantity by an integral, without deriving them, probably assuming that the use of integrals as averages was covered in MfE, which is often not the case. We will see that the exercises focus on the application of the provided formulas but not on developing them from basic laws using the accumulation aspect of integrals.

The exercise on signal analysis

The voltage $u_L(t)$ shown in the figure is applied to a coil $L = 100\text{mH}$ for a duration of $T = 10\text{s}$:

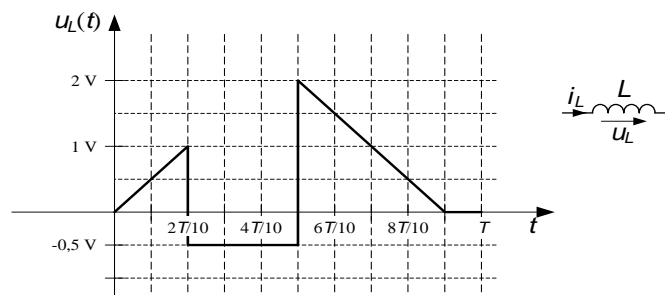

Figure 1: Given sketch of the voltage values

With the given sketch on voltage values $u_L(t)$, the students are to calculate (1) the average value, (2) the RMS-value and (3) the rectified value of the voltage in the interval 0s to 10s. Student just have to remember three respective formulas from the lecture, and then solve the integral mathematically.

$$(1) \left| \bar{u} = \frac{1}{T} \int_0^T u_L(t) dt \right|, (2) \left| u_{\text{eff}} = \sqrt{\frac{1}{T} \int_0^T u_L^2(t) dt} \right| \text{ and } (3) \left| |\bar{u}| = \frac{1}{T} \int_0^T |u_L(t)| dt \right|$$

Normative solution and expert interviews

In this section, the three parts of the exercise are analyzed parallelly, as they have many commonalities. $u_L(t)$ is a piecewise-defined function. From the MfE-course view, it would be necessary to find (interval-wise) formulas for the function sketched in figure 1 and then calculate the integrals in the four intervals and use the additivity theorem of the integral to calculate the integral for the whole interval from 0 to T. This calculation is situated in phase 2, students have to

work with quantities and their units (different from MfE). Also, the formulas for the function (phase 1) in the four intervals have to be specified with units, functions have to be regarded as functions between magnitudes not between sets of numbers as in MfE. For example, in the interval from $5T/10$ to $9T/10$, the correct formula is $u_L(t)=4,5V-1V/s \cdot t$. t has the unit s, so that $u_L(t)$ has the unit V (volt). Students are required to use their school knowledge to specify the formula for the different linear or constant functions in other intervals. However, in school, setting up such formulas with units was not practiced. From these formulas, just the square or absolute values must be taken in (2) resp. (3). These leads to elementary functions, where the integral can be calculated from the antiderivative point of view.

However, the expert suggests a different solution: He uses the area interpretation not just as an interpretation (as often in schools) but as a calculation method. The oriented area under the curve in figure 1 can be calculated by elementary geometric area formulas. It is moreover allowed to cut and reassemble parts while the size of the area remains invariant. To calculate the average, the expert used a technique he calls “block shoving” instead. After writing down formula (1) he says: "That means we now want to calculate the two areas under here." He hatches both triangles, separates the apex ($u_L(t)>0.5V$) from the front triangle, and moves it so that a rectangle with height 0.5V is obtained, which can be calculated as $0.5V \cdot 2s = 1Vs$. He continues with regard to the interval from "0.5V times 3s is -1.5Vs. And here [meaning the interval between $5T/10$ and $9T/10$] we can shove blocks again. 1V times 4s are 4Vs. A total of 3.5. Second cancels out [he means the division by T in formula (1)], that's 0.35V." The area has the dimension V·s that is not only the dimension of magnetic flux but can be interpreted as the magnetic flux between 0 and T. The average \bar{u} is the fictious constant voltage that is needed to achieve the same magnetic flux as the signal shown in figure 1. In geometrical terms: The rectangle from 0 to T with the height of \bar{u} has the same area as the oriented area under the signal function in figure 1. This interpretation is not made explicit but underlies implicitly the calculation.

This strategy uses a combination of two conceptions of an integral: on the one hand, the integral itself gives the orientated area between the t -axis and the graph of the function, and on the other hand, the formula applied in (1) gives the mean of the cumulative values of $u_L(t)$ in the interval of integration. The cumulative conception of the integral is needed for the derivation of the formula, but it is not needed for the calculation. Instead, the expert substitutes the integral by a sum of areas of geometric objects which can be calculated by known formulas without applying calculus.

Concerning the calculation of (2), the expert states “Things are a bit more complicated because you have a square and a root in there. The square makes life a bit difficult. If you have a constant value, you square it and you can still calculate it with the rectangles. With triangles it is different, because they become parabolas by squaring. It is not possible to calculate the area in one go. You really have to calculate the integral. You have to do this piece by piece, but you can move the blocks back and forth as you like, which is what I did here. That's why the lower limits are all zero. This eliminates terms, which makes it easier.” The expert says, that there is no possibility of avoiding integration in this part, but he tries to simplify this integration as much as possible by the “moving block” technique again. He shifts the function of rectangle in the interval from $2T/10$ to $5T/10$ and that of the triangle in the interval $5T/10$ to $9T/10$) along the t -axis to make zero the lower limit of all

integrations, which affects both the upper limit of integration and the formula of the functions in the integrand. It makes evaluating the integrals easier, as zero can be inserted for the lower limit in each case, and the formulas of the linear functions are also somewhat easier to find.

In (3) - using the block-conception again - all blocks have now a positive sign because of the absolute value – but the areas that were calculated in (1) can be reused, giving 0.65V instead of 0.35V as the result. In his validation, the expert argues that the value has to be greater than in task (1), as all the blocks have to be taken positively. This can be even considered as a generic geometric proof that the integral over the absolute value is always equal or higher than the integral itself. This is a very different kind of justification than the proof in MfE, where the monotonicity of the integral is used for justification and such geometrical arguments would usually not be accepted.

Summary and recommendations

This paper presents an exercise on signal analysis in which integration is used to calculate different means of a process where the voltage varies. We identified several differences between the practices in MfE and EE. The calculation of the integral is done or simplified by geometrical formula and operations, based on a clear understanding of integral as an oriented area. The area and the average have units with a physical meaning. This is surprising as one might have expected that the accumulation aspect of the integral might be the most important in physics and EE. Its relevance is high in the derivation of the formulas, however the exercise in this examination does not check a competence of deriving and interpreting formula but just of applying formula to a situation. Moreover, the average interpretation of integration is also most relevant, which however, as a rule has neither a prominent role in school calculus nor in MfE courses. These differences if prevailing could lead to changes in both courses for a better co-ordination.

References

Alpers, B. (2017). Differences between the usage of mathematical concepts in engineering statics and engineering mathematics education. In: Göller, R., Biehler, R., Hochmuth, R., & Rück, H.-G. (Eds.). (2017). *Didactics of Mathematics in Higher Education as a Scientific Discipline – Conference Proceedings*. (pp.138–142). Universitätsbibliothek Kassel URL: nbn:de:hebis:34-2016041950121

Greefrath, G., Oldenburg, R., Siller, H.-S., Ulm, V., & Weigand, H.-G. (2021). Basic mental models of integrals: theoretical conception, development of a test instrument, and first results. *ZDM – Mathematics Education*, 53(3), 649-661. <https://doi.org/10.1007/s11858-020-01207-0>

Hall, E. P., Gott, S. P., und Pokorny, R. A. (1995). A procedural guide to cognitive task analysis: The PARI Methodology (No. AL/HR-TR-1995-0108). <http://www.dtic.mil/dtic/tr/fulltext/u2/a303654.pdf>. Armstrong Lab Brooks AFB TX Human Resources Directorate.

Kortemeyer, J., & Biehler, R. (2022). Analyzing the interface between mathematics and engineering in basic engineering courses. In Biehler, R., Liebendörfer, M., Gueudet, G.,

Rasmussen, C., & Winsløw, C. (Eds.). *Practice-Oriented Research in Tertiary Mathematics Education* (pp. 669-692). Springer Spektrum. DOI: [10.1007/978-3-031-14175-1_32](https://doi.org/10.1007/978-3-031-14175-1_32)

Polya, G. (1949). *How to solve it: A new aspect of mathematical method*. Princeton University Press.

Uhden, O., Karam, R., Pietrocola, M., & Pospiech, G. (2012). Modeling mathematical reasoning in physics education. *Science & Education*, 21(4), 485-506. DOI: [10.1007/s11191-011-9396-6](https://doi.org/10.1007/s11191-011-9396-6)

The transition between mathematics and microeconomics: introduction to Lagrange's method

Ida Maria Landgärds

University of Agder, Norway; ida.landgards@uia.no

Introduction and embedding of the research

Most studies in mainstream peer-reviewed journals in economics include formal mathematically or statistically based analysis (Dawson, 2014). In particular, calculus plays an important part in the economics discipline in higher education and has a key role in developing understanding of key economic principles and concepts.

Although economics students are usually required to take a mathematics course in their first year, the literature shows that many students struggle to make sense of the mathematics in other economics courses (Feudel & Biehler, 2021). From the literature on service mathematics courses (Alpers, 2020), it is clear that discrepancies between how mathematical concepts are understood and taught in mathematics compared to the way they are used in other disciplines cause learning problems for many students. There are few studies investigating such discrepancies in economics, but for example, Feudel and Biehler (2021) found that most economics students could not make the connection between the mathematical concept of the derivative and the common economic interpretation of the derivative.

Similarly, the motivation for this paper emerged from a meeting with two professors at the business school of the University of Agder where they raised deep concern about many of their students seeming to be unable to apply the Lagrange multiplier method. This gave me, as the lecturer of the mathematics for economists students course, the challenge of understanding how such discrepancy might be causing learning difficulties for the students. While Xhonneux and Henry (2011) analysed presentation of Lagrange's theorem aimed specifically at students studying economics and at students specializing in mathematics, this study investigates the presentation and use of Lagrange presented in two texts aimed at the same audience, that is, the economics students. The aim here, is to gain insight into how the concept is used in economics so as to make the teaching of the economics service mathematics course more relevant for students.

Lagrange's multiplier method

Lagrange's Multiplier method is used to solve constrained optimization problems in economics, particularly in microeconomics. The method provides a strategy for converting constrained optimization problems (finding the maximum or minimum of a function of several variables subject to equality constraints) into unconstrained optimization problems, by introducing a new variable λ , called the Lagrange multiplier.

Methodology

I investigated the introduction of the Lagrange multiplier method through analysis of the textbooks which are the main teaching and study resource in the respective courses at the University of Agder (and at several other universities in Norway): "Matematikk for økonomistudenter" by Dovland and Pettersen (2019) and "Microeconomics with Calculus" by Perloff (2013). Ideally, the

mathematics for economics students course (taught in the students' second semester) should provide solid understanding of the method which is later used in the microeconomics course (taught in the students' third semester). Thus, given that students use the textbook as an important learning tool (Randahl & Grevholm, 2010), they need to deal with the transition from the mathematics textbook to the microeconomics textbook. To prepare to carry out this textbook analysis, I read several important studies which guided my work (i.e. Feudel, 2019; Randahl & Grevholm, 2010). My research question was: How do the concepts used to introduce Lagrange's method compare between the mathematics for economists textbook and the microeconomics textbook? To answer the question, I focused on key terms used in each text and examined the relationship between them that students need to establish in order to make the transition.

The graphical approach to constrained optimization

The analysis started with an exploration of the chapters in the microeconomics book where Lagrange's multiplier method was mentioned and used. The focus for this paper was then restricted to the first encounter with Lagrange's method, which considers constrained consumer choices. In the mathematics book, Lagrange's multiplier method is introduced in a chapter which considers constrained optimization problems. At a first exploration of the structure of the chapters, I noticed respects in which the two books followed similar approaches. First constrained optimization is approached graphically, then by the substitution method, and finally introducing Lagrange's multiplier method. However, a closer look at the introduction and the solved problems (examples) to the three stages revealed important differences between the two books. Within the space available here, I choose to focus on the first stage of the introduction, that is, the graphical introduction to constrained optimization. In the mathematics text, the key-terms were: maximum, minimum, contour line and tangent point whereas in the microeconomics text the key terms were: indifference curve, utility function, optimal bundle, marginal rate of substitution, marginal rate of transformation and tangent. These are outlined shortly in this section and the graphs discussed are presented in Figure 1 and 2 respectively.

In the mathematics book, constrained optimization problems are informally introduced through the analogy of a landscape with a mountain where the constraint is the road you are restricted to move along when moving by car in the landscape. Landscapes can be plotted in the xy -plane by drawing contour lines. It is discussed that a road crossing a contour line on a map is not at a maximum or minimum of the landscape accessible by car. The 'pictorial map-introduction' is simultaneously discussed in mathematical terms around the example:

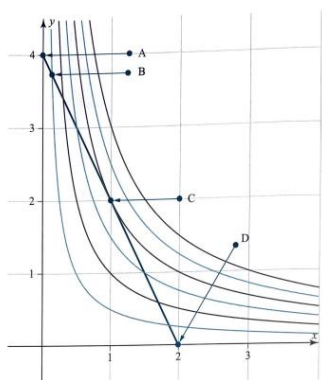

Figure 1: Graph from (Dovland & Pettersen, 2015 p. 506)

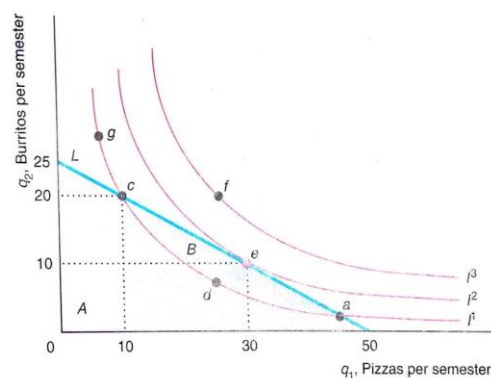

Figure 2: Graph from (Perloff, 2013 p. 101)

Maximize/minimize $f(x, y) = xy$ s.t. $2x + y = 4$, $x, y \geq 0$. The graph (presented in figure 1) is derived through plotting several contour lines of $z = 0.5, 1, \dots, 3$. The maximum and minimum values are then discussed by counting the values of the different intersection points of the objective function. The constraint's intersection with the x - and y -axis (point A and D) are pointed out as minimizing the value of the function. While the intersection with the contour lines (point B) cannot be the maximum points, the maximum must be where the constraint is tangent to a contour line (point C) or alternatively, the curve defining the constraint is itself going through a critical point of the objective function f . The second alternative is easily rejected as the constraint is not going through the origin, which is the critical point of f . The conclusion is henceforth, that the only remaining alternative to the maximum is the tangent point C .

In the microeconomics book, the context is consumer choices subject to budget constraint. Consumer preferences are mapped as indifference curves with the underlying assumptions that the consumer chooses between two goods only (pizzas (q_1) and burritos (q_2)), uses up the whole budget and maximizes his/her utility. All points (bundles of goods) on an indifference curve make the consumer equally satisfied but shifting between indifference curves changes the level of satisfaction (or utility).

First, presumably because consumers seek to maximize their well-being, minimizing utility is not an issue. The maximum point is discussed as lying within the opportunity set (the area $A + B$). Because of consumers always preferring more to less the consumer will not purchase a bundle inside the area (point e is preferred to d as it gives the consumer more of both goods and can be purchased within the budget). Points c and a lie on the budget line but will not be preferred to e , since e lies on a higher indifference curve and hence, gives higher utility to the consumer. The conclusion, called the: "highest indifference curve rule" is hence (p.101): "The optimal bundle is on the highest indifference curve that touches the budget line." Furthermore, the 'touching' point is discussed in terms of the two curves being tangent to each other as they have the same slope at the point. The slope of the indifference curve is the Marginal Rate of Substitution (MRS), and the slope of the constraint is similarly the Marginal Rate of Transformation (MRT) of the constraint and is given by $MRT = -p_1/p_2$. Hence, at the optimal bundle point (or the point where utility is maximized) is given by $MRS = dq_2/dq_1 = -p_1/p_2 = MRT$ which rearranged gives the formula $dq_1/p_1 = dq_2/p_2$. The formula shows that the last dollar the consumer spends on good 1 gets him/her as much extra utility as an extra dollar spent on good 2, so the consumer cannot increase satisfaction by spending more on either of the goods, which is because it is the point maximizing utility.

Transition

The short presentation here already shows that, although the two texts employ fundamentally similar graphs, they differ in the language that is used to describe and explain them (not just in the type of situation that the graphs are representing). The relationship between the contour line understanding of constrained optimization and the indifference and utility curve understanding is one part of the transition that students must establish. The context in the mathematics book is formal mathematical calculation exemplified through (with graphical digital tools) formally drawn graphs (3d and 2d), which gives the student the possibility to reproduce the graphs and verify the calculations him/herself. The focus is on understanding the situation from a three-dimensional perspective discussed through the plot on the xy -plane. The graph in the economics book is more of a 'thinking-tool' used to support the verbal explanations of the economics concepts, and hence the utility function is not

explicitly given. Instead of seeing the graphs as a three-dimensional plot on the xy -plane, the students are directed to think about the level curves as bundles of goods making the consumer equally happy (indifference curves). The students are directed to think about ‘moving along’ the curve leading to equal satisfaction and ‘shifting to another curve’ meaning less or increased satisfaction (utility), while the budget constraint is fixed and out of the consumer’s control.

In the mathematics text, the key idea of maximum point being the tangent point is verified concretely, by examining the values the objective function at the different intersection points of the graph. In the microeconomics text, the point maximizing utility, the optimal bundle is first discussed from the consumer maximization perspective and then theorised through the concepts of marginal rate of substitution and marginal rate of transformation. Students thus, have to make the transition from the mathematical understanding of finding the maximum as finding the points of the constraint that give the greatest value of the objective function, to the microeconomics understanding, which is that a consumer maximizes his/her utility at the point where the slope of the indifference curve is the same as the slope of the constraint, so that the curve is tangent to the constraint, which is where $MRS = MRT$.

Conclusion

Within the space available here, I could only introduce how the concepts used in the introductory part to Lagrange’s method differed, but equally there are important differences in the transition of the other parts of the introduction to Lagrange’s method. Although the type of comparison that was made in our study and Xhonneux & Henry (2011), differed in target texts, audience and mode of analysis, our findings reinforce the point that Lagrange’s theorem is treated very differently according to the mathematics and the economics disciplines. The transition which is expected of the student between these books is demanding and perhaps signals the need for re-writing the mathematics textbook in terms of being more relevant for the economics ways of thinking about Lagrange’s theorem.

References

- Alpers, B. (2020). *Mathematics as a service subject at the tertiary level. A state-of-the-art report for the Mathematics Interest Group*. European Society for Engineering Education (SEFI). Brussels, Belgium.
- Dawson, P. (2014). *Skills in Mathematics and Statistics in Economics and tackling transition*. The Higher Education Academy.
- Dovland, O. G. & Pettersen, P. (2019). *Matematikk for økonomistudenter* (3rd. ed.). Fagbokforlaget.
- Feudel, F. (2019). Required knowledge of the derivative in economics: Results from a textbook analysis. *Proceedings of the Calculus in upper secondary and beginning university mathematics*, Norway, Kristiansand.
- Feudel, F., & Biehler, R. (2021). Students’ Understanding of the Economic Interpretation of the Derivative in the Context of Marginal Cost. *International Journal of Research in Undergraduate Mathematics Education*, 8, 1-32.
- Perloff, J. (2013). *Microeconomics with Calculus*, Global Edition (3rd ed.). Pearson Education UK.
- Randahl, M., & Grevholm, B. (2010). Learning opportunities offered by a classical calculus textbook. *Nordic Studies in Mathematics Education*, 15(2), 5-27.
- Xhonneux, S., & Henry, V. (2011). A didactic survey of the main characteristics of Lagrange’s theorem in mathematics and in economics. *CERME7 Proceedings*. Rzeszow, Poland.

Is the physicist a mathematician that takes care of reality and mathematician a physicist that cares for reals? The case of the falling and bouncing ball

Thomas Lecorre¹ and Imène Ghedamsi¹

¹CY Cergy Paris University, France; thomas.lecorre@cyu.fr; ighedamsi@yahoo.fr

Mathematicians and physicists: a context of ontological divorce?

Mathematicians and physicists have always worked together, and sometimes had both statuses. Mathematics are not only tools for physics since it sometimes generates physical entities long time before it had been observed, and physics is not only a field of application for mathematics, since it is an infinite space of inspiration and experimentation for mathematics. For instance, when the mathematical theory was not yet developed but mathematical procedures were already proposed, physics' experimentations played a crucial role in determining the effectiveness of those procedures which then would be theorized (Visser, 2018). This was, for example, the case of calculus and infinitesimal procedures when both physicists and mathematicians agreed on why do such calculations may work (Garber, 1999). At the end of the nineteenth century, real numbers were submitted to logical constraints far away from physical concerns and their formalization signed an ontological gap between the two disciplines. The foundational work of Bourbaki's group in the mid-1930s represents probably the apogee of that ontological divorce which led objects including real numbers that were shared by both disciplines not to have the same nature anymore (Plotnitsky, 2020). At the end of the seventies this separation started to reverse since theoretical physicists (re)discovered the power of abstract mathematics (Urquhart, 2008). Yet in spite of this renewed interactions between the two communities, physicists' methods of calculation do not achieve the "rigor" expected by the mathematicians (Davey, 2003).

This paper is a preliminary report on an ongoing research project that aims to explore mathematicians and physicists' ways to cope with calculations involving real numbers. In this paper, we focus on the particular case of a bouncing ball and the use of real numbers to grasp its "reality". It is acknowledged that Mathematics is broadly used in both the teaching and practices of physics. Many studies have highlighted differences in how the two disciplines use and interpret the mathematical objects. Redish et al. (2015) have stressed the need for more investigation of the meaning given by both disciplines to the same mathematical object. The aim of this paper is to initiate such investigation in the case of real numbers through the bouncing ball phenomenon by addressing the following questions: How to make clear the meaning given by physicists and mathematicians to real numbers in the bouncing ball phenomenon? Are they aware of the differences in these meanings, if any? If yes, how do they deal with in their teaching and scholarly practices?

Reals and physics in the bouncing ball phenomenon

When one study the throw of a ball; one has to know that the dynamic of the ball is a determinist phenomenon shaped by its initial conditions (height and speed). In order to mathematize the problem, physicists usually have to ask this question: What are the forces applying on the ball just

after the throw? The underlined expression permits to use Newton's law of motion when weight is the only force that determines the dynamic of the ball, whereas in $t = 0$ (the time of the throw), the force of the hand also holds. For a physicist, this expression is meaningful because it has a physical reality. For a mathematician, if $t = 0$ stands for the time of throw, "just after the throw" corresponds to no time. More precisely, if t is the time "just after the throw" then $t/2$ is also just after the throw, and this expression (or expressions such as "immediately before the collision with the ground" in De Luca, 2021) is no more meaningful in the model of real numbers because of their density. Using Newton's law of motion (the acceleration equals the sum of the forces at stake), the answer to the physic problem is purely mathematic: $x'' = mg$ where x is the position of the ball, m its mass, g the constant of gravity and x'' the acceleration. Then $x' = mgt + k$, and $x = 1/2mgt^2 + kt + h$, and initial conditions ($t = 0, x' = V_0$) are used to determine constants k and h .

In the case of a bouncing ball, physicists use the bounce coefficient to determine the ratio between the successive heights when the ball hits the floor. For instance, we suppose that the ball is bouncing exactly to the half of its height, any other coefficient will give the same answer to the central question: does it stop of bouncing or not? From the equations above we can calculate the time of falling, the time of each bounce and then we can get the total time of bouncing which is a convergent geometric series: the ball is bouncing an infinite number of times in a finite time (De Luca, 2021). There are no more Zeno's of Elea paradoxes for mathematicians since they have been solved a long time ago when real numbers and limit were formalized. For physicists the mathematical calculation remains problematic because they have to determine its consistency regarding the observed reality. This reality does not behave as reals do: if the time of bouncing is consistent with experimental measures, the number of bounces seems to be finite and heights become too small to be measured. Physicists are also not so keen on tolerating infinity. While they agree with the finitude of bounces by means of the limit process, they argue for a finite number of bounces by cutting the tail of the process using several arguments. One common argument is related to the precision of the height under which they decide that there is no more bounce. However, even reality is not so obvious to get since many factors are involved in the outcome of the bouncing ball phenomenon's measures. For example, when one has to find the bounce coefficient, studies show that to measure it using the sound method, particles have to be very slightly deviated from the mathematical sphere (Heckel et al. 2016). Reality of the phenomenon differs of the theory because of tiny differences in experimental conditions and in method of measurements. According to physicists, whatever the nature of numbers that shape reality, we can only catch decimals from it. Thus, differences between reality and limit model are definitively buried in experimental precisions (De Lucas, 2020).

The bouncing ball phenomenon constitutes a shared problem where both disciplines are at stake and specificities in dealing with (real) numbers appear as obvious. This preliminary study intends to identify the clues of mathematicians and physicists' common culture and disparities in the use of reals to grasp the bouncing ball reality.

An overview of the method

As stated by the literature, both mathematicians and physicists seem to be aware of the bouncing ball phenomenon and both use limit process to determine the time of bouncing. Yet, while mathematicians do not see any more paradox, physicists feel always the need to give arguments to eliminate it. However, the relationship between differences in mathematical meaning and the current situation is an issue still relevant in the literature. To learn more about this issue, our experiment draws on data obtained from two open questions given to three French mathematicians and three French physicists. We seek to understand how these scholars may deal with the bouncing ball phenomenon in their teaching and scholarly practices. For that, we made the choice to clearly underline key literature results about this phenomenon before giving the questions. Our aim is to provoke the need to justify one's choices as well as their interpretations. The preliminary discourse of the researcher was structured as follows: the context of the bouncing ball, the way it is usually solved with the laws of Newton and the paradox that emerges are explained. It is also explained that mathematicians are using the properties of reals to evaluate the time of bouncing using an infinite number of bounces and physicists usually use the concept of precision (the height of bouncing is lower bounded) to limit the number of bounces. Two open questions are then asked about the explained situation: 1) To what extent does this situation cause discomfort in your research practices? 2) How do you manage this situation in your teaching practices?

Preliminary results

Except one physicist who declare not to be ready to answer questions about this phenomenon which is neither his domain of research nor his domain of teaching, all the answers of physicists and mathematicians show a good knowing of it. The incapacity of one physicist to interact with our discourse and questions shows: 1) not all physicists are aware of the bouncing ball phenomenon even though it is a paradigmatic case of physicist practices with infinitesimal calculations; 2) not all physicists seem to have faced the complexity of this case in their own university specialized studies.

While the three mathematicians agree with the researcher preliminary discourse about mathematical calculations for both disciplines, the two other physicists react unexpectedly to it. Despite their agreement with the finitude of the number of bounces according to the "reality", the physicists argue differently to express their disagreement with the researcher discourse.

More precisely, one physicist believes that an infinite sum of times gives necessary an infinite time and that the time of bounces is only obtained by a limit since it is too hard to calculate all of the terms that fit a certain given precision. His explanations are mathematically contradictory since he accepts the use of the limit for pragmatic reasons but refuse the possibility of the finitude of the result of an infinite process. The other physicist rejects the possibility of an infinity of bounces since a certain force of Van der Waals is at stake and stuck the ball to the ground after a finite number of bounces (Falcon et al., 1998). According to this force, there is in fact a finite number of bounces and it is not a matter of precision or measurement. So, he does not feel any differences between mathematics and physics: when using the same models, they get the same results. This explanation is also mathematically contradictory since in one hand he refuses absolutely the

possibility of the infinite number of bounces ("we know that it is finite, one just has to try") and in the other hand he accepts to use, in the same way as mathematicians, models implying infinity.

A significant part of mathematicians and physicists' answers does not tackle the two questions and remains at the level of discussion of the researcher's preliminary discourse. This prevented to deepen the study of the impact of mathematical meanings on physicists' interpretations of the phenomenon. However, almost all physicists and mathematicians notice the differences between the two disciplines and express the crucial need to address this issue and take into account students' learnings requirements. They notice the benefit of working together as a teacher in order to facilitate the communication between the two disciplines. Mathematicians have specifically stressed the richness of the bouncing ball phenomenon and the necessity to guide students towards a better management of differences across the two disciplines.

These preliminary results show stability in mathematicians' explanation of the phenomenon and disparities among physicists' answers. While both physicists agree that the mathematical model is not reality, their interpretation of this model is quite different. Particularly, they don't seem to share the same epistemology regarding the mathematization of the bouncing ball phenomenon. The sample used in this study is very small; further investigation is needed for considering issues surrounding the question of the applicability of mathematics to the bouncing ball reality and vice versa.

References

- Davey, K. (2003). Is mathematical rigour necessary in physics? *British Journal for the Philosophy of Science*, 54, 439–463.
- De Luca, R., Di Mauro, M., & Naddeo, N. (2021) Bounces of a marble and Zeno's paradox. *Journal of Physics: Conference Series* 1929.
- De Luca, R., Di Mauro, M., Naddeo, N., Onorato, P., & Rosi, T. (2020). Achilles overtakes the turtle: experiments and theory addressing students' difficulties with infinite processes. *Physics Education*, 55 (3), 035010 DOI 10.1088/1361-6552/ab6eb3
- Falcon, E., Laroche, C., & Fauve, S. (1998) Behavior of one inelastic ball bouncing repeatedly off the ground. *The European Physical Journal B*, 3, 45–57
- Garber, E. (1999). *The Language of Physics: The Calculus and the development of Theoretical Physics in Europe*. Springer Science & Business Media, (399p.).
- Heckel, M., Glielmo, A., Gunkelmann, N., & Pösche, T. (2016). Can we obtain the coefficient of restitution from the sound of a bouncing ball? *Physics Review*, E 93, 032901.
- Plotnitsky, A. (2020). The Ghost and the Spirit of Pythagoras. In Sriraman, B. (ed), *Handbook of the History and Philosophy of Mathematical Practice*. Springer, Cham. https://doi.org/10.1007/978-3-030-19071-2_7-1
- Redish, E.F., & Kuo, E. (2015). Language of Physics, Language of Math: Disciplinary Culture and Dynamic Epistemology. *Sci & Educ*, 24, 561–590.

Urquhart, A. (2008), The boundary between Mathematics and physics. In Mancosu P. (ed.), *The Philosophy of Mathematical Practice* (online edn, Oxford Academic), <https://doi.org/10.1093/acprof:oso/9780199296453.003.0016>

Visser, M. (2018) The utterly prosaic connection between Physics and Mathematics. *Philosophies*, 3(4), 25.

“I forget about math when I go to physics”

Henry Taylor and Michael Loverude

California State University Fullerton, United States; mloverude@fullerton.edu

Introduction

This work is part of an ongoing collaboration to investigate student learning and application of mathematics in the context of physics courses. Our project seeks to study student conceptual understanding of the mathematics encountered in physics courses, to investigate models of transfer, and to develop instructional interventions to assist student learning.

The mathematical function is a concept that pervades much of introductory mathematics and physics instruction. There is an extensive body of published research on student conceptions of functions in the Research in Undergraduate Math Education (RUME) community (Carlson 1998, . Despite this focus, the corresponding work in Physics Education Research (PER) has generally not explicitly attended to the function concept. The PER community has extensively studied student learning of one-dimensional kinematics in the context of position and velocity graphs [8-9], but very little of this work reflects understanding of related work in the math education community. A goal is to unite RUME and PER work on student understanding of the function in kinematics.

Theoretical Perspective

A prior analysis (Taylor & Loverude 2019) used the lens of conceptual blending (Fauconnier & Turner 2002). Blending posits that human knowledge is pervaded by metaphors constructed from bodily experiences, with knowledge activated at appropriate moments. In the blending framework, these resource groups are termed *mental spaces*. Bing and Redish (2009) and others have used blending to examine how students use mathematics in physics contexts.

For this portion of the study, we have instead chosen to examine responses through the lens of transfer. Standard models of transfer presume decontextualized and portable knowledge. Differences between the context in which an idea was originally learned and a later problem are interpreted as “surface features.” Course prerequisites reflect such an understanding of transfer. For example, the expectation is that students learn derivatives in math, and then employ the well-understood tool of derivatives in physics problems.

Several studies have used transfer to examine student use of mathematics in physics. Cui et al (2006) reported on a series of tasks in which students were given isomorphic physics and mathematics questions involving integration. While students could execute acontextual integrals, most had difficulty setting up and evaluating relevant integrals in physics contexts; tasks perceived as simple transfer by experts were in fact challenging for students.

This classical transfer model has been reexamined by several scholars, and our analysis is influenced by Lobato’s actor-oriented transfer and Wagner’s transfer-in-pieces. Lobato described studies of transfer considering the perspective of the learner, social situation, and context (Lobato 2012). Transfer-in-pieces suggests that knowledge is highly context-sensitive, and that mathematical ideas perceived as experts as being “the same” require different supporting knowledge to be used in new contexts (Wagner 2006). New contexts do not introduce mere surface features, but rather require using different knowledge resources in order to see “the same thing.” Transfer is thus not simply a matter of possessing and employing a tool, but rather of broadening ones’ understanding of a concept to include the new context in which it is employed.

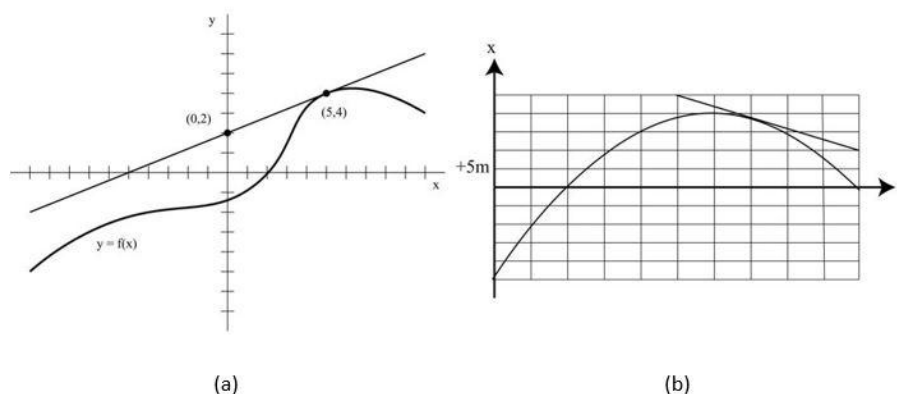

Figure 1. Graphs for interview tasks. Figure 1a is adapted from Asiala et al (1997). The third graph is not shown but is described further in Taylor & Loverude (2019).

Methods and analysis

We designed a research protocol to probe student use of functions in physics. The protocol focused on three graphs (the first two are shown in Fig. 1). For the first, drawn from Asiala et al. (1997), students were asked questions relating to the function and its derivative based on the graph. The second was a physics kinematics graph (position vs. time) informed by PER results on student difficulties with position and velocity (see Fig. 1b), and is the focus of this paper. The third task (not shown) is described in previous work (Loverude and Taylor 2020) and was influenced by work by Moore and Paoletti (2015) on bidirectional reasoning.

This research took place in the context of a two-semester introductory calculus-based physics sequence at a large public comprehensive university in the western United States. The course is required for physical science and engineering majors, and sections are typically taught very traditionally by a variety of instructors, none affiliated with this research study. The course uses a common introductory physics text and covers a fairly standard list of topics.

We performed semi-structured think-aloud interviews with volunteer students [$N=7$]. Interview volunteers were chosen from among students who had recently completed the first semester course with grades of A or B; several were enrolled in the second-semester course. All students had completed relevant instruction on kinematics as well as at least two semesters of calculus. Students came from academic majors including physics, engineering, and mathematics. Data were collected through audio and video recordings and transcribed for analysis.

This analysis focuses on the task in which students were asked to determine a function $v(t)$ for the motion of object 2. To answer, students were expected to assume constant acceleration (all did) and determine multiple values of velocity (typically at $t=0$ and at the local maximum $t=6$) by determining slopes of relevant tangent lines. Students could generate a graph of velocity versus time and/or do a symbolic calculation.

Results

Producing a function $v(t)$ proved to be challenging for students. Five of seven ultimately constructed an expression with the appropriate functional form, but most required some guiding by interviewers. Many students had difficulty in interpreting the velocity at $t=0$, dividing x by $t=0$, or stating that the initial velocity must be zero or negative.

The majority of students initially attributed the motion to a two-dimensional trajectory or projectile motion. Some students assumed that the acceleration was thus the free-fall value of $g=9.8$ m/s^2 . After this confusion became apparent, students were coached by the interviewer to recognize the motion as one-dimensional when needed.

As we are focusing on the experiences of students with transfer phenomena, we briefly describe two categories of responses that were coded as reflecting transfer issues, in which students articulated tension between practices in mathematics and physics.

A. More than just notation; y vs. x and x vs. t

Many students expressed difficulty in reasoning with $x(t)$ as opposed to $y(x)$ as is more typical in calculus courses. Many students mislabeled functions at various times and/or articulated a confusion between graphs of y vs. x and x vs. t . We might expect that students, like experts, can fluidly change between notations, but many students associated the graph with projectile motion as they articulated confusion about the axis labels and functional notation.

For this section we focus on the responses of a single student, Student 6. When first examining the graph, she stated that it was “2-dimensional motion ‘cuz it’s on the x and y axis.” While incorrect, we interpret this as an (unproductive) example of transfer; the y vs. x graph of projectile motion has the same shape and the student recognized a parabola, writing $f(x) = x^2$, then $f(x) = y$.

After being directed to the axis labels and recognizing the motion as one-dimensional, the student expressed confusion between x of t and f of x . While determining the slope at $t=0$, she wrote $f(t) = x$ and $f'(t) = 3$, then scribbled both out in frustration.

S6: So slope, I don’t know if this has, let’s call this $f(x)$. So $f'(0)$ would be 3, right? If x is t , I don’t know. If x is t . I don’t know what I’m doing.

...

S6: Well, I was originally going to try to make this look mathematical with a whole function and everything, but if I had $f(x)$ I guess I could do that. No that doesn’t make sense, $f(t)$ is equal to x , I guess. Right, cuz at some time you get your value, so it’s really $f'(t)$.

We interpret her statement ‘to make this look mathematical’ as illustrating the tension between physics practice, primarily quantity-based, and those of function-based calculus instruction. This student, a math major, further articulated her confusion between different graphs:

S6: In the math books, it’s always in terms of x and y , so it’s either gonna be x or x' or x'' ... and then in physics, there’s like, well, no, this isn’t f of x' , it’s velocity ... No, it’s f of x' ! So, I guess it’s the same thing, it’s just written differently.

This student was ultimately dissatisfied with her response, and continued to express frustration reconciling physics and mathematics conventions, as seen below. Nearly all of the students made comments about the notation and moving fluidly between the two sets of notation was not common.

B. Mathematics vs physics

Several of the students articulated a perceived difference between the mathematics used in physics and that in calculus. While experts might perceive the math in kinematics to be very closely aligned between the two disciplines, some students’ perceptions differ.

One student constructed an equation for velocity as a function of time in a formal, mathematical way, using ordered pairs and slope-intercept form. When prompted to recall the kinematics equations, he was surprised to see that he had unknowingly “re-derived” one of them.

I: You did not [use]...kinematics equations... Would that have been relevant here?

S3: ...let’s say this is velocity initial. Velocity final... Acceleration..., and time... this is v final equals acceleration times time plus velocity initial... So it’s the same equation?! I didn’t even relate that.

A second student determined an expression $y = ax^2 + bx$ for the parabola and was attempting to take its derivative. After shifting to a function of time, he noted the t^2 term and noted the connection to a physics equation with $\frac{1}{2} at^2$. He was unsure due to inconsistent notation, and expressed doubt:

S2: I feel like it's not right because it's not one of the fundamental equations we use in physics class. Where this is one of them and then v_f equals v_{initial} plus a t ... Oh wait that's the same. I don't know. I'm sorry.

Another student, frustrated after having written $v(t) = -3/5x + 10$, summarized her experience:

S1: I have math and physics on different days, so I forget about math when I go to physics, I forget about physics when I go to math.

The math major quoted above went so far as to say that the kinematics equations were not mathematics the way she thought about mathematics:

S6: Not to, like, belittle this equation, but ... there's not really math to it. ... I guess that's dumb if I say I don't think of this as a math equation, cuz it is. But I just thought of it as, just plug in your numbers, get an answer, go home. That's it.

Discussion

Though this is a small sample and preliminary analysis, student responses reflect a recurrent tension between the calculus sequence and the mathematics encountered in physics. Physics instructors may well assume that transfer is trivial in the case of kinematics, but student experiences suggest that it is indeed necessary to develop additional knowledge to be able to see the mathematics and physics as 'the same thing.' Several students had realizations of this nature during the interviews. While this was encouraging, we might prefer that such connections would have occurred while they were taking the course.

Despite the perception of physics as closely associated with math, students expressed differences between physics math and calculus. In the most extreme version, a math major stated that the calculations she did in physics didn't seem like math to her. We note that function notation is used sparingly in most physics textbooks and courses. In the course text used by these students, function notation is used in the chapter on one-dimensional kinematics, but generally not thereafter. In other words, these tensions arise despite this material being the most closely aligned between physics and math practice. As the course continues, there are typically more symbols and parameters than students typically encounter in calculus courses.

We suggest that it would be valuable for physics instructors to learn more of the research on student learning in mathematics and to reflect upon the differing conventions students encounter as they navigate these courses. Calculus instructors might also find it valuable to be acquainted with the practices of other disciplines and attend to interpretation. There is a need for additional explicit attention in both disciplines to the experiences of students as they navigate this material.

Acknowledgments

This work is part of a collaboration with John Thompson (University of Maine) and Warren Christensen (North Dakota State University). This work is supported by the NSF through grant PHY-1912660; opinions, findings, and conclusions are those of the author and do not necessarily reflect the views of the NSF.

References

- Asiala, M., Cottrill, J., Dubinsky, E. & Schwingendorf, K. E. (1997), *The Development of Students' Graphical Understanding of the Derivative* J Math Beh 16, 4 (1997) 399-431
- Beichner, R. (1994). *Testing student interpretation of kinematics graphs*, *American Journal of Physics* 62 (1994) 750-762.
- Bing, T.J., & Redish, E. F. (2007). The Cognitive Blending of Mathematics and Physics Knowledge, in *2007 Phys. Educ. Res. Conf. Proc.*, (AIP Conference Proceedings 951, 2007) 26-29.
- Carlson, M. (1998). A cross-sectional investigation of the development of the function concept. In A. H. Schoenfeld, J. Kaput, & E. Dubinsky (Eds.), *CBMS Issues in Mathematics Education* (Vol. 7, pp. 114–162). <https://doi.org/10.1090/cbmath/007/04>
- Cui, L., Rebello, N. S., Fletcher, P. R., & Bennett, A. G. (2006, April). Transfer of learning from college calculus to physics courses. In *Proceedings of the annual meeting of the National Association for Research in Science Teaching*.
- Fauconnier, G. & Turner, M. (2002). *The Way We Think: Conceptual Blending and the Mind's Hidden Complexities*, (Perseus Books Group, New York, 2002) Vol. 1.
- Halliday, D., Resnick, R., & Walker, J. (2018). *Fundamentals of physics*. John Wiley & Sons.
- Lobato, J. (2012). The Actor-Oriented Transfer Perspective and Its Contributions to Educational Research and Practice. *Educational Psychologist* 47(3), 232–247.
- Loverude, M.E., and Taylor, H. (2020), Student Responses to an Unfamiliar Graphical Representation of Motion, *RUME Conference Proceedings 2020*.
- McDermott, L.C., Rosenquist, M. and van Zee, E. (1987). Student difficulties in connecting graphs and physics: Examples from kinematics, *American Journal of Physics* 55 (1987), 503–513.
- Moore, K. C., and Paoletti, T. (2015). in *Proc XVIII Ann Conf on RUME, 2015*, (West Virginia University, Pittsburgh, 2015), 774–781.
- Oehrtman, M., Carlson, M., & Thompson, P. W. (2008). Foundational reasoning abilities that promote coherence in students' understandings of function. In M. Carlson & C. Rasmussen (Eds.), *Making the connection: Research and practice in undergraduate mathematics* (pp. 27–42). Washington, D.C.: Mathematical Association of America.
- Park, J. (2015). Is the derivative a function? If so, how do we teach it? *Educ Stud Math* (2015) 233–250.
- Wagner, J.F. (2006). “Transfer in pieces,” *Cognition and Instruction* 24, 1–71.

Integration and differentials in a textbook for engineering science and building materials

Hans Kristian Nilsen

University of Agder, Norway; hans.k.nilsen@uia.no

Background and research question

The relevance of mathematics in the education of different professions is an ongoing debate and the engineering education is no exception. In a recent study, we investigated first-year engineering students in a university in Norway, and their conceptions of integration (Nilsen & Knutsen, 2023). In the wake of the interviews with the students, a curiosity arose, related to the relevance of differentials and integration later in their education, specifically in more technical engineering courses. Rooted in the framework of anthropological theory of didactics (ATD), the following research question guides this paper: *What characterizes the praxeology of integrals and differentials in a textbook on building materials?* The intention with this research question is two-folded: 1) To investigate how integrals and differentials are accounted for in a mathematical sense and 2) To investigate the role these play in the actual subject matter content at hand. Both these aspects aim to illuminate how calculus is presented in engineering courses, versus the preceding calculus course. The goal is that an identification of possible differences, and an awareness of possible obstacles these might lead to when it comes to students learning, could be a valuable contribution to the body of research in mathematics education aimed at universities and university colleges.

Theoretical framework

This study, on calculus in textbooks for engineering courses, is highly inspired by González-Martín and Hernandes Gomes (2018), where engineering textbooks used in Brazil were analyzed. An anthropological theory of didactics (ATD) approach will be adapted, as the different *praxeologies* (Bosch & Gascón, 2014) provide a suitable vocabulary to describe the nuances in the different contextualizations of calculus. A praxeology or mathematical organization (MO) is the contextual basis for the mathematical content, where a type of task (T) and certain techniques (τ) constitute the *praxis*. The *logos* consists of a technology (θ), which justify the different techniques needed and a theory (Θ), which anchor the technology in an underlying historical developed set of mathematical concepts. For this paper, I will point to two different MO 's relevant for integrals.

I will refer to MO_1 as the “rigorous limit-based approach” (Nilsen & Knudsen, 2023), an approach which is used especially in the introduction to integrals in the engineering students’ calculus textbook. The core idea is that Riemann integrals are limits of upper- and lower bound Riemann sums, and that the Riemann-integral are “sandwiched” between these bounds. Besides the calculation of different integrals, the praxis involved in this approach are often linked to evaluating converging sums, and the logos rests on the limit concept.

MO_2 could be described as “the infinitesimal approach” and is not directly accounted for in the students’ calculus textbook but is implicitly present in the parts that deals with applications. The logos of MO_2 is rooted in Newton and Leibniz, where integrals are regarded as sum of bars with infinite

small widths. Later this approach was formalized through hyperreal numbers. The praxis of MO_2 typically consists of tasks where differentials occur as slices or sections of actual physical magnitudes, which are to be “summed up” through integration techniques.

Methods

As a follow-up study of first-year engineering students’ interpretations of integrals, it was of interest to identify a “technical course” in their educational pathway, that contained integrals, and that came as close as possible to their calculus course in the first semester. This rests on the assumption that students’ first meeting with calculus in another subject would be of most significance for their possibility to link the content to the calculus course. In this context, “technical course”, refers to an engineering course where calculus concepts are not explicitly stated among the learning outcome goals in the official course plan, but still play a role in the course content. The actual course relevant for this paper is “science of engineering and building materials” (translated from the Norwegian course-name “Materiallære”) and occurs in the second year of three engineering study programs: mechatronic-, civil and structural-, and renewable energy engineering. The first two examples in the textbook for this course (Burstöm, 2021) where integrals explicitly appear, are treated. The first example concerns materials’ capillary transport, and the second example deals with materials’ deformation properties. Since the textbook analyzed does not contain any kind of activities or tasks for the students to solve, it is important to add that the analysis only focuses on examples that the textbook uses to mediate content that involves integrals. Hence “type of tasks” (as part of *praxis*), is interpreted as *possible* tasks, based on the examples presented. The focus of the analysis is therefore on how the mathematical notations and properties of the involved integrals are accounted for, and the role they play in the explanations of the physical phenomena at hand.

Analysis

The first example is from the chapter on “humidity” and a section with the title “humidity transport in liquid phase – capillary transport”.

When a circular tube takes in water horizontally, the pore water pressure (under-pressure) by the meniscus is constant (figure 5.18). The under-pressure equals the capillary under-pressure (suction), s , given by the equation 5.9. If the distance between the meniscus and the surface area of the material is x_1 [m] the water velocity could be written:

$$v = \frac{dx_1}{dt} = \frac{r^2}{8\eta} \cdot \frac{s}{x_1} = \frac{r\sigma\cos\theta}{4\eta x_1} \quad (5.14)$$

[...]. The time, t [s], needed for the meniscus to reach the depth x_1 could be found by equation 5:15:

$$t = \int \frac{4\eta x_1}{r\sigma\cos\theta} \cdot dx_1 = \frac{2\eta}{r\sigma\cos\theta} \cdot x_1^2 \quad (5.15)$$

which also could be written

$$x_1 = \sqrt{\frac{r\sigma\cos\theta}{2\eta} \cdot t} \quad (5.16)$$

Hence, the intrusion depth (and the absorbed amount of water) are proportional both to the square root of time and the square root of the radius.

Example 1: Capillary transport (Burstöm, 2021, pp. 94-95, translated from Swedish)

From the example, one observes few attempts of linking the subject matter content to terminology known from the calculus praxeology. The calculus involved is exclusively displayed through mathematical notations, and meaning making related to these is apparently left to the reader. Differentials and the associated notations are presented without using words like “differential”, “limit”, “sum” or “integral”, but are instead indirectly linked to physical magnitudes like “time”, “water velocity” and “intrusion depth”. The square root expressions being “proportional” is the only mathematical property that is explicitly described in the text. Since it is left for the readers to link the mathematical praxeology to the subject matter content, the MO is hidden, and can only be interpreted implicitly. The differential in the integral at hand is linked to a distance (intrusion depth), and the integrand is linked to fluid mechanical laws playing out in the circular “slice” of a tube at any given point along the intrusion depth. This interpretation somewhat fits the rationale of MO_2 .

The second example is from the chapter called “strength”, under the section “normal stress, deformation and fractures” and concerns the notion “line of work” (translated from Swedish “arbetslinje”).

The tension perpendicular to a surface is called “normal stress” and is denoted as σ (sigma). In this case, $\sigma = \frac{F}{A}$. Influenced by the tension σ , the rod prolongs by a piece ΔL . The relation between the prolongation ΔL and the original length L is called *strain* and are denoted by ε (epsilon). $\varepsilon = \frac{\Delta L}{L}$. [...]. The term “line of work” is motivated from the following: Assume that the force F in figure 6.1 [figure omitted in this excerpt] gains a contribution dF , leading to a length alternation contribution $d\Delta L$. The required work ($= dW$) then becomes: $dW = \left(F + \frac{dF}{2}\right) \cdot (d\Delta L) \approx F \cdot (d\Delta L)$. When $F = A \cdot \sigma$ and $d\Delta L = L \cdot d\varepsilon$, one gets $dW = A \cdot L \cdot \sigma \cdot d\varepsilon$. The total amount of work for the prolongation, ε_1 , of the rod becomes $W = \int dW = A \cdot L \int_0^{\varepsilon_1} \sigma d\varepsilon$, that is the volume of the rod multiplied by the surface between the line of work and the ε -axle to where $\varepsilon = \varepsilon_1$. From the line of work one can read how much work a material can absorb by a given deformation or before it fractures.

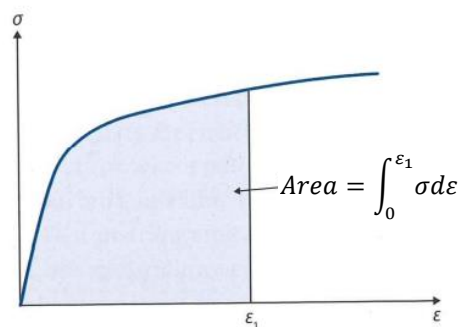

Example 2: Line of work (Burstöm, 2021, pp. 126-128, translated from Swedish)

In contrast to the first example, the differentials involved are now explicitly accounted for, even though exclusively through physical interpretations. Terminology associated by the logos of calculus (i.e. limits, differentials, sums, integrals) is avoided also in this example, and it is left for the reader to draw such possible parallels. Further, mathematical notations are here used in a different way than in the case of MO_1 , where the Δ in Riemann sums represents the interval Δx_i that approaches dx , as the length of all subintervals approaches zero. Not only are Δ and d used differently, but they are combined in an unusual way, through $d\Delta L$. A sum-based interpretation in line with MO_2 characterizes

the example as all the differentials are equated with actual physical magnitudes without any emphasis on limits. The word “contribution” in different variants enforces this interpretation.

Discussions and conclusions

These two examples might represent challenges related to connecting the content to associated praxeologies in calculus, when students encounter integrals in other subjects than mathematics. The logos (technology and theory) of calculus is at best rudimentary traced, in the examples provided. In the first example the differentials and integrals involved are not accounted for in the text, neither through explanations nor proper definitions. Hence, what the integral actually *does* is left to the reader to interpret. In the second example, the involved differentials are associated with physical magnitudes, interpreted respectively as force- and length “contributions”. The integrals tacitly illustrate a sum, in line with MO_2 . The differences identified, between how integrals are presented in the calculus course and this technical course, might constitute a challenge related to both the technology and theory of the calculus praxeology, especially related to MO_1 , and how integrals normally are introduced. The need for engineering students to conceptualize integrals as sums of actual physical magnitudes has been pointed out also in other studies (e.g. Jones, 2015) and hence the learning outcome of MO_1 might be questioned, for this group of students. Further, it could be of importance for university teachers to be aware of the differences between how notations and expressions are interpreted in calculus courses, compared to technical engineering courses, where calculus is being applied. This probably applies both to the teachers of technical courses and to the calculus teachers, as both the examples demonstrate the need for prerequisite knowledge which includes flexibility in notations and a highly developed MO_2 .

References

- Bosch, M., & Gascón, J. (2014). An introduction to the anthropological theory of the didactic. In A. Bikner-Ahsbahs & S. Prediger (Eds.), *Networking of theories as a research practice in mathematics education* (pp. 67–83). Springer.
- Burstöm, P. G. (2021). *Byggnadsmaterial. Tilverkning, egenskaper och användning* [Building materials. Production, properties, and application]. Studentlitteratur.
- González-Martín, A. S., & Hernandez-Gomes, G. (2018). The use of integrals in mechanics of materials textbooks for engineering students: The case of the first moment of an area. In N.M. Hogstad, V. Durand-Guerrier, S. Goodchild, & R. Hochmuth (Eds.), *Proceedings of the second conference of the international network for didactic research in university mathematics* (pp. 115–124). University of Agder and INDRUM.
- Jones, S. R. (2015). Areas, anti-derivatives, and adding up pieces: Definite integrals in pure mathematics and applied science contexts. *Journal of Mathematical Behavior*, 38, 9–28.
- Nilsen, H. K. & Knudsen, K. H. (in press). First-year engineering students’ interpretations of differentials and definite integrals. *International Journal of Research in Undergraduate Mathematics Education*.

Influence of learning physics on reasoning about RoC and accumulation

Lia Noah-Sella¹, Anatoli Kouropatov², Dafna Elias¹, Tommy Dreyfus¹

¹Tel-Aviv University, Israel; lianoahsella@gmail.com

²Levinsky College, Israel; anatoliko@gmail.com

Introduction and theoretical background

The use of math in physics differs from the use of math in math classes. In particular, physicists interpret equations differently from mathematicians since they imbue symbols with physical meaning (Redish & Kuo, 2015). In this paper we present findings indicating that physics students in Israeli high schools also engage differently with graphs. Many are influenced by their experiences using graphs in physics when engaging in covariational reasoning and when relating to rate of change (RoC) and accumulation. They view RoC as a physics concept. They view their reasoning with graphs in physics as thoughtful and meaningful, and their activity in math as procedural and technical.

Methodology

We interviewed over 50 Israeli 11th and 12th grade students studying advanced track math on various calculus items centered around either RoC or accumulation. The items varied in context, either intra-mathematical (function values, area) or extra-mathematical (motion, filling a pool, temperature varying during a day). Each item presented a function verbally, algebraically, and/or graphically, and a question concerning RoC or accumulation (e.g., what is the meaning of the statement ‘the RoC of $f(x)$ at $x=3$ is 0.47’?). Students were presented with 5-8 answers given by hypothetical people, and showcasing different possible ways of thinking (e.g., ‘for me, the meaning is that if we graph the function, the slope of the tangent at $x=3$ will be 0.47’). The students were asked to reflect on these answers. Each student was interviewed separately on one or two items. Student were told that they would be interviewed concerning ways they think about mathematical notions. They were also told that the interviewer was not interested in right or wrong answers, but in their ways of thinking, and all answers were essentially correct. Of the students interviewed, 21 also studied physics. The interviewer did not mention physics at any stage unless the student brought up their physics studies.

The interviews were audio-recorded and transcribed in the framework of a larger project. While examining the transcriptions we noticed many students referred to their physics studies and decided to investigate this. We analyzed the transcripts, searching for utterances that included the terms ‘physics’, ‘math’, ‘calculus’, etc. Then we coded all relevant utterances using grounded theory, searching for patterns and common themes between interviewees. A partial list of themes follows.

Findings and discussion

In the interviews, though the problems were presented as math problems, and the students knew the research centered around the way they think about mathematical concepts, 16 students of the 21 who study physics related to physics in their reasoning, using phrases such as: “really, all I am saying right now is just from physics”, “can I explain, physics? Like, the way I see it”, “all these things are more related to physics than to math for me”.

Math is technical while physics requires thought

The theme that stood out to us first was the claim that math involves rote procedure whereas physics involves thinking. The perception of math as rote technique was not unique to physics students and appeared also among students who do not study physics. The following is a partial list of quotes from different interviews; physics students are marked (p), and students who did not study physics (np):

- Bar (p): Math is usually very analytical and technical thinking, and working according to steps, but physics is really more thinking about what you're doing
- Lynn (np): I think I learned more [in the interview], not even learned, like more used my reasoning rather than a formula [...], like I really enjoyed using my brain. Because I, it doesn't happen a lot in everyday math learning.
- Sam (np): This isn't math. Right, it isn't standard, it isn't computational.

While six students related math to rote procedures and physics to more in depth thought, only two students contended that physics is technical.

- Ray (p): We don't really study integrals in physics. Like... they just show us formulas and then tell us 'use them'. We don't really study how to get to them so, we didn't encounter integrals at all in physics.

Only one student contended that math isn't technical:

- Yanai (p): [My teacher] emphasizes explaining everything behind the math. Not just remembering this formula or that, but also understanding where it comes from, and... it really, it really got me to appreciate math, because I'm like oh, wow! There are four hundred different explanations to everything, and it all works together.

Graphs in physics are more meaningful to students than in calculus

Another theme that arises in the interviews is that the participants refer to different practices when solving problems in physics and in math. The main difference concerns working with graphs in physics. Of the 16 physics students who related to physics in their explanations, 12 referred to graphs in physics. Some of these students contrasted working with graphs and the rote nature of working with algebraic expressions in math:

- Tal (p): But in physics it was just like more understanding, it was deeper. You need to understand it for graphs and stuff... in math it was just equations.
- Bar (p): And in physics I really, every time I have to think about what I need to do, and we have a lot of work with graphs. There are a lot of questions about graphs – is the velocity squared? is the velocity with constant acceleration? And we don't have that in math.

This finding is intriguing since in the Israeli math curriculum, textbooks, and final exams, the majority of calculus questions involve graphs – constructing a graph from an algebraic formula, graphically finding graphs of derivatives and antiderivatives and the connections between them, etc. Thus, we initially found it surprising that physics students consider working with graphs as a practice used in physics and not so much in math. Closer examination of students' statements reveals what they mean by 'working with graphs' in further detail. Due to space limitations, we present only the statements made by Tal; other students made similar, less detailed comments.

Tal (p): A lot of times [in physics] there is like a reference to the proportionality between variables. Like in formulas – directly proportional, inversely proportional – it's really in my head all the time, and also the way you see it in the graph. [...] And then how you see it, it just helps to understand things [...] but I'm like talking about the thing of, how you see the function in the graph, and like the meaning of, for example in tenth grade we learned kinematics and there was the connection between velocity-acceleration-distance. So, everything is like a derivative of one another.

Tal (p): [In physics] graphs that was like distance to time and you had to calculate the velocity, and it wasn't a linear graph it was like say a parabola.

Tal's account of working with graphs in physics reveals two main aspects. First, students can use graphs to reflect on covariation of quantities as is evident from her statement on proportionality. Covariational reasoning is not strictly necessary in Israeli final exams in math and does not appear in current textbooks. Ergo, we may assume that in many classrooms it is not cultivated. Second, graphs in physics represent real-world entities such as distance, velocity, and acceleration, whereas in the math curriculum, there is little use of extra-mathematical context in calculus. Moreover, in the latter quote Tal describes a situation where a given graph is made use of to find the size of such a quantity.

This finding is strengthened by some statements made by students who do not learn physics:

Lynn (np): When we just started learning graphs, a really long time ago, they taught us that it jumps like steps, so the step of the height will be smaller with time than the step...the step of the height will like decrease, and the step of the time will remain the same, so slowly the graph is like advancing at a slower pace upwards than downwards.

When Lynn uses covariational reasoning she needs to invoke experiences from very long ago. She does not relate to her current calculus studies, but rather to learning linear functions in middle school.

Rita (np): Basically, in questions in tests and stuff, obviously I'll look at the function first and not at the graph. But if I have a graph, it helps me understand.

For Rita, even though graphs are useful for understanding, considering the graph is secondary, not suitable for tests. This suggests that it is deemed less correct or less mathematical.

RoC is related to physics and not to calculus

A third theme present in the interviews is that the students view RoC as a concept related to physics and not so much to calculus. This agrees with the previously discussed finding that engagement with graphs in physics is related to covariational reasoning. This was particularly evident when students were asked if they are familiar with the term RoC from school:

Ira (p): Yes, in physics, we do a lot of graphs.

May (p): In physics mostly, because we talked about graphs in physics, and then we talked about RoC.

Yanai (p): So, I, because I learned functions in math before I learned it in physics then, the RoC of the distance was always just a word to me, a phrase that says slope. [chuckles]

Interviewer: So, did you hear the term RoC in math as well?

Yanai (p): Not so much, no. I heard it when I got into physics. About the first thing we learned was velocity-time and position-time graphs. And there you talk about RoC constantly, which is just the slope of the graph.

While the concept of RoC appears in the seventh and eighth grade math curriculum in Israel, particularly in relation to linear functions, up until recently it has not been a part of the high school curriculum. Furthermore, high school math textbooks and exams do not incorporate extra-mathematical contexts in calculus. Thus, this finding is not surprising.

Next year Israeli high schools will implement a new math curriculum that includes concepts of RoC in calculus. The introduction of the new curriculum could have a significant effect on students' conceptions of RoC and calculus. On the other hand, the concept of accumulation and the accumulation function have been gradually introduced into exams in recent years. While more students accepted accumulation to be a mathematical concept, many still did not identify with this way of thinking and some still considered it to be less 'mathematical'.

Dale (np): [On accumulation] I marked it as [...] not so close to what I thought, because I thought about the integral, about the formula, about math, formulas, plugging in and stuff like that, and they were looking at it more differently, like there is somehow a line maybe, that shows how the water progressed from there to here.

Shaked (p): First of all, [accumulation] relates a little less to the world of math [than area], that bothers me a little [...], [accumulation] seems like a word that describes something less accurate, a little more generalized I would say. So, umm, if he were to say volume, like that is also similar, but [...] sounds more accurate to me, more specific. The word accumulation seems more generalizing.

Concluding remarks

In conclusion, the vast majority of physics students we interviewed related to physics when asked to reason in calculus. Thus, it appears that Israeli physics students are highly influenced by their experiences in physics when engaging in calculus problems that involve covariational thinking, RoC and accumulation. They relate the practices they use to physics, rather than to math.

The three themes presented are strongly connected. Students relate RoC and covariational reasoning to working with graphs in physics and relate calculus to thoughtless symbolic procedures.

Thus, we surmise that engagement with graphs that represent quantities in math lessons could foster development of covariational reasoning, as well as concepts of RoC and accumulation among math students, while making the experience of math learning more 'deep' and less 'technical'.

Acknowledgment

This research has been supported by the Israel Science Foundation under grant 1743/19.

References

Redish, E. F., & Kuo, E. (2015). Language of Physics, Language of Math: Disciplinary Culture and Dynamic Epistemology. *Science & Education*, 24(5–6), 561–590. <https://doi.org/10.1007/s11191-015-9749-7>

The procedural-conceptual dichotomy is not invariant under transposition to applied fields

Reinhard Oldenburg¹

¹Augsburg University, Germany; reinhard.oldenburg@math.uni-augsburg.de

Introduction

The dichotomy between procedural and conceptual knowledge has been studied extensively in mathematics education in general and in higher education (Rittle-Johnson & Schneider, 1999; Engelbrecht, Bergsten, & Kågesten, 2012). Often it is conjectured that more conceptual understanding is needed while in actual teaching procedural techniques dominate (although already Rittle-Johnson and Schneider (2015) emphasized that they are intertwined). The importance of conceptual knowledge goes without doubt, although its components and the ways to measure it are less elaborate than for procedural knowledge. Among the research strands that investigate conceptual knowledge in calculus is the work on basic mental models (Greefrath et al., 2021). This identifies conceptual dimensions, but they are all rooted in the praxis of typical German high school teaching.

If strengthening conceptual knowledge is to be effective, it must be conceptualized in a way that respects the structure of the field that mathematics will finally be applied to. This paper investigates the techniques of multivariate integration by parts together in detail and some additional examples.

Research hypothesis: When a body of mathematical knowledge gets transposed from pure mathematics to an application field, the classification as procedural or conceptual may change.

Methodology and Theory

The first underlying methodological framework of this research is the anthropological theory of the didactic (ATD; Chevallard, 2019). It models knowledge by praxeologies $\mathcal{p} = [T / \tau / \theta / \Theta]$ where T denotes a task or a type of tasks, τ is a technique to solve it, θ is a technology that explains τ , and finally Θ is a theory that justifies θ . This is applied to integration by parts.

Integration by parts underlies the mathematical task (taken from Höllig and Hörner (2021, p. 251)) $T_1 =$ "Calculate $\iint_{\mathbb{R}^2} (x + \cos(y)) \cdot \partial_x \exp(-\sqrt{x^2 + y^2}) dx dy$ ". The transposition of partial integration to physics is exemplified by $T_2 =$ "Calculate the energy density in electrostatics". Both tasks use (among other things) the technique to rewrite an integral according to the multivariate rule of integration by parts. This part of θ is essentially the theorem that for scalar functions $u, v: \mathbb{R}^n \supset \Omega \rightarrow \mathbb{R}$ with adequate properties of integrability and differentiability one has $\int_{\Omega} u \cdot \partial_{x_j} v d\Omega = \int_{\partial\Omega} u \cdot v \cdot (e_j \cdot n) d\Gamma - \int_{\Omega} \partial_{x_j} u \cdot v d\Omega$, where e_j is the j -th unit vector and n is a normal vector on the surface $\partial\Omega$ of the region Ω . This theorem and thus θ rests on the theory of multivariate integration Θ as foundational theory. We will investigate the praxeologies $\mathcal{p}_i = [T_i / \tau_i / \theta / \Theta]$, $i \in \{1, 2\}$.

The second underlying conceptual framework is the distinction between conceptual and procedural knowledge (Engelbrecht, Bergsten, & Kågesten, 2012; Rittle-Johnson & Schneider, 2015). Rittle-Johnson and Schneider discuss several possible definitions but conclude simply "there is general consensus that conceptual knowledge should be defined as knowledge of concepts" and that

“procedural knowledge is the ability to execute action sequences (i.e., procedures) to solve problems”. Rittle-Johnson & Schneider (2015) have stated that “conceptual and procedural knowledge cannot always be separated”. This is not by accident similar to the blurry distinction line between syntactical and semantical test items (Oldenburg, Hodgen & Küchemann, 2013). Girard (1989, chapter 1) links this to the relevance of “sense” in the sense of Frege and it is mainly the sense that is affected by transpositions.

The mathematical praxeology \mathcal{p}_1

Solving task T_1 in mathematics will typically be taught and exercised in the following manner: One uses the above given theorem on partial integration for a circle of some large radius R and estimates that the surface integral (in this case a line integral) will approach 0 as $R \rightarrow \infty$ because the integrand decreases fast enough. Thus, one has in the limit of integrating over all of \mathbb{R}^2 that

$$\iint_{\mathbb{R}^2} (x + \cos(y)) \cdot \partial_x \exp(-\sqrt{x^2 + y^2}) dx dy =$$

$$0 - \iint_{\mathbb{R}^2} \partial_x (x + \cos(y)) \cdot \exp(-\sqrt{x^2 + y^2}) dx dy = - \iint_{\mathbb{R}^2} \exp(-\sqrt{x^2 + y^2}) dx dy = -2\pi$$

(where the last integral is worked out using radial coordinates). Thus, to solve T_1 one applies a technique τ_1 that relies on θ and consists of approximating the integral over the unbounded \mathbb{R}^2 by integrals over disks and taking the limit of the radius. I argue that the praxis part [T_1 / τ_1] is procedural, because one is interested in the result (a number) and this result can be obtained by procedural, even algorithmic working style. This can be demonstrated by the fact that the whole calculation process can be carried out by computer algebra systems (although one may need to initiate the coordinate transformation by hand), it is guided by the structure of the expressions alone. No further conceptual considerations are necessary to arrive at the answer required by the task.

The physical praxeology \mathcal{p}_2

Task T_2 must be described in a bit more detail. A distribution of charge in space described by a charge density function $\rho: \mathbb{R}^3 \rightarrow \mathbb{R}$ will store some energy due to the forces between charged particles (Jackson, 1975, p. 46). The charge in space defines a potential $\Phi: \mathbb{R}^3 \rightarrow \mathbb{R}$ that gives rise to the electric field strength $E = -\nabla\Phi$. Moreover, one knows that the Poisson equation $\nabla^2\Phi(x) = -4\pi\rho(x)$ holds. The potential and the charge combine to give the energy of the charge distribution according to $W = \frac{1}{2} \int \rho(x)\Phi(x)d^3x$. Plugging in the Poisson equation one gets $W = \frac{-1}{8\pi} \int (\nabla^2\Phi(x))\Phi(x)d^3x$. The physical interpretation of this is that the total energy is summed up from the charges (i.e. $\nabla^2\Phi(x)$) weighted by their potential $\Phi(x)$. Now, perform partial integration to get $W = \frac{1}{8\pi} \int \nabla\Phi(x) \cdot \nabla\Phi(x)d^3x = \frac{1}{8\pi} \int |E|^2 d^3x$ (the border integral is, just as in T_1 , zero). Thus, the energy density is now expressed in terms of the electric field. This insight is not just the result of applying a procedure. Instead, it requires conceptual considerations and interpretations. This is true even if the technology τ_2 applied here contains much of the same calculations as τ_1 , but it extends τ_1 by the physical interpretation of the transformations applied. Within τ_2 a transformation is not just a syntactical manipulation to get closer to the desired answer (that can be understood without), but it is a transformation of the meaning of the expression. Let’s explain the difference for the sub-technology of seeing that the border integral does not contribute. In τ_1 this is a standard limit argument that relates

the length of the curve and the maximum of the absolute value of the integrand to infer from the formula that for $R \rightarrow \infty$ the integral will vanish. The argument from τ_2 that allows to omit the border integral is different. No concrete function is given and thus the vanishing cannot be inferred. Rather, it follows from general physical principles that fields tend quickly to infinity. Furthermore, the knowledge that integration by parts should be applied comes in τ_1 from the syntactical properties of the expression (the first factor is linear in x), while in τ_2 such a syntactical clue is completely missing. Thus, while in p_1 transformational procedures are guided by the structure of the expression which can itself be analyzed procedurally, in p_2 it is understanding of the concepts that guides the process and indicated what final form is sensible (i.e. has sense). Summarizing, the same integration by parts turned out to be a syntactical tool to solve T_1 , but a conceptual tool to switch the way in which the physical reality is described in T_2 . The passage from p_1 to p_2 is indeed an example of a didactical transformation, not just an application mathematics, because the arguments and strategies differ. For example, the fact that the border integral vanishes is justified by different arguments.

Further examples

Such examples of conceptual use of partial integration (rather than just procedural use to calculate some results) are not rare and not limited to electrodynamic: proving that Coulomb's law and Maxwell's first equation are equivalent (Jackson, 1975, p. 33), derivation of the Klein-Gordon equation, derivation of Euler-Lagrange equations etc. The last example brings out the conceptual nature of partial integration very clearly because it allows to trade in the change of a variation to the variation itself. Moreover, classifying integration by parts as procedural knowledge gives no adequate description of the way physicists calculate with the derivative of the Dirac delta distribution: To evaluate an integral like $\int_a^b f(x) \cdot \delta'(x) \cdot dx$ with $a < 0 < b$ physicists will apply integration by parts: $\int_a^b f(x) \cdot \delta'(x) \cdot dx = f(b)\delta(b) - f(a)\delta(a) - \int_a^b f'(x) \cdot \delta(x) \cdot dx = -f'(0)$. This is conceptual because it extends the notion of derivative to a new kind of object.

What has been established by now is that what may appear procedural in one praxeology is conceptual in another praxeology. But the situation may even be more drastic, as a look into computer science indicates. Consider the mathematical data structure of a tuple of objects, e.g. the tuple of coordinates of a point in the Euclidean plane. This is a (simple) concept and knowledge about tuples is therefore conceptual. Mathematical knowledge regarding functions defined by an expression or more generally by an algorithm might be classified to be procedural knowledge. However, it is well known (see e.g. <https://web.mit.edu/6.001/6.037/sicp.pdf>, p. 125, for a practical implementation) that the concept of tuple (and hence their complete semantics) can be defined by procedures (hence, data are procedures). However, this insight can be deepened: Knowledge of algorithms and how to carry them out seems to be procedural knowledge. On the other hand, proofs in mathematics are often considered to carry mathematics' conceptual knowledge (e.g., Hanna & Barbeau, 2008). However, the celebrated Curry-Howard correspondence (Girard, 1989; Thompson, 1991) states that proofs (at least of constructive logic) can be turned into strictly typed functional programs and vice versa. This blurs the distinction fully – at least at an abstract level. The lesson is obviously that being conceptual or being procedural is not a property of some piece of knowledge per se but of the concrete praxeology where it is applied.

Conclusion and Outlook

The examples elaborated above have given support to the research hypothesis stated in the introduction. There are many further examples that go beyond the scope of this paper. A first consequence is that when teaching mathematical analysis and calculus for applied sciences the lecturer should investigate the role of the subject played in the application domain. Especially, a teacher educated in pure mathematics may consider some learning objectives to be procedural and based on this classification may decide to give them little weight although in an application area these procedural techniques acquire a conceptual meaning. In the age of computer algebra system students don't need to know integration by parts and by substitution to find antiderivatives. Thus, these topics have been removed from German high school curricula. However, many students will need them as conceptual tools in STEM university courses. In research, one should be aware that the distinction between procedural and conceptual can only be made relative to a certain praxeology, but not absolutely. Hence, interpretation of results of such studies must investigate the concrete praxeology and should be careful when stating conclusions for distinct praxeologies.

References

- Chevallard, Y. (2019). Introducing the Anthropological Theory of the Didactic: An attempt at a principled approach. *Hiroshima Journal of Mathematics Education*, 12, 71–114.
- Engelbrecht, J., Bergsten, C., & Kågesten, O. (2012). Conceptual and Procedural Approaches to Mathematics in the Engineering Curriculum: Student Conceptions and Performance. *Journal of Engineering Education*, 101(1), 138-162.
- Girard, J.-Y. (1989). *Proofs and Types*. Cambridge University Press.
- Greefrath, G., Oldenburg, R., Siller, H.-St., Ulm, V., & Weigand, H.-G. (2021). Basic mental models of integrals: theoretical conception, development of a test instrument, and first results. *ZDM – Mathematics Education*, 53, 649-661.
- Hanna, G., & Barbeau, E. (2008). Proofs as bearers of mathematical knowledge. *ZDM Mathematics Education*, 40:345–353.
- Jackson, J. D. (1975). *Classical Electrodynamics* (2nd ed.). John Wiley & Sons.
- Höllig, K., & Hörner, J. (2021). *Aufgaben und Lösungen zur Höheren Mathematik 2*. Springer.
- Oldenburg, R., Hodgen, J., & Küchemann, D. (2013). Syntactic and semantic items in algebra tests – a conceptual and empirical view. In B. Ubuz, Ç. Haser & M. A. Mariotti (Eds.), *Proceedings of the Eight Congress of the European Society for Research in Mathematics Education*, 500-509, Middle East Technical University.
- Rittle-Johnson, B., & Schneider, M. (2015). Developing conceptual and procedural knowledge of mathematics. In R.C. Kadosh & A. Dowker (Eds.), *The Oxford handbook of numerical cognition*, 1118-1135, Oxford University Press.
- Thompson, S. (1991). *Type Theory and Functional Programming*. Addison–Wesley.

Numerical sensemaking in secondary calculus: Does it make sense?

Alon Pinto and Boaz Katz

Weizmann Institute of Science, Israel;

alon.pinto@weizmann.ac.il; boaz.katz@weizmann.ac.il

Rationale and research aims

In recent years there is a growing recognition of the diverse roles of calculus in STEM education, and of the limited success of calculus education to provide students with effective scaffolding throughout their different academic pathways (Biza et al., 2022). For example, Jones' (2015) findings indicate that many activities and approaches emphasized in the teaching and learning of calculus are generally less relevant for physics students for investigating and making sense of various physics situations. One suggestion for better alignment of calculus education with the different needs of mathematics and physics students is to place greater emphasis on numerical approaches, and specifically on the notion of approximation (Sofronas et al., 2015). Sofronas et al. (2015) suggest that the notion of approximation can be a unifying thread in calculus curricula and provide powerful metaphors that could support the conceptualization of mathematical objects, as well as powerful tools for calculating and applying these objects. The question remains, how can the notion of approximation be used in secondary calculus lessons to promote numerical sensemaking and to connect calculus and physics.

The premise of this study is that the promotion of numerical sensemaking at secondary mathematics (SM) education requires multifaceted knowledge and expertise that does not lie within the confines of any sole stakeholder in mathematics education (Pinto & Cooper, 2022). Among other things, suggesting feasible and meaningful ways to engage students with numerical sensemaking in calculus lessons require subtle understanding of numerical approaches and perspectives, as well as deep familiarity with the SM curriculum and with the professional obligations that underlie SM teaching (Herbst & Chazan, 2022). Accordingly, our research strategy relies on bringing together SM teachers, mathematicians, and physicists to jointly inquire into *why*, *when* and *how* SM students should be engaged in numerical sensemaking (Pinto & Cooper, 2022). This paper builds on a two-year collaboration between the two authors in such a community of inquiry within the M-Cubed project (Pinto & Cooper, 2021). The first author has a PhD in Mathematics and is currently a full-time Mathematics Education researcher. The second author is a full-time Physics professor, who has been teaching physics in 10th-12th grades for the past eight years. In M-Cubed, we have been watching videotaped SM lessons together with another physicists, two mathematicians and eight practicing SM teachers, and discussing mathematical and pedagogical issues that we recognized therein. Often, while discussing concrete instructional situations, we found ourselves also reflecting on differences between how mathematics is taught and experienced at school, and how it is used and perceived in science, and specifically in physics. In this paper, we describe two episodes from M-Cubed where the participants engaged in such reflections in relation to the notion of approximation.

Case 1: Making sense of asymptotes

The trigger for this sensemaking episode emerged when the SM teachers examined how the two mathematicians and two physicists in the group approached various questions in the Israeli high-track

matriculation exam, and then reflected on how these approaches relate to the approaches taught at the secondary level. One calculus problem asked to explore some properties of the function $f(x) = x + \ln(x^2 - 3)$ and sketch the graph of $f(x)$. One teacher, T1, took note of how the physicists in the group immediately observed that $f(x)$ behaves asymptotically like $y=x$. T1 found this very surprising since according to the definition of *asymptotes* in the Israeli SM curriculum (Eisenberg & Drefyus, 1993), $y=x$ is not an asymptote of $f(x)$, and in fact $f(x)$ has no asymptotes. The discussion that followed highlighted that neither the physicists nor the mathematicians were sure what asymptotes are, even though the notion of asymptote is central in secondary calculus. Moreover, the physicists found it odd that the SM curriculum focuses on the difference between two functions at infinity since it is generally far more useful to examine the ratio of two functions at infinity. The fact that the ratio of two functions may tend at infinity to 1 while the difference between the functions may tend to infinity was new to some of the teachers, and T1 shared that it revealed to her a ‘strong misconception’ she had about asymptotic behaviors of functions. Several teachers noted after the meeting that they checked with GeoGebra that they cannot distinguish between the graphs of $f(x)$ and $y = x$ when ‘zooming out’.

We recognized in this discussion an opportunity for numerical sensemaking: (Q1) What could be the advantages of each definition of asymptotic behavior (via difference or via ratio) for *approximating* functions? (Q2) What could be the rationale for focusing at secondary calculus on difference-based approximation rather than ratio-based approximation? (Q3) What could be the affordances of engaging SM students with both definitions? In the following M-Cubed session, the authors facilitated a discussion around these questions, suggesting that they warrant exploration since physicists seem to find ratio-based approximations much more useful than difference-based approximations. This rationale did not resonate at first with all the teachers. For example, T1 stated that the issue “is not interesting” since “it is a matter of definition”. Nevertheless, the teachers seemed intrigued by questions Q2 and Q3, which appealed to their expertise, and provided several insights. For example, the teachers observed that the notion of asymptote may be more appropriate for learning about functions, since it is more concrete for students, easier to verify, and more helpful for sketching graphs. One mathematician, reflecting on her teaching in undergraduate calculus courses, agreed and observed further that she uses asymptotes mostly for didactical purposes, whereas ratio convergence tests have many applications in the courses. Another teacher observed that it can be very hard for students to comprehend the difference between “convergence to zero” and “neglectable” because of the everyday uses of the word neglectable in Hebrew. While the teacher did not refer explicitly to approximations, she seemed to suggest that having more than one definition of approximation may be too difficult for SM students. The meeting concluded with several teachers noting the striking different perspectives on asymptotic behavior of functions. However, the teachers generally did not seem to see sufficient pedagogical value in bringing these different perspectives to class.

Case 2: Why approximate when we can be precise?

Often, the videotaped lessons we watched revolved around computations that involved π , e , the derivative of a function at a point, or the area under a graph. The physicists in our group observed that while the in the lessons, these computations are implicitly conceived as precise, in reality, such computations are based on approximations. To emphasize this point, the second author proposed in one M-Cubed session to engage SM students with the following question: *Calculate the area under*

the graph of $f(x) = x^2$ in the interval $0 \leq x \leq 1$, in as many ways as you can, without using antiderivatives. The participants in this session were eight SM teachers, two mathematicians, and the two authors. The participants worked on this problem in pairs for about 45 minutes, then compared various solutions and discussed implications for SM teaching. Altogether the group worked out eight solutions that represent four general approaches to calculate the area in this case, two that obtain the precise area, and two that provide approximations. In general, the problem was new to most teachers. Some teachers could not suggest any approach to work on the problem without antiderivatives, while others noted that they present in class calculations of Riemann sums with a small number of rectangles, and in some cases use technology (e.g., [Geogebra](#)) to illustrate finer approximations. However, it appears that teachers had no prior experience with calculating the limit of Riemann sums, and some teachers may have not even considered it possible to obtain a precise result or even define the integral without the use of antiderivatives. In addition, most teachers reported that Riemann sums, and more generally approximations of areas, are not addressed in class beyond the introduction of integrals (if at all), and that there is no aim of developing students' approximation skills.

Participants' perspectives about why and how this problem, or some variation of it, could be used in a SM classroom were highly diverse. Specifically, the mathematicians and physicists emphatically supported addressing this problem in class, whereas almost all the teachers rejected it, just as emphatically. For example, one mathematician argued that this is one example where students can use finite sums of areas of rectangles to obtain approximate estimates, hinting that the answer is close to $1/3$, as well as find the limit when the number of rectangles approaches infinity and be convinced that the result is precisely $1/3$, and not some other close number such as $1/\pi$. In this way they can directly appreciate the power of Riemann sums. Furthermore, the mathematician emphasized that calculating the area numerically in this case is important because the mathematics here, while perhaps not *trivial*, is still *elementary*, namely, does not rely on 'black boxes' that students are told to use without understanding. Another argument for using the problem in secondary calculus was that in practice, in physics (and in other disciplines), antiderivatives can often be too complicated to use, and that numerical approaches for approximation are used instead. The teachers saw little value in addressing this problem in class, considering the costs of doing so (e.g., class time, too difficult for most students). They also argued that the computations involved in calculating Riemann sums are not a technique that students are expected to learn, and as such have little pedagogical value. Another argument was that there are more important ideas to discuss in relation to the integral, for example discussing why it is valid to consider (an infinite number of) rectangles with zero side lengths. The main value teachers seem to find in the problem is that it may illustrate to students how complex it can be to find the area under a graph of a function, even in relatively simple cases. As a final note, after the meeting, several teachers took the problem to their class, curious to see how their students will respond, and shared with their group their students' creative solutions.

Discussion

The two cases we have described can be seen both as encouraging or as discouraging with respect to promoting numerical sensemaking in secondary calculus. The cases are encouraging in suggesting that there may be many places in the SM curriculum where a well-placed question mark could set the grounds for numerical sensemaking. Such question marks could be placed for example with respect

to implicit choices in the curriculum (e.g., learning difference-based asymptotic behavior), or with respect to deceptively trivial implications (e.g., deriving the area under the graph of $f(x) = x^2$). In both cases we presented, SM teachers appeared reluctant at first, but eventually became highly engaged in the discussion, reflected on their practice, and proposed valuable insights based on their experience and expertise. Moreover, while teachers considered some parts of the discussions to be too demanding for most of their students, they were also parts teachers considered to be well within the grasp of SM students. For example, some teachers suggested that experimenting with Riemann sums of non-linear functions could deepen students' understanding of the notion of area. Teachers also highlighted metalevel ideas that are of importance, for example that definitions in mathematics are not arbitrary, and that there could be different definitions of asymptotic behavior of functions that could be useful for different purposes. On the other side, the two cases we described are discouraging in suggesting that SM teachers do not engage students with approximation in calculus lessons and see little value in doing so as long as approximation is only a sidenote in the SM curriculum. Moreover, SM teachers themselves have little prior experience with numerical approximations, and thus likely lack knowledge needed for facilitating numerical sensemaking in their classes. Naturally, these observations are based on a small number of cases and a small number of teachers, and there is a need to further investigate them on larger scales and in additional contexts, for example in the context of a graduate numerical sensemaking course for practicing SM teachers that we are currently developing.

We conclude by calling for additional collaborations between SM teachers, mathematicians, physicists, education researchers, and other stakeholders (e.g., secondary physics teachers) that could help promote calculus education that is better aligned with the diverse roles of calculus in society.

References

- Biza, I., González-Martín, A. S., Pinto, A. (2022). 'Scaffolding' or 'filtering': A review of studies on the diverse role of calculus courses in the preparation of students, professionals and teachers. *International Journal of Research in Undergraduate Mathematics Education*, 8, 389-418. <https://doi.org/10.1007/s40753-022-00180-1>
- Eisenberg, T., & Dreyfus, T. (1993). The guide and the asymptote. *Teaching Mathematics and its Applications: An International Journal of the IMA*, 12(1), 40-42.
- Jones, S. R. (2015). Areas, anti-derivatives, and adding up pieces: Definite integrals in pure mathematics and applied science contexts. *The Journal of Mathematical Behavior*, 38, 9–28. <https://doi.org/10.1016/j.jmathb.2015.01.001>
- Pinto, A., & Cooper, J. (2022). The road not taken—Investigating affordances of infinitesimal calculus for enriching the repertoire of secondary mathematics teachers. *International Journal of Research in Undergraduate Mathematics Education*, 8, 318-338. <https://doi.org/10.1007/s40753-021-00161-w>
- Sofronas, K. S., DeFranco, T. C., Swaminathan, H., Gorgievski, N., Vinsonhaler, C., Wiseman, B., & Escolás, S. (2015). A study of Calculus instructors' perceptions of approximation as a unifying thread of the first-year Calculus. *International Journal of Research in Undergraduate Mathematics Education*, 1(3), 386-412. <https://doi.org/10.1007/s40753-015-0019-5>

Task design using a realization tree: The case of the derivative in the context of chemistry

Farzad Radmehr¹, Saeid Haghjoo² and Ebrahim Reyhani³

¹Norwegian University of Science and Technology, Norway; farzad.radmehr@ntnu.no

²Shahid Rajaee Teacher Training University, Iran; s.haghjoo@sru.ac.ir

³Shahid Rajaee Teacher Training University, Iran; e_reyhani@sru.ac.ir

Abstract. We have recently developed a realization tree for the derivative with 17 roots based on its five main representations. In this paper, we discuss how this realization tree can be used for task design, particularly when the focus of teaching is helping students realize the applications of the derivative in the real world and learning more about the physical and numerical realizations of the derivative. To achieve this goal, we have designed a task in the context of chemistry. Here, we present the task and discuss how such a rich task addresses different realizations of the derivative.

The derivative and its main five realizations

The derivative is one of the core topics in calculus with applications in various disciplines (e.g., engineering and medicine) (Hass et al., 2018). Previous studies reported that many students struggle to learn the derivative due to the complexity of its definition and various representations (in the commognition term, *realizations*) (e.g., Biza, 2021). Five main different realizations have been discussed in the literature for the derivative: symbolic (the formal definition of the derivative, the limit of a difference quotient), graphical (the slope of the tangent line), numerical ($\frac{f(x_2)-f(x_1)}{x_2-x_1}$, when Δx is very small but not let Δx approaches zero as in the formal procedure), verbal (the instantaneous rate of change), and physical (the measuring procedure prior to calculating the derivative using numerical approaches). Furthermore, for each main realization, three layers of the derivative (i.e., ratio, limit, and function) map a function into its derivative (See Rounday et al., 2015; Zandieh, 2000). Past research pointed out many students struggle to make meaningful connections between these realizations (e.g., Biza, 2021; Zandieh, 2000).

The realization tree: A tool from commognition theory

In the commognition theory, mathematics is considered a type of discourse with unique objects and ways of doing and saying (Sfard, 2008). It is distinguishable from other discourses by its four interrelated characteristics: *Word use* (e.g., differentiable function), *visual mediator* (e.g., a derivative function drawn in Desmos), *routines* (e.g., how to find the absolute extrema of a continuous function on a finite closed interval), and *endorsed narratives* (e.g., the extreme value theorem) (Sfard, 2008). In the commognition theory, the term *realization* has been used instead of the well-known term *representation*. In addition, a visual mediator in the form of a connected graph has been introduced and named *realization tree*. It is defined as a “hierarchically organized set of all the realizations of the given signifier, together with the realizations of these realizations, as well as the realizations of these latter realizations, and so forth” (Sfard, 2008, p. 301).

A realization tree for the derivative

We have developed a realization tree for the derivative at a point (See Haghjoo et al., 2023) based on the five main realizations that we pointed out above. We unpacked these five main realizations into 17 roots: two roots for numerical (e.g., N1: $f'(x) \approx \frac{f(x_0+h)-f(x_0-h)}{2h}$), three roots for symbolic (e.g., S3: $f'(x_0) = \lim_{h \rightarrow 0} \frac{f(x_0+h)-f(x_0)}{h}$), ten roots for graphical, and one root for each verbal and physical realization. Furthermore, average and instantaneous rates of change have many applications in the real world. Consequently, we identified 26 verbal realizations across eight disciplines (e.g., chemistry and biology) for the derivative by exploring a few calculus textbooks (e.g., Hass et al., 2018), such as reaction rate in chemistry (V-5).

The task: the reaction between calcium carbonate and hydrochloric acid

Task designers, when focusing on the verbal realizations of the derivative, have many contexts to choose from. However, we recommend selecting a context relevant to students' majors and future careers. Furthermore, we recommend selecting a context where measuring the dependent and independent variables is easy, not taking too much time, and, if possible, can be done by the lecturer or students in the lecture room. That makes the task very close to what is called in the literature as *tasks with authentic context* (Vos, 2020). Using such contextual tasks could make teaching more interesting for many students, especially those interested in learning mathematics because of its *use-value*. Furthermore, it gives meaning to the mathematical concepts discussed in the task, could increase the task's accessibility and may help students develop their mathematical understanding using their out-of-school/university knowledge (Vos, 2020).

In this paper, we focus on the reaction rate in chemistry for calcium carbonate and hydrochloric acid because such an experiment could be done in the classroom/lecture by taking some safety measures, and the materials needed for doing this experiment are not expensive. The chemical equation for this experiment is $\text{CaCO}_3 (s) + 2\text{HCl} (aq) \rightarrow \text{CaCl}_2 (aq) + \text{CO}_2 (g) + \text{H}_2\text{O} (l)$. When hydrochloric acid (we used a 70% solution of hydrochloric acid) is added to calcium carbonate, calcium carbonate will dissolve. Furthermore, gas bubbles will appear at the top of the solution due to the formation of carbon dioxide gas. So, the lecturer or students could calculate the reaction rate by measuring the weight of the solution over some chosen intervals. Doing so shows how much carbon dioxide gas has been released through the solution. With the help of a digital scale and a timer, we recorded the weight of the solution and consequently, according to the law of conservation of mass, we were able to record how much carbon dioxide was released (Table 1). We measured the weight of the solution in six-second intervals according to the sensitivity of the scale. The experiment ended after 36 seconds. The measuring process discussed above could help students to have a better realization of the P17 (physical realization). It also provides the necessary information for students to engage with numerical realizations of the derivative. In chemistry, it is impossible to convert the mass of one element directly (for example, in grams) to the mass of another. Instead, mass-to-mole conversion should be used. This is also true for calculating the rate of change of reactions. One mole of carbon dioxide is approximately 44 grams ($\text{CO}_2: 12 + 2 \times 16$). Therefore, to calculate the average rate of the reaction, the measured mass in grams should be converted to mol first by dividing them by 44.

T (second)	0	6	12	18	24	30	36
Weight of solution (g)	16.07	15.83	15.69	15.60	15.55	15.51	15.47
Weight of carbon dioxide (g)	0	0.24	0.38	0.47	0.52	0.56	0.60
Weight of carbon dioxide ($\text{mol} \times 10^3$)	0	5.5	8.6	10.7	11.8	12.7	13.6

Table 1: The weight of solution and carbon dioxide in our experiment

Afterwards, students can calculate the average rate of change in the six-second intervals by finding the corresponding difference quotients (e.g., $\bar{R}(\text{CO}_2) = \frac{5.5 \times 10^{-3} - 0}{6 - 0} = 0.92 \times 10^{-3}$) (Table 2).

Intervals	1 st : 0-6	2 nd : 6-12	3 rd : 12-18	4 th : 18-24	5 th : 24-30	6 th : 30-36
$\bar{R}(\text{CO}_2)$ ($\frac{\text{mol}}{\text{second}}$)	0.92×10^{-3}	0.52×10^{-3}	0.35×10^{-3}	0.18×10^{-3}	0.15×10^{-3}	0.15×10^{-3}

Table 2: The average rate of change of the reaction over six-second intervals

The next step is to focus on approximating the instantaneous rate of change of the reaction. We chose to focus on $t = 18$. We can use $N1$ and approximate the instantaneous rate of change of the reaction at $t = 18$ using the average rate of change of the reaction in the third and fourth intervals (i.e., $(0.35 \times 10^{-3} + 0.18 \times 10^{-3})/2 = 0.265 \times 10^{-3}$). The next part could focus on the graphical realizations. We can start by putting the values of carbon dioxide we measured on an $x - y$ plane on Desmos or other suitable platforms. Then ask students what would be a suitable function to fit these points. Students can manipulate themselves on the platform and try different types of functions. One of the elementary functions accessible to students and provides a reasonable approximation here is square root functions in the form of $y = a\sqrt{x}$ (See [The reaction between calcium carbonate and hydrochloric acid \(desmos.com\)](#); In this link, for convenience, the data on the y -axis is multiplied by 10^4). Then, the lecturer can suggest a few functions used more often in chemistry that fit the obtained data from the reaction much better. Two examples are natural logarithms and homographic functions. However, if students zoom in on the graph, they would realize that these functions are not the best fit for the obtained data. This could provide an opportunity for the lecturer to discuss with the students that in more advanced courses (e.g., introductory numerical analysis course), they would learn how to approximate functions based on a given set of points. Here in the Desmos link, we also included the Lagrange polynomial interpolation method. Then the lecturer could continue with a homographic or a natural logarithm function, as the polynomial obtained by the Lagrange method is complex for first-year calculus students (in our opinion).

A reasonable fit for the obtained data from the reaction is $y = 53 \ln(t + 3) - 57$; $0 \leq t \leq 36$. Its graph could be used to discuss some of the graphical realizations of the derivative with the help of Desmos, such as Zooming in on the function to discuss $G6$ and drawing secant lines to discuss $G7-10$. We can also discuss some of the symbolic realizations of the derivative with this function. For instance, the instantaneous rate of change could be estimated: $R(\text{CO}_2) = \lim_{\Delta t \rightarrow 0} \frac{\Delta n(\text{CO}_2)}{\Delta t} = \lim_{\Delta t \rightarrow 0} \frac{f(18+\Delta t) - f(18)}{\Delta t} = \frac{53}{t+3}$. Substituting $t = 18$ gives us another estimation for the derivative at this point which is $0.252 \times 10^{-3} \frac{\text{m}}{\text{s}}$; that is close to our other estimation.

Concluding words

While our suggested task is related to chemistry, such design could be used for designing tasks in other contexts. To conclude, we suggest task designers start with the physical realization, which provides the necessary information for engaging students with the numerical realizations as suggested in the literature for teaching the derivative (e.g., Eaton et al., 2019; Roundy et al., 2015). Then, the graphical, symbolic, and verbal realizations could be the focus of teaching. In our search among several textbooks used for teaching calculus (e.g., Hass et al., 2018; Hughes-Hallett et al., 2017), the physical realization was not in focus when introducing the derivative. In Hughes-Hallett et al. (2017), the derivative is first introduced in a physical context (i.e., velocity) by focusing on the numerical realizations, whereas in Hass et al. (2018), it is first introduced by graphical and symbolic realizations. We hope this work also inspires textbook developers to consider the physical realization in calculus textbooks due to its importance, as highlighted in the literature: Mathematics could be taught “like the sciences as a laboratory discipline” (Eaton et al., 2019, p. 807). This could, among other things, help students feel “more agency to readily engage with the conversation on models and modeling” (Eaton et al., 2019, p. 807).

References

- Biza, I. (2021). The discursive footprint of learning across mathematical domains: The case of the tangent line. *The Journal of Mathematical Behavior*, 62, <https://doi.org/10.1016/j.jmathb.2021.100870>
- Eaton, C. Diaz., Highlander, H. C., Dahlquist, K. D., Ledder, G., LaMar, M. D., & Schugart, R. C. (2019). A “rule-of-five” framework for models and modeling to unify mathematicians and biologists and improve student learning. *PRIMUS*, 29(8), 799–829.
- Hass, J., Heil, C. & Weir, M. (2018). *Thomas' calculus* (14th ed.). Pearson.
- Haghjoo, S., Radmehr, F., & Reyhani, E. (2023). Analyzing the written discourse in calculus textbooks over 42 years: The case of primary objects, concrete discursive objects, and a realization tree of the derivative at a point. *Educational Studies in Mathematics*, 112, 73–102.
- Hughes-Hallett, D., Gleason, A. M., McCallum, W. G., Connally, E., Flath, D. E., Kalaycioglu, S., et al. (2017). *Calculus: Single Variable* (7th ed.). Wiley.
- Roundy, D., Dray, T., Manogue, C. A., Wagner, J. F. & Weber, E. (2015). An extended theoretical framework for the concept of the derivative. In T. Fukawa-Connolly, N. E. Infante, K. Keene, & M. Zandieh (Eds.), *Proceedings of the Eighteenth Annual Conference on Research in Undergraduate Mathematics Education* (pp. 919–924).
- Sfard, A. (2008). *Thinking as communicating: Human development, the growth of discourses, and mathematizing*. Cambridge University Press.
- Vos, P. (2020). Task contexts in Dutch mathematics education. In M. Van den Heuvel-Panhuizen (Ed.) *National Reflections on the Netherlands Didactics of Mathematics* (pp. 31–53). Springer.
- Zandieh, M. (2000). A theoretical framework for analyzing student understanding of the concept of derivative. *CBMS Issues in Mathematics Education*, 8, 103–127.

What is a limit? Concept image of limits as time goes to infinity in life sciences students

Ottavio G. Rizzo

Università degli Studi di Milano, Italy; Ottavio.Rizzo@unimi.it

Math is scary. For life science students, maths is even scarier. Poor results in mathematics are amongst the main reasons for dropping out of STEM courses, particularly in life sciences — negative attitudes and disengagement being the main reasons for students' failure. In the absence of exogenous instrumentality — e.g., a good grade in calculus as a prerequisite to enter medical school — we should strive to engage students with active learning that could at least pretend to carry intrinsic motivations (Husman & al., 2004). Or, in other words, we want students to work on tasks that appear to be relevant (to them!) in order to build a conceptual understanding of the mathematical objects at stake.

The theoretical framework

Mental Pictures

A mathematical object does not exist in the real world, but only as a *concept* $C(P)$ in the mind of a person P , with $C(P)$ — the *mental picture* of C by P — consisting in a set of pictures that P associates to the name of C .

The word 'pictures' here is used in the broadest sense of the word and it includes any visual representation of the concept (even symbols). Thus a graph of a specific function and the symbols ' $y = f(x)$ ' might be included (together with many other things) in someone's mental picture of the concept of function. (Vinner, 1983)

Concept Image

A person P could likely associate a set of properties (some of them correct, some of them incorrect) to each concept: e.g., P might think that every odd function will be defined in 0, or she might think that any continuous function on $[0,1]$ has a maximum. Vinner (1983) calls these properties held by P about C together with her mental pictures of C the *concept image* (of C by P).

The definition of the concept will be just one, if any, component of the concept image held by P . Unless one requires definitions for definitions sake — “Students need to *know* the definition of continuous function in order to pass my course!”¹ — concept definitions are useful at best to help to generate concept images. Usually “concept definitions will remain inactive or even will be forgotten[;] in thinking, almost always the concept image will be evoked” (*ibidem*). “The formal definition [of a mathematical concept] should be only a conclusion of the various examples introduced to the students” (Vinner & Dreyfus, 1989).

¹ Emphasis on 'know:' 'understanding' is not really required.

The context

I have been teaching *Istituzioni di matematiche* to Natural Sciences students at the University of Milan since 2015. Students are on average quite weak, with many of them not reaching the minimal level of competence in mathematics required by the degree programme. The course has been taught using the flipped classroom since 2021, with classroom time spent working on problems (Rizzo, 2022).

Almost all students graduated from an Italian high school, hence we know that they have been exposed to some calculus (at least up to derivatives) and have spent a significant amount of time learning to sketch a qualitative graph of functions.

Limits of real functions

Following Vinner's theoretical framework, I presented the concept of $\lim_{t \rightarrow +\infty} f(t) = \ell$ in the following way: "As time goes by, the measure of $f(t)$ gets undistinguishable from ℓ : if you get hold of better instruments, it will take some more time, but eventually it will get again undistinguishable." The formal definition is then presented as a mathematization of this image, mainly in the hope that those that learned it by heart in school will now try to make some sense out of it.

Functions will always converge monotonically

I asked students the following questions (translated into English for the reader's sake)

Ovotransferrin — which makes up 12% of egg proteins — denatures at 62° C. We repeat an experiment with initial temperature $T(0) = A$ and $\lim_{t \rightarrow +\infty} T(t) = B$

- 1: If $A = 40$ and $B = 70$, what happens?
- 2: If $A = 90$ and $B = 25$, what happens?
- 3: If $A = 40$ and $B = 60$, what happens?

Students answered anonymously, using instant polling software on their phones, working in small groups or occasionally on their own. Given the classroom configuration it would have been impractical to form random groups, so they were self-selected. In Table 1 we present cumulative answers from the classes of 2021 and 2022: in total 80 students took part to the questions, divided into 41 groups.

<u>Question 1</u>		<u>Question 2</u>		<u>Question 3</u>	
		It stays boiled (but		Proteins might have	
Boiled eggs	66%	it cools down)	61%	denatured	10%
Denatured proteins	7%	A cold egg	5%	Nothing	54%
Non sensical	5%	Non sensical	5%	Non sensical	2%
No answer	22%	No answer	29%	No answer	34%

Table 1: Categorisation of students' answers

As it could be expected, questions 1 and 2 were quite easy, at least for those students that could make sense of the question. It could be interesting to notice that only 7% of students were not able to make the step from the denaturation of proteins to the albumen becoming solid. Some missing

answer can be explained by students joining the poll individually but answering collectively; given that anonymity is part of the activity design, I have no way to distinguish such a case from students giving up to peruse social networks.

Some of the answers to question 1 point to monotonical convergence to the limit 70°C , since they are quite clearly referring to Newton's law of cooling, which I presented as the first example of limit for $t \rightarrow +\infty$ (all answers are translated by the author):

For certain, it is not at 70°C since physics is not a matter of opinion.

The egg proteins degrade and have a temperature close to but not equal to 70°C .

What is interesting is analysing answers to question 3: only three groups (and only in the class of 2022) were able to postulate that the temperature function might have exceeded 62°C , and not necessarily so in a mathematical correct sentence:

The egg might have denatured if during the function the temperature passed 62 degrees, otherwise it stays as it was.

The protein might have denatured if in the interval between 40 and 60 degrees the temperature went over 62 degrees.

Ovotransferrin could have started to denature.

Notice that the last sentence could also be interpreted as pointing to a different interpretation: denaturation is actually not an on/off reaction, but a statistical one. Indeed, another answer was:

So, some proteins denature, many others don't.

Most answers claim that nothing happens to the egg, or that it just gets warmed up. Given the answers to the first two questions, we can assume that most students mean that the temperature never passes 62°C . Some answers, though, affirm more explicitly that the T increases monotonically:

The t to which it tends is not sufficient to denature proteins.

The internal temperature changes but the protein will not denature.

The protein will not denature. The egg warms up with no chemical reaction. We do not know what happens to other proteins.

Finally, some answers show that the concept of infinity as a mathematical object that stands for "given enough time" is clear:

Proteins will not denature so the egg doesn't become hard, but it will rot if left for too long.

This shows that, unless we are given a data point (for example, from the computation of stationary points) that says otherwise, most student will associate the (incorrect) mental image of monotonicity to the concept of convergence at $+\infty$.

In a neighbourhood of infinity

In the following lecture, where actual computation techniques were shown, I asked students:

Suppose that the thickness of the subcutaneous layer of fat in a brooding penguin is given, in centimetres, by the function $F(t) = \exp(-0,05t^3 + 1,8)$; which meaning can we give to the limit of $F(t)$ as $t \rightarrow +\infty$?

The 2021 and 2022 classes behaved quite differently: the former formed 9 groups out of 38 students, the latter 22 groups out of 49 students. We see in Table 2 students' answers by year.

I do not know if the larger groups of the 2021 class allowed a much greater percentage of students to *get* the answer. Yet, we see that a significant number of students read the question as if it asked to *compute* the limit, showing a concept image of limits as the result of a computation.

	2021	2022
The penguin died	44%	9%
The limit is 0 / the penguin gets thinner	22%	73%
It helps to understand what happens with time	33%	0%
There is no meaning	11%	0%
Non sensical	0%	18%

Table 2: Categorisation of students' answers

Conclusions

We can recognise three different images of the concept $\lim_{t \rightarrow +\infty}$: a computation, the value at infinity and an approximate value given enough time. As expected, no student made explicit reference to the concept definition, although many of them most likely had learned it by heart the previous year in high school. In the ovotransferrin case, where no computation was possible, most students were able to semiotically convert the mathematical meaning to the “in the model” meaning; in the penguin case this occurs to a much lesser extent: we could attribute this to the attraction of the “computation” image. If the learning of calculus has no exogenous instrumentality and has to be justified to life science students with intrinsic motivations, these could only be in relevant mathematical models. Hence, I believe in the importance of bringing the “approximate value given enough time” image to the forefront. Moreover, computational ability should not be overemphasised, but we should rather encourage critical thinking on what one could infer from the mathematical data.

Acknowledgment

This research was partially supported by “National Group for Algebraic and Geometric Structures, and their Applications.” I thank Tommy Dreyfus for his helpful suggestions in the revision.

References

- Husman, J., & al. (2004). Instrumentality, task value, and intrinsic motivation: Making sense of their independent interdependence. *Contemporary Educational Psychology*, 29(1), 63–76.
- Rizzo, O. G. (2022). We want news about Pingu: An explanatory action research case study in undergraduate service mathematics. Submitted to publication.
- Vinner, S. (1983). Concept definition, concept image and the notion of function. *International Journal of Mathematical Education in Science and Technology*, 14(3), 293–305.
- Vinner, S., & Dreyfus, T. (1989). Images and Definitions for the Concept of a Function. *Journal for Research in Mathematics Education*, 20(4), 356–366.

Chemistry as a context to investigate students' graphical conceptions of rate

Jon-Marc G. Rodriguez¹ and Slade McAfee²

¹University of Wisconsin – Milwaukee, United States; rodrigjg@uwm.edu

²University of Wisconsin – Milwaukee, United States; scmcafee@uwm.edu

Introduction

Past research in the mathematics education community has documented students' challenges with rate-related ideas – including differentiation and covariational reasoning (Rasmussen et al., 2014; Thompson & Carlson, 2017) – suggesting the need for more support to help students reason about rate of change in discipline-specific contexts (e.g., chemistry). In this report, I draw on three qualitative research studies I conducted in collaboration with colleagues that involved analyzing responses from interviews with undergraduate general chemistry students (Rodriguez et al. 2020a, 2020b, 2020c). During the interviews students were asked to interpret and draw graphs commonly encountered in chemistry. The goal of this paper is to synthesize themes, with an emphasis on implications for mathematics instruction and research on undergraduate mathematics education. Collectively, this work focuses on how students elicit information about rate from graphical representations in chemistry, with the data demonstrating similarity in reasoning across the students and across representation types (rate vs. time graph, reaction coordinate diagram, distribution graph).

Theoretical perspectives

With respect to assumptions about the nature and structure of knowledge, the collection of studies discussed in this paper were informed by a fine-grained constructivist perspective (diSessa, 1993; Elby, 2000). This cognitive model emphasizes the context-dependence of knowledge in which an emergent network of *knowledge elements* or *resources* are activated in response to features in a prompt (as opposed to knowledge being stable and unitary across contexts). Although this cognitive model has its roots in physics education research, it has been applied to a variety of disciplinary contexts, such as mathematics, biology, and chemistry. This is important because it is not just the shared content (e.g., energy) and skills (e.g., graphical reasoning) that connect our fields, it is the epistemological assumptions. Shared assumptions about the nature of knowledge (i.e., theories, frameworks, models) connect our education communities, with broad use of a framework demonstrating its utility and power in making predictions and developing explanations about how students learn and how we can better support students.

Methods

This paper draws themes from three studies. Only a brief methodological overview is provided; for more information about the details of these studies, see the cited papers. Each of the published studies involved first-year general chemistry students sampled from a university in the Midwestern United States, with the students interpreting and constructing graphical representations in an

interview context. The representations discussed are a rate vs. time graph (Rodriguez et al., 2020a), a reaction coordinate diagram (Rodriguez et al., 2020b), and a distribution graph (Rodriguez et al., 2020c). Analysis involved a combination of deductive and inductive coding to generate themes, with much of the analysis emphasizing the fine-grained intuitive ideas students associated with patterns in graphs.

Findings

Students are provided a variety of graphical representations in introductory chemistry that may look similar but are intended to be read differently. Across datasets (examples provided in Figure 1), students demonstrated similar reasoning when interpreting the graphical representations: reaction rate vs. time graph, reaction coordinate diagram, and distribution graph (number of molecules vs. speed). The students expressed a preference for eliciting trends from the graphs by focusing on a specific graphical pattern; student reasoning emphasized the idea that relative steepness provides information about rate (*steepness as rate*).

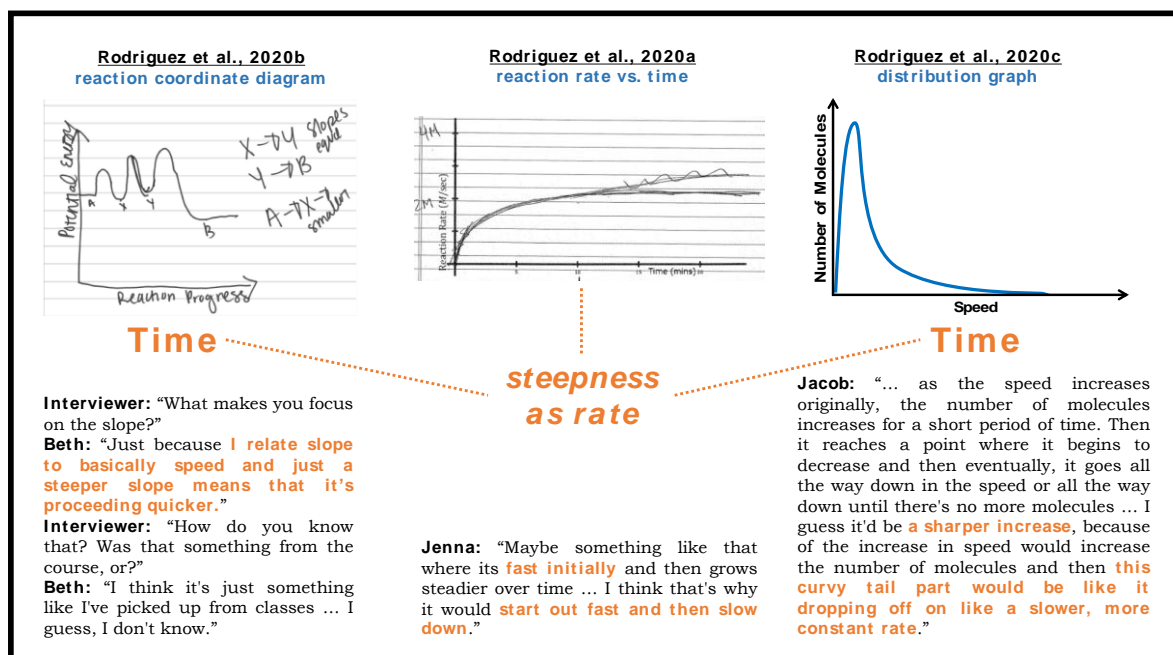

Figure 1: Students' reasoning across graphical representations

For example, Beth was prompted to describe a reaction coordinate diagram that she drew (Figure 1, left). In introductory chemistry courses, we focus on comparing the relative height of the peaks and valleys (potential energy) in the reaction coordinate diagram and the "x-axis" is effectively ignored. As the name suggests, it is better conceptualized as a one-dimensional *diagram*, not a graph. Despite the misleading surface features that suggest this is a "graph", focusing on the slope to draw conclusions about rate does not work in this context. Likewise, in Jacob's case (Figure 1, right), focusing on the relative steepness for a distribution graph will not provide information about the rate of a reaction because it is intended to be interpreted more like a histogram that describes variation in states. Moreover, although rate can be viewed as a general ratio between quantities, implicit in Beth's discussion – and explicit in Jacob's discussion – is an association between rate

and time with an unproductive mapping of time onto the x-axis as they discussed rate. In Jacob's case, his interpretation focused on reading the graph as a process that unfolds over time where the peak is an event, as opposed to viewing the peak as a measure of central tendency. Lastly, in contrast to Beth and Jacob, Jenna was prompted to interpret a graph she drew that involved time on the x-axis (Figure 1, center). For her description, Jenna emphasized a rate that is initially high but slows down, which she modeled using a steep slope followed by a curve that levels off. Based on her discussion and drawing, Jenna, like Beth and Jacob, was focusing on *steepness as rate*. Nevertheless, the graph involves rate modeled as a function of time; this means that eliciting trends about reaction rate is based on the values on the y-axis, as opposed to a ratio between y and x. Importantly, across the examples provided, the graphs reflect a context where *steepness as rate* does not "work".

Conclusion and Implications

Importantly, the common thread among the students was the use of the intuitive idea *steepness as rate*. Although space constraints limit their discussion here, across multiple qualitative studies involving students from three universities in the U.S. and one university in Sweden, I have noticed the strong phenomenological basis of intuitive graphical resources, especially *steepness as rate*. Within the resource-based perspective of knowledge, I argue that *steepness as rate* has a particularly high association with graphs for students, in which it is consistently activated in the context of graph-based prompts. Moreover, as discussed in the resources perspective, it is important to acknowledge the utility of the ideas that students have at their disposal. Focusing on relative steepness is a productive idea that works for most contexts (e.g., the rate of chemical reaction can be determined using the slope of a concentration vs. time graph); however, the problem is when students over-generalize this idea to other representation types. Thus, students need more support utilizes resources more productively.

As an implication, mathematics education and research can focus on scaffolding and guiding students to leverage the ideas they have (i.e., recognizing when steepness elicits the relevant information). In the examples provided, students seemed to be ignoring the axes and focusing on the graphical pattern. This is a trend I also observed in a biochemistry context that was further complicated because of disciplinary-specific language (e.g., biochemistry graphs involve the convention of using *velocity* on the y-axis instead of *reaction rate*) (Rodriguez & Towns, 2021). Part of the problem are the challenges related to covariational reasoning, which involves "holding in mind a sustained image of two quantities' values (magnitudes) simultaneously" (Saldanha & Thompson, 1998, p.299). That said, students would benefit from prompting that emphasizes first focusing on the axes and the information it communicates. This aligns with the mental actions and behaviors that are necessary first steps toward covariational reasoning (Carlson et al., 2002). Lastly, it is also important that coursework provides a variety of examples, particularly opportunities to reason about rate in non-time contexts (Jones, 2017) and in scenarios where rate can be conceptualized as both a value and a ratio.

Acknowledgment

Special thanks to my colleagues and co-authors, as well as the research participants.

References

- Carlson, M., Jacobs, S., Coe, E., Larsen, S., & Hsu, E. (2002). Applying covariational reasoning while modeling dynamic events: A framework and a study. *Journal for Research in Mathematics Education*, 33(5), 352–378.
- diSessa, A. A. (1993). Toward an epistemology of physics. *Cognition and Instruction*, 10(2–3), 105–225. <https://doi.org/10.1080/07370008.1985.9649008>
- Elby, A. (2000). What students' learning of representations tells us about constructivism. *The Journal of Mathematical Behavior*, 19(4), 481–502. [https://doi.org/10.1016/S0732-3123\(01\)00054-2](https://doi.org/10.1016/S0732-3123(01)00054-2)
- Jones, S. R. (2017). An exploratory study on student understandings of derivatives in real-world, non-kinematics contexts. *The Journal of Mathematical Behavior*, 45, 95–110. <https://doi.org/10.1016/j.jmathb.2016.11.002>
- Rasmussen, C., Marrongelle, K., & Borba, M. C. (2014). Research on calculus: What do we know and where do we need to go? *ZDM*, 46(4), 507–515. <https://doi.org/10.1007/s11858-014-0615-x>
- Rodriguez, J.-M. G., Harrison, A. R., & Becker, N. M. (2020a). Analyzing students' construction of graphical models: How does reaction rate change over time? *Journal of Chemical Education*, 97(11), 3948–3956. <https://doi.org/10.1021/acs.jchemed.0c01036>
- Rodriguez, J.-M. G., Stricker, A. R., & Becker, N. M. (2020b). Exploring the productive use of metonymy: Applying coordination class theory to investigate student conceptions of rate in relation to reaction coordinate diagrams. *Journal of Chemical Education*, 97(8), 2065–2077. <https://doi.org/10.1021/acs.jchemed.0c00496>
- Rodriguez, J.-M. G., Stricker, A. R., & Becker, N. M. (2020c). Students' interpretation and use of graphical representations: Insights afforded by modeling the varied population schema as a coordination class. *Chemistry Education Research and Practice*, 21(2), 536–560. <https://doi.org/10.1039/C9RP00249A>
- Rodriguez, J.-M. G., & Towns, M. H. (2021). Analysis of biochemistry students' graphical reasoning using misconceptions constructivism and fine-grained constructivism: Why assumptions about the nature and structure of knowledge matter for research and teaching. *Chemistry Education Research and Practice*, 22, 1020–1034. <https://doi.org/10.1039/D1RP00041A>
- Saldanha, L. A., & Thompson, P. W. (1998). Re-thinking covariation from a quantitative perspective: Simultaneous continuous variation. *Proceedings of the Annual Meeting of the Psychology of Mathematics Education*, 298–304.
- Thompson, P. W., & Carlson, M. P. (2017). Variation, covariation, and functions: Foundational ways of thinking mathematically. In J. Cai (Ed.), *Compendium for Research in Mathematics Education* (pp. 421–456). National Council of Teachers of Mathematics.

Mathematics education of future biologists: A strong need for brokering between mathematics and biology communities of practice

Yuriy Rogovchenko¹ and Svitlana Rogovchenko¹

¹University of Agder, Norway; yuriy.rogovchenko@uia.no; svitlana.rogovchenko@uia.no

Interdisciplinary mathematics education

For many decades, “biology education is burdened by habits from a past where biology was seen as a safe harbor for math-averse science students” (Steen, 2005, p. 14). This statement reflects a cultural gap between biologists and mathematicians briefly summarised as “what attracts students to mathematics, physics, and engineering tends to repel students who are interested in biology” (Chiel et al., 2010, p. 250). Nowadays, “mathematics enters at every stage of science: in designing an experiment, seeking response patterns, and in the search for underlying mechanisms” (Karsai & Kampis, 2010, p. 632). Research collaboration ties between mathematicians and biologists have been getting stronger during the last decades benefiting the advancement of both disciplines. Recognising the need to support the productive collaboration between mathematics and biology, high-profile reports (AAAS, 2011; National Research Council, 2009) called for a reform of biology education and a wider incorporation of quantitative concepts and skills into the biology curriculum.

Mathematics education of future biologists classifies as interdisciplinary where “closely linked concepts and skills are learned from two or more disciplines with the aim of deepening knowledge and skills” (Leung, 2020, p. 1), but it is not sufficient to introduce more mathematics courses for its improvement. Karsai and Kampis (2010) emphasized that “for mathematics to make sense in biology education, science should make first” (p. 633), and “the strongest effect of math on biology education will be the extensive use of models and simulations” (p. 636). Borromeo Ferri and Mousoulides (2018) suggested that mathematical modelling can serve as a prototype of interdisciplinary mathematics education. They stressed the importance of starting with a real-life problem and questions from another scientific discipline (p. 901) and warned that “not every interdisciplinary task, which has (some) mathematics in it, is a modelling problem per se” (p. 906). Students should work with a real modelling problem in which they understand the context and all disciplines involved and use their extra-mathematical knowledge (p. 906).

Communities of practice, boundary crossing, and brokering

Akkerman and Bakker (2011) argued that boundaries are markers of “sociocultural difference leading to discontinuity in action or interaction” (p. 133). Due to their dynamic nature, the boundaries between disciplinary communities can also carry potential for learning. Wenger (1998) introduced the construct of communities of practice (CoP) posing that learning involves participating “in the *practices* of social communities and constructing *identities* in relation to those communities” (p. 4, emphasis in original). Different academic disciplines (in our case, mathematics and biology) would claim membership of distinct CoP with distinct domains of knowledge and culture but with related professional practices. According to Wenger (1998), potential connections

between CoP may take the form of boundary encounters where participants try to understand how other practices negotiate meaning, “an ongoing forum for mutual engagement” (p. 114).

Interdisciplinary education can be significantly hindered by cultural differences grounded in epistemological differences between disciplines which might constitute a considerable challenge. Mediation between disciplines is especially important, and this role is taken by brokers who work at the boundaries between disciplines. Wenger (1998) emphasized the complexity of brokering which requires the ability to “cause learning by introducing into a practice elements of another” (p. 109). At the same time, brokers can feel like they belong to one world, to both worlds, but also to none (Akkerman & Bakker, 2011).

The research questions we discuss in this paper are: (1) *How do epistemological differences between biology and mathematics CoP hinder students’ work on a modelling task?* (2) *How can brokering at the boundary between the two CoP facilitate students’ learning?*

Modelling task

We analysed students’ work on an open-ended task offered to a group of twelve undergraduate biology students (9 female and 3 male) at a Norwegian university. All students were concurrently enrolled in a compulsory first-semester mathematics course and did not have previous modelling experience. This task is one of many suggested to students during five three-hour extra-curricular modelling sessions whose main goal was to show students how simple mathematical tools can be used to solve meaningful biological tasks thus increasing students’ motivation to learn more mathematics. The task “Rabbits on the Road” was selected from a popular book on ecological modelling written by a renowned ecology professor who also suggested problem’s solution which was adopted by the second author for the discussion in the class (Harte, 1988, pp. 211-213). Two small groups of students worked on the problem for forty minutes. Their work was recorded, transcribed, and analysed. During the analysis of students’ discussions, substantial distinctions between the views on the concept of population density between biologists and mathematicians came into focus which, in turn, pointed towards differences in the views of two CoP on modelling.

Problem A. Driving across Nevada, you count 97 dead but still easily recognizable jackrabbits on a 200-km stretch of Highway 50. Along the same stretch of highway, 28 vehicles passed you going the opposite way. What is the approximate density of the rabbit population to which the killed ones belonged?

More details about the choice of problems and organization of students’ work can be found in Rogovchenko (2021); for commognitive analysis of tensions between ritualized and exploratory discourses in students’ work on Problem A, we refer to Viirman and Nardi (2019).

Multiple faces of population density

The modelling task turned out to be challenging for students. An explanation for this comes from the definition of population density in McArdle (2001) according to which mathematicians learn the following. First, population density is often used in biology as a measure of organisms’ response to local conditions which is new and nonessential to mathematicians but attracts students’ attention to details not needed for solution. Second, density can be used as “an explicit proxy for population

size” and “the link between population density and population size is not always direct” (McArdle, 2001). This is why students were unsure how to use the data collected along a highway. Third, if the area includes the entire population (say, an island), the density times area gives the total population size, otherwise “density simply gives the number of organisms present in some defined study area” (McArdle, 2001). Although the problem comes from a book written by the ecology professor (Harte, 1988), these issues were not taken into consideration, and a mathematics professor did not reflect about them either while choosing the task for the first session with the students.

Population density for mathematicians means the number of individuals divided by the area they inhabit. Mathematicians perform this calculation with ease and would have also used the same definition in Problem A. Further mathematical complications with the concept of density are based on an implicit assumption of homogeneous mixing, not acceptable for most biologists. One can find the total population introducing a radial density function $\rho(r)$ and using a definite integral (Rogawski & Adams, 2018, p. 385) and even by employing a multivariable density function $\rho(x,y)$ and calculating a double integral (Buono, pp. 198-199).

Different views of two communities on models and modelling

There are important epistemological distinctions between the views of mathematics and biology CoP on mathematical models and modelling that influence their approaches to modeling tasks. First, biologists are usually trained to choose exactly that model from those available which fits experimental data the best. They lack experience in modifying existing models or creating new ones. Second, biologists tend to adopt a holistic approach to biological systems and experience difficulties when they have to decide what aspects of a biological system should be excluded and what assumptions should be imposed. Third, “in the science education literature modelling tasks often emphasize the need for students to fit real systems or match some existing target model,” and if this is the only purpose, “important aspects of productive scientific thought will be neglected” (Svoboda & Passmore, 2011, p. 16). Fourth, complexity of biological systems requires developing the feeling of the entire organism which may not be easily quantified (Chiel et al., 2010, p. 249).

Discussion and conclusions

Biology undergraduates experienced difficulties with a modeling task induced by their professional training as biologists and not known to mathematicians, a situation where views of two CoP on the same concept differed significantly. We argue that the attention of mathematicians to biological details and active brokering can facilitate students’ learning of mathematics. Boundary practices can become a “longer-term way of connecting communities in order to coordinate perspectives and resolve problems” (Goos & Bennison, 2018, p. 259).

Acknowledgment

The authors gratefully acknowledge unfailing support of two Norwegian centres for excellence in higher education, the Centre for Research, Innovation and Coordination of Mathematics Teaching (MatRIC) and the Centre for Excellence in Biology Education (bioCEED).

References

AAAS (2011). Vision and Change in Undergraduate Biology Education: A Call to Action. AAAS.

- Akkerman, S., & Bakker, A. (2011). Boundary crossing and boundary objects. *Review of Educational Research*, 81, 132-169.
- Borromeo Ferri, R., & Mousoulides, N. (2018). Mathematical modelling as a prototype for interdisciplinary mathematics education? – Theoretical reflections. CERME10, Feb 2017, Dublin, Ireland. hal-01933490
- Chiel, H. J., McManus, J. M., & Shaw, K. M. (2010). From biology to mathematical models and back: teaching modeling to biology students, and biology to math and engineering students. *CBE-Life Sciences Education*, 9(3), 248–265.
- Goos, M., & Bennison, A. (2018). Boundary crossing and brokering between disciplines in pre-service mathematics teacher education. *Math Ed Res J* 30, 255–275.
- Gunawardena, J. (2014). Models in biology: ‘accurate descriptions of our pathetic thinking.’ *BMC Biology* 12, 29. <https://doi.org/10.1186/1741-7007-12-29>
- Harline, K., Martínez-Gómez, J., Specht, C.D., & Roeder, A.H.K. (2021). A life cycle for modeling biology at different scales, *Frontiers in Plant Science* (12).
- Harte, J. (1988). *Consider a spherical cow. A course in environmental problem solving*, University Science Books.
- Karsai, I. & Kamps, G. (2010). The crossroads between biology and mathematics: the scientific method as the basics of scientific literacy, *BioScience*, 60(8), 632–638.
- Leung, A. (2020). Boundary crossing pedagogy in STEM education. *International Journal of STEM Education*. 7 (15).
- National Research Council (2009). *A new biology for the 21st century*. The National Academies Press.
- Rogovchenko, Y. (2021). Mathematical modelling with biology undergraduates: Balancing task difficulty and level of support. In: Leung, F.K.S., Stillman, G.A., Kaiser, G., Wong, K.L. (eds) *Mathematical modelling education in East and West*. Springer, 571-582.
- Steen, L.A. (2005). The “gift” of mathematics in the era of biology. In L.A. Steen (Ed.), *Math and bio2010: Linking undergraduate disciplines*, (pp. 13-25). The Mathematical Association of America.
- Svoboda, J. & Passmore, C. (2013). The strategies of modeling in biology education. *Science & Education* 22, 119–142.
- Viirman, O. & Nardi, E. (2019). Negotiating different disciplinary discourses: biology students’ ritualized and exploratory participation in mathematical modeling activities. *Educational Studies in Mathematics* 101, 233–252.
- Wenger, E. (1998). *Communities of practice: learning, meaning, and identity*. Cambridge University Press.

Mathematics and engineering: Interplay between praxeologies

Frode Rønning

Norwegian University of Science and Technology, Trondheim, Norway; frode.ronning@ntnu.no

Introduction

There are several on-going initiatives aiming at strengthening the connection between mathematics and applications in engineering, both within the study programmes and between the study programmes and work life. The CDIO (Conceive, Design, Implement, Operate <http://www.cdio.org>) approach has formulated some general principles for engineering education, such as the principle of *contextual learning*: “Concepts ... are presented in the context of their use”, and “[e]xamples include believable situations that students recognize as being important to their current or possible future lives” (Crawley et al., 2014, pp. 32-33). In the CDIO approach, a deep working knowledge and conceptual understanding are emphasised (Crawley et al., 2014, p. 13). This may be interpreted in the way that to use mathematics in engineering contexts requires understanding of mathematics at the level of *studied reflection*; “[t]o be able to use mathematics to solve problems” and “[t]o understand how mathematics applies to other situations” (Booth, 2004, p. 25). The idea of contextual learning can also be seen as one possible answer to challenges with mathematics in engineering education connected to students not seeing the relevance of the mathematics they are expected to learn (González-Martín, 2021). Findings show that students find it challenging to apply mathematics they have learnt when they need it in engineering courses (Carvalho & Oliviera, 2018).

This paper is based on a collaborative project between mathematics and electrical engineering. The participating students are in their first year of the Master of Technology (MT) programme Electronic Systems Design and Innovation. I will present an example from the project showing that engineering problems may require (rather advanced) mathematical knowledge to be solved. However, also deep knowledge from the engineering field is necessary to model the problem in mathematical terms. Following the Anthropological Theory of the Didactic (ATD), I see mathematics and engineering as two institutions, each with their own praxeology, Π_M (mathematics) and Π_E (engineering). The analysis of the example shows that to answer the generating question, arising in Π_E , essential elements from both Π_M and Π_E are required. I will write $\Pi_i = [P_i/L_i] = [T_i, \tau_i, \theta_i, \Theta_i]$, $i = E$ or M , according to standard notation in ATD (Bosch & Gascón, 2014). The interplay between praxeologies in the same project is further elaborated in Rønning (2022). Other authors have also discussed interplay between praxeologies. To this end, Peters et al. (2017) introduce what they call an extended praxeological ATD-model, and González-Martín (2021) discusses the use of integrals in engineering. He also links this to the issue of relevance of mathematics for engineering.

To investigate whether the context-based teaching affects the students’ perceived relevance of mathematics, a survey was distributed in the spring of 2022 both to the students within the project and to all other first-year MT students. Some results are shown at the end of the paper.

The example

The fundamental example is the oscillator circuit shown in Figure 1, and the generating question Q is to determine the output voltage y . This circuit is an extension of the simpler circuit shown in Figure 2 which contains an amplifier, described by the linear relation $z = Gy$, where G is a positive number and y is the voltage. The circuit in Figure 1 was used as an example both in the mathematics course and in an electronics course running in parallel. In the electronics course, the students built the circuit from physical components, and they could observe its behaviour. To answer Q , the students can do measurements (τ_E) but to explain *why* the output behaves as it does, mathematical concepts and techniques (τ_M) are necessary. Furthermore, to explain why the mathematical techniques work, a mathematical technology (θ_M) is required. This can be seen as an interplay between the praxeologies Π_M and Π_E where the mathematical understanding is lifted to the level of studied reflection (Booth, 2004). I will now discuss the two circuits more in detail to see how the praxeologies interact. The circuit in Figure 2 can be modelled with the differential equation (1) (Lundheim, 2021).

$$(1) y'' + (1 - G)\frac{R}{L}y' + \frac{1}{LC}y = 0.$$

This differential equation can be solved using analytic methods, and the solution can be written

$$y(t) = e^{-\delta t}(A \sin(\omega t) + B \cos(\omega t)),$$

where $\delta = (1 - G)R/2L$ and $\omega = \sqrt{1/LC - \delta^2}$. Modelling the circuit requires knowledge from Π_E , and solving the differential equation (1) requires knowledge from Π_M . It follows that when $G = 1$, harmonic oscillations are obtained. When $G < 1$ ($\delta > 0$), $|y(t)| \rightarrow 0$, the oscillations will die out. When $G > 1$ ($\delta < 0$), $|y(t)| \rightarrow \infty$, the system will be unstable.

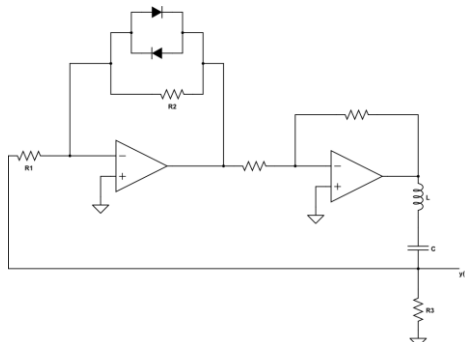

Figure 1. The oscillator

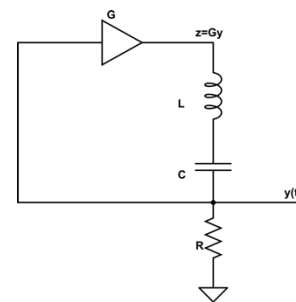

Figure 2. A simple circuit

From an engineering point of view, stable oscillations that do not die out are desirable, so one would like to set the constant G in the amplifier equal to 1. In Π_M one could say “assume $G = 1$ ”, and then proceed. However, the engineer knows (Π_E) that keeping the number G exactly equal to 1, is impossible in practice, so it is necessary to modify the circuit by introducing new elements in it, which is how the circuit in Figure 1 is created. Without going into details, I will only say that this modification results in a non-linear model. This modification requires knowledge both from the praxis block and the logos block of Π_E . Mathematically, the modification means that the linear function $z = Gy$ is replaced with $z = g(y)$. The equation (1) then turns into

$$(2) \quad y'' + (1 - g'(y)) \frac{R}{L} y' + \frac{1}{LC} y = 0.$$

The inverse of the function g can be explicitly written as

$$g^{-1}(y) = 2R_1 I_0 \sinh\left(\frac{y}{V_0}\right) + \frac{1}{R_2} y.$$

This follows from properties of the elements of the circuit (Lundheim, 2021). The constants in the expressions come from the specifications of the components in the circuit. To formulate the equation (2) and the expression for g^{-1} knowledge both from Π_E and Π_M is necessary. As a result of the modification, the mathematical problem has changed to the non-linear differential equation (2) instead of the linear equation (1). This challenges both the praxis block and the logos block of Π_M : Does the equation have a solution (L_M) and if so, how can it be solved (P_M)? The equation (2) is a special case of Lienard's equation, and Lienard's theorem gives conditions, which are part of L_M , for this equation to have a stable limit cycle (see e.g., Lins et al., 1977, pp. 335-336). To solve (2), it is necessary to use numerical methods, and to this end, the equation must be rewritten into a system of first order equations, which can be solved (P_M) using e.g., the symplectic Euler method (Hairer & Wanner, 2015). Note that since an explicit expression for g^{-1} is known, one can find an expression for g' by differentiating g^{-1} without having an expression for g itself, using the Chain Rule (L_M).

Discussion

Traditionally, students in their first year will encounter only analytic methods for solving second order differential equations with constant coefficients, like equation (1). Numerical methods are usually at this stage restricted to simple methods (e.g., Euler's method) for solving the first order initial value problem $y' = f(x, y), y(0) = y_0$. Solving systems is also at this stage usually restricted to linear systems. Seen from a mathematical point of view, these choices are natural since they give simple, elegant solutions and they show how various parts of mathematics are useful, such as complex numbers, or eigenvalues and eigenvectors of matrices. However, from an engineering point of view, these methods have limited value since they can only be applied to situations which are not so often found in real engineering applications, or in engineering courses, as the example with the oscillator in Figure 1 shows. The possible discrepancy between the classical methods (τ_M) from Π_M and the relevant applications (T_E) in Π_E raises the question of *relevance* of mathematics for engineering. The table below shows answers to two of the statements presented in the survey. The percentages in boldface show the results from the students within the project ($n = 45$) and those in normal font in parenthesis show the results from the rest of the students ($n = 494$).

	Completely agree	Partly agree	Partly disagree	Completely disagree
In my work with other courses (i.e., not mathematics courses), I have seen the importance of learning mathematics.	85 % (37 %)	13 % (44 %)	0 % (14 %)	0 % (5 %)
I don't think the mathematics I have learned is very relevant for my study programme.	2 % (5 %)	2 % (25 %)	18 % (44 %)	78 % (26 %)

These results indicate that working with mathematics in context may increase the perceived relevance of mathematics. Currently, more programmes have been included in the project, and by repeating the survey, one may see whether the responses from the newly included programmes have changed.

References

- Booth, S. (2004). Learning and teaching for understanding mathematics. In M. Demlová (Ed.), *Proceedings of the 12th SEFI Maths Working Group Seminar* (pp. 12-25). European Society for Engineering Education (SEFI).
- Bosch, M., & Gascón, J. (2014). Introduction to the anthropological theory of the didactic (ATD). In A. Bikner-Ahsbahr & S. Prediger (Eds.), *Networking of theories as a research practice in mathematics education* (pp. 67-83). Springer.
- Carvalho, P., & Oliveira, P. (2018). Mathematics or mathematics for engineering? In *Proceedings from 2018 3rd International Conference of the Portuguese Society for Engineering Education (CISPEE)*. <https://ieeexplore.ieee.org/document/8593463/authors#authors>
- Crawley, E. F., Malmqvist, J., Östlund, S., Brodeur, D. R., & Edström, K. (2014). *Rethinking engineering education. The CDIO approach* (2nd Ed.). Springer.
- González-Martín, A. S. (2021). $V_B - V_A = \int_A^B f(x)dx$. The use of integrals in engineering programmes: A praxeological analysis of textbooks and teaching practices in strength of materials and magnetism courses. *International Journal for Research in Undergraduate Mathematics*, 7(2), 211-234.
- Hairer, E., & Wanner, G. (2015). Euler methods, explicit, implicit, symplectic. In B. Engquist (Ed.), *Encyclopedia of applied and computational mathematics* (pp. 451-455). Springer.
- Lins, A., Melo, W. d., & Pugh, C. C. (1977). On Liénard's equation. In J. Palis & M. do Carmo (Eds.), *Geometry and topology, III Latin American School of Mathematics* (pp. 335-357). Springer-Verlag.
- Lundheim, L. (2021). *Oscillatorar, tilbakekopling, difflikningar, dynamiske system og litt til*. [Oscillators, feedback, differential equations, dynamical systems and some more]. Lecture notes for TTT4265 Electronic systems design and analysis I/II, Trondheim, NTNU.
- Peters, J., Hochmuth, R., & Schreiber, S. (2017). Applying an extended praxeological ATD-model for analyzing different mathematical discourses in higher engineering courses. In R. Göller, R. Biehler, R. Hochmuth, & H.-G. Rück (Eds.), *Didactics of mathematics in higher education as a scientific discipline. Conference proceedings* (pp. 172–178). University of Kassel.
- Rønning, F. (2022). Learning mathematics in a context of electrical engineering. In R. Biehler, M. Liebendörfer, G. Guedet, C. Rasmussen, & C. Winsløw (Eds.), *Practice-oriented research in tertiary mathematics education* (pp. 603-620). Springer.

Connecting mathematics and economics: the case of the integral

Matija Bašić¹, [Željka Milin Šipuš](#)¹

¹University of Zagreb, Faculty of Science, Department of Mathematics, Zagreb, Croatia;
mbasic@math.hr milin@math.hr

Introduction

Mathematics has an inevitable role in economics, reflected both in education and in the workplace of economist. Mathematics courses for economics students usually offer contents including fundamentals of calculus and linear algebra, but also advanced mathematics theories for various economic purposes (e.g., Ariza, Llinares & Valls, 2015; Feudel & Biehler, 2021; Żylicz, 2006). They can be further shaped by the extensive use of technology which reduces demands on the ability to perform (lengthy) procedures and requires a deeper understanding of concepts. Despite all the above, as reported in mathematics education areas for non-specialists, “invisibility of mathematics”, especially in the workplace, leads “to question the prominence of mathematics in [...] education” (González-Martín, Gueudet, Barquero, & Romo-Vázquez, 2021). While there are a number of research papers that attempt to understand fundamental economics concepts developed on the mathematical concept of derivative (e.g., Ariza et al., 2015; Feudel & Biehler 2021; Landgärds, 2018), research papers on integral calculus seem to be less present. The present study attempts to tackle this problem by posing a question from the field of financial literacy where the required answer basically draws on the integral (or summation). In mathematics, the content of integral has two main organizations: it appears as the “antiderivative” (in definition of the indefinite integral, with the techniques how to determine it), and as “indefinite sums” (Riemann sums, in definition of the definite integral, with the interpretation as an “area under the graph”), which are (magnificently) related to by the Fundamental Theorem of Calculus. The latter organization further induces the aspect of integral as the “total amount of a changing quantity” in various contexts of application. Thus, in the context of civil engineering, González-Martín and Hernandez-Gomes (2018) reported that the professional “textbook’s tasks do not require students to use techniques typically introduced in a traditional calculus course”, which is also the starting point of this study.

Motivation, research question and theoretical framework

In winter semester of the academic year 2022/2023 the authors conducted workshops for graduate students of mathematics and mathematics education on financial literacy with the goal to enhance their understanding of underlying mathematics to successfully cope with the challenges of teaching these topics in school, but also to enhance their financial literacy. One of the topics covered was “Annuity vs. installment”. Resources presented in Figure 1, were found on the website of a financial portal (Moj bankar, 2022), where it is also stated that by repaying the loan in installments, the total amount repaid is lower than in annuities. Students were asked to justify the claim written in the text using the given graph. Our motivation for this study comes from these discussions, where students generally did not justify the *total amount repaid* with summations or integrals. Students who argued mathematically mostly based their answers on the position of the intersection of the two lines: “before half of the repayment time, the installment becomes lower than the annuity”, “most of the blue graph is below the red one”. Others did not find the graph informative enough: “this text would

not help me too much, because it is too concise”, “calculation is missing”, “it depends on how a person wants to organize his life”. The discussion with these students triggered us to explore the potential that the task could offer in teaching economics students. Therefore, our question is: What role could this task have in the teaching of integrals, as seen by the mathematics teacher and the economics teacher? What other mathematics concepts or ideas teachers refer to in their analysis?

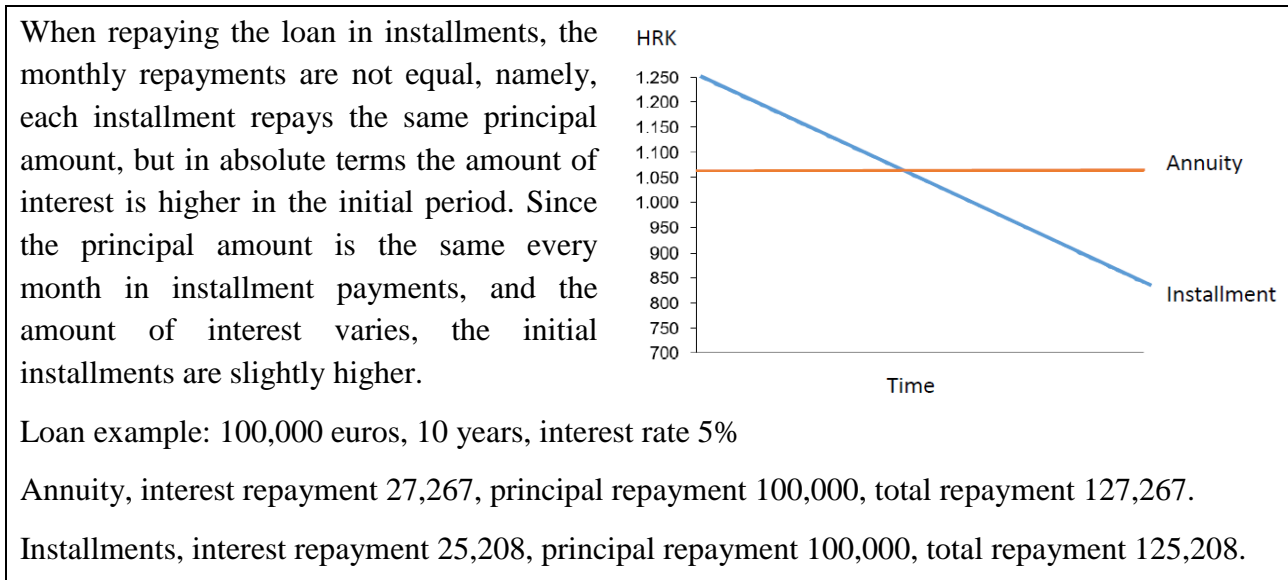

Figure 1: Monthly loan repayment in annuities and installments

This study draws on the Anthropological Theory of the Didactic (ATD) as a theoretical framework since it pays special attention to the institutional construction of knowledge (Chevallard, 1991). We observe two different institutions – institution of mathematical courses and institution of economics courses targeting the workplace of economist, and the circulation of praxeologies between them. Analysis of praxeologies, as a set of a theory (*logos*) and practical work (*praxis*) that shape certain knowledge, and are developed by both institutions separately, brings a powerful insight into their practices. The first step is the analysis of a certain *punctual praxeology*, which is organized around the *type of tasks* within a piece of knowledge, followed by the *technique* to carry them out (as part of the praxis block) and *technology* with underlying *theory* that describe and justify the technique (as part of the logos block) is to be initiated with this study.

Context of the study

For our purpose we interviewed two teachers from a faculty of economy to gain insight into practices of institutions: a mathematics teacher, an assistant professor, with 20 years of experience in teaching introductory mathematics to economics students, and an economics teacher, a full professor, who teaches Principal of economics, Microeconomics and other specialized subjects for graduate and postgraduate students for more than 15 years. They participated in separate interviews conducted by the second author, which lasted about half an hour.

After they were shown a graph from the website of a financial portal, the interviewer asked the following questions: Is this graph important to be understood or produced by a future economist, e.g., a person working with clients in a bank? What method of justification would you like or expect

your students to use? In what way would you like the teaching of mathematics to contribute to this? Do you use or would you like to use such a graph in teaching mathematics? Would you present the given problem graphically in a different way? Do you handle this problem with the accompanying mathematics by means of formulas? Do you comment in this problem, for example, on the "total amount repaid"? In general, to what extent and how economic concepts are used in mathematics lessons? Which concept are discussed? What is the prior knowledge of your students for introductory mathematics classes and how do you adapt?

Results and discussion

As found in the interview with a mathematics teacher, introductory mathematics course is offered in the first term only, which is a significant reduction compared to the previous program carried out at that faculty. It comprises mathematical content of single variable calculus and linear algebra. Regarding the loan repayment, students are required to produce repayment tables consisting of monthly payments of principal sum and interest, and total amount repaid, by using formulas for prenumerando and postnumerando payment. This topic does not appear again among economic topics that are introduced in calculus (e.g., marginal cost, total cost, demand function, elasticity of demand). When working with the concept of integral, the teacher argues that he cannot rely on the students' prior knowledge, as most of them did not learn it in school. According to syllabus, the integral is primarily seen as the antiderivative, with the *techniques* for its determination (method of substitution, partial integration), so "this particular example would certainly fit in well". He finds that the given graph lacks a certain mathematical precision since discrete data are shown as continuous. Further he argues that it is very enriching to perform a dimensional analysis of involved variables - in this task it would indicate some lack of descriptions of variables. He does that with graduate students, however, due to lack of sound mathematical pre-knowledge it is "out of reach" of undergraduate students and "out of time" for him as a teacher.

Upon inspecting a graph, the economics teacher comments that it gives just a vague idea of the total amounts repaid in these cases. For him, the issue of a consumer's choice is not related exclusively to the total amount repaid, but to his life context, that is, "at which point in life he is". Besides, he stresses that it is very important to consider inflation and discounted values of all amounts. In this situation in the workplace, he considers the use of graphs to be less important and points out that what is important is what mathematics can accurately provide, namely the exact amounts and payment tables. Still, "this [graph] is relatively OK. For an ordinary person, this can bring him closer to the idea." Even "those graphs make sense in introductory education... Things in the first year of mathematics courses are crucial for a person to take them further, the rest are upgrades". The economics teacher argues a great deal on the use of different representations: "In economics, we say that there are three languages: verbal, mathematical and graphic. Today students work very little in mathematical language, and they are very weak in it. So, we do some things at the graph level".

Both teachers discussed this seemingly underspecified task from the perspective of their discipline and found that the required answer of the task can be better understood by doing calculations than

from the graph. “Mathematics is required to bring precision.” Interestingly, idea of the integral was not much discussed by none of the teachers, supposedly due to the curriculum restrictions.

In mathematics education for non-specialists it is always a challenge to meet the other discipline in a non-trivial way. This example aims at a better understanding of (a fragment of) the mathematics that appears in the workplace of economists as their possibly relevant knowledge. In terms of praxeologies, a possible *technique* for solving this task is the (geometric) calculation the “area under the graph”. However, as can be seen from the interview with the mathematics teacher, this technique is not available to students from their high school education, neither is its evocation highlighted in the mathematics course when calculating the *total amount* in the context (of economics), although the teacher finds that *it fits*. Regarding economics and the introductory courses of mathematics, we discuss whether simple ideas from *financial literacy* could provide a common ground for a meeting point, while at the same time bringing relevant mathematical ideas. This particularly concerns the use of different representations (or more widely *ostensives* in the terms of ATD), especially connecting verbal and graphic ones to symbols and formulas, which possibly reduces the gap between mathematics and its use in the workplace, which is to be explored in future.

References

- Ariza A., Llinares S., & Valls, J. (2015). Students’ understanding of the function-derivative relationship when learning economic concepts, *Mathematics Education Research Journal*, 27, 615–635. <https://doi.org/10.1007/s13394-015-0156-9>
- Chevallard, Y. (1991). *La transposition didactique – Du savoir savant au savoir enseigné*. (2e) La Pensée sauvage, Grenoble.
- Feudel, F., & Biehler, R. (2021). Students’ Understanding of the Derivative Concept in the Context of Mathematics for Economics, *Journal für Mathematik-Didaktik*, 42, 273–305 <https://doi.org/10.1007/s13138-020-00174-z>
- González-Martin, A. S., & Hernandez-Gomes, G. (2018). The use of integrals in Mechanics of Materials textbooks for engineering students: the case of the first moment of an area. *INDRUM 2018, INDRUM Network*, University of Agder, Apr 2018, Kristiansand, Norway. (hal-01849540)
- González-Martín, A., Gueudet, G., Barquero, B., & Romo-Vázquez, A. (2021). Mathematics and other disciplines, and the role of modelling, Advances and challenges, Chapter in the book Viviane Durand-Guerrier, Reinhard Hochmuth, Elena Nardi, Carl Winsløw (Eds). *Research and Development in University Mathematics Education*, <https://doi.org/10.4324/9780429346859>
- Landgärds, I. (2018). Mathematics Teaching for Economics Students, But How? *INDRUM 2018, INDRUM Network*, University of Agder, Apr 2018, Kristiansand, Norway. (hal-01849957)
- Moj bankar. (2022, October 8). *Anuitet ili rata? U čemu je razlika*. <https://www.moj-bankar.hr/Vijesti/Anuitet-ili-rata-u-cemu-je-razlika>
- Żylicz, T. (2006). Should Economics Students Be Taught Mathematics? *Warsaw University, Faculty of Economics*, coin.wne.uw.edu.pl/tzylicz/mathecon.pdf

How students reason with derivatives of vector field diagrams

Zeynep Topdemir¹, John R. Thompson² and Michael E. Loverude³

¹University of Maine, United States; zeynep.topdemir@maine.edu

²University of Maine, United States; thompsonj@maine.edu

³California State University - Fullerton, United States; mloverude@fullerton.edu

Introduction

Students are introduced to vector fields in introductory courses, typically in the contexts of electric and magnetic fields. Vector calculus provides several ways to describe how vector fields vary in space including the gradient, divergence, and curl of a vector field. Students who major in physics use vector calculus extensively in a junior-level electricity and magnetism course. Our focus here is exploring student reasoning with the partial derivatives that constitute the expressions for divergence and curl of vector field representations, which adds to the current understanding of how students reason with derivatives.

Background

Several previous studies in physics education research (PER) have examined student understanding of divergence and curl in post-introductory courses (Baily & Astolfi, 2014; Bollen et al., 2015; Gire & Price, 2012; Singh & Maries, 2013). These studies involved two-dimensional representations of a field as an array of vectors and asked students to determine the divergence and/or curl from these representations. Singh and Maries (2013) reported that even graduate students successfully calculating the divergence and curl of vector field functions were unable to interpret the divergence and curl of vector field plots. Baily and Astolfi (2014) and Bollen et al. (2015) performed similar studies with different diagrams and reported that around 50% of their students could correctly determine whether the divergence and curl of the vector field diagrams are zero or not.

Previous studies have asked students to determine the sign or value of the divergence and/or curl for a given field diagram, but there has not been as much focus on the partial derivatives that constitute these operations, e.g., $\frac{\partial v_x}{\partial x}$ and $\frac{\partial v_y}{\partial y}$ for divergence or $\frac{\partial v_x}{\partial y}$ and $\frac{\partial v_y}{\partial x}$ for curl in Cartesian coordinates. This study explores student understanding of constituent derivatives of divergence and curl of vector field representations.

Zandieh (2000) developed a theoretical framework for student understanding of derivatives, which was extended by Roundy et al. (2015) to include partial derivatives. Wangberg and Gire (2019) investigated student understanding of partial derivatives of scalar fields represented as surfaces using Zandieh's framework. These existing works are restricted to derivatives of scalar functions and need to be extended to derivatives of vector quantities.

Study and setting

Written data was collected in the Mathematical Methods for Physics course, an intermediate course intended to prepare students for the advanced mathematics they will encounter in upper-level physics courses. All students had completed introductory sequences in both physics and calculus,

and the data were collected in the course after instruction on vector calculus. In our tasks, students were shown a 2-d field representation (see Figure 1) and asked to determine the signs first of the divergence and curl, then of the constituent derivatives. Field 1 (N=14) and Field 2 (N=32) were asked in different semesters at two public universities and due to small N, data are combined here. In this paper, only the results of constituent derivatives will be discussed.

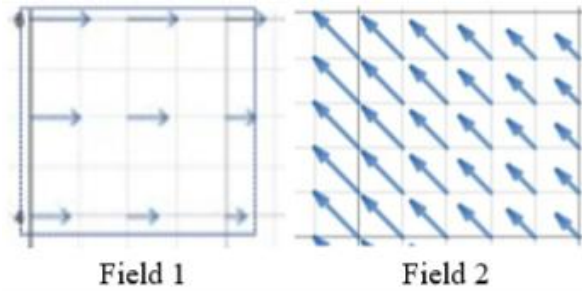

Figure 1: Vector field diagrams used in this study

Results and discussion

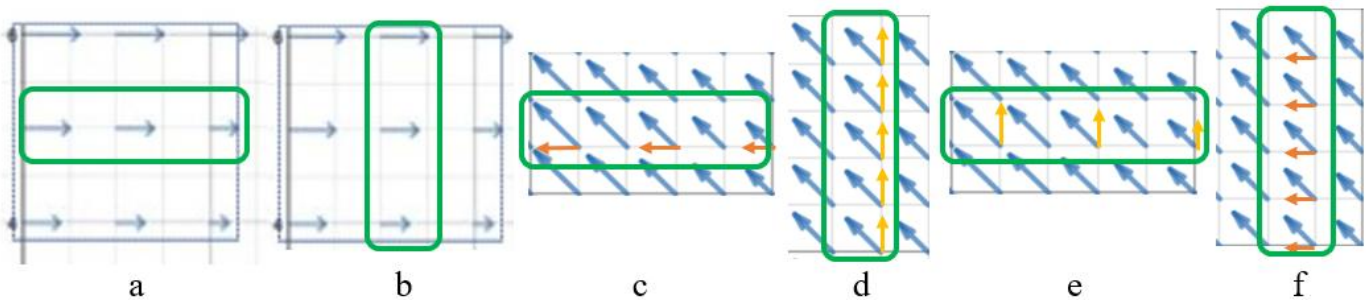

Figure 2: The figures for the tasks, with the components of the vector fields that students are expected to examine to determine. The lighter colored arrows are the components in the direction of interest:

$\frac{\partial V_x}{\partial x}$ and $\frac{\partial V_y}{\partial x}$ for Field 1 in a and b respectively, $\frac{\partial V_x}{\partial x}$, $\frac{\partial V_y}{\partial y}$, $\frac{\partial V_y}{\partial x}$ and $\frac{\partial V_x}{\partial y}$ for Field 2 in c, d, e, and f, respectively

Constituent derivatives for divergence

To determine the partial derivatives of the vector fields, students were first expected to determine which component to consider and then identify how that component changes with respect to the corresponding direction in the denominator (see Figure 2). The first field has only V_x components and students were only asked to determine $\frac{\partial V_x}{\partial x}$. For Field 1, 9 of 14 students were able to identify the change in V_x with respect to the x -direction. Somewhat surprisingly, determining $\frac{\partial V_x}{\partial x}$ for Field 2 was more challenging: only 34% (N=32) of the students answered correctly. An example of the most common incorrect reasoning was “arrows get smaller in the x -component as you move towards positive dx direction”. In a previous report, we have suggested that some students recognize that the magnitude of the vector is decreasing, but do not account for the negative direction of the vector and thus find the sign of $\frac{\partial V_x}{\partial x}$ to be negative (Topdemir et al., 2023). More students correctly determined $\frac{\partial V_y}{\partial y}$ to be zero for Field 2 (78%).

Constituent derivatives for curl

The constituent derivatives for curl are ‘mixed’ in that the component that is differentiated does not match the coordinate with respect to which one differentiates (i.e., $\frac{\partial V_x}{\partial y}$ as opposed to $\frac{\partial V_x}{\partial x}$). For Field 1, only 2 of 14 students were able to identify the change in V_x with respect to the y -direction. For Field 2, more than 72% of the students (N=32) answered each of $\frac{\partial V_x}{\partial y}$ and $\frac{\partial V_y}{\partial x}$ correctly, but only 50% answered both derivatives correctly. When finding $\frac{\partial V_x}{\partial y}$ for Field 1, some student responses suggested incorrect notation mapping (see Figure 3a), with explanations consistent with reversed components and variables. For example, the explanation for the sign of $\frac{\partial V_x}{\partial y}$ is consistent with the reasoning for the sign of $\frac{\partial V_y}{\partial x}$. Student responses for Field 1 (Figure 3b) stated that there is no change in the y -direction which could be interpreted as no change in the y -component (correct) or as no change with changes in the y -coordinate (incorrect). This response might thus be explaining $\frac{\partial V_y}{\partial x}$ or $\frac{\partial V_y}{\partial y}$ rather than $\frac{\partial V_x}{\partial y}$. We suspect that determining $\frac{\partial V_x}{\partial x}$ is more similar to finding traditional scalar derivatives of a function than finding $\frac{\partial V_x}{\partial y}$, resulting in more students correctly determining $\frac{\partial V_x}{\partial x}$ for Field 1.

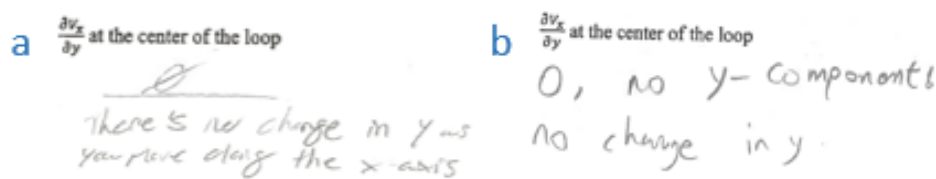

Figure 3: Student responses showing incorrect notation mapping to derivatives for Field 1

For Field 2, 78% students answered $\frac{\partial V_x}{\partial y}$ correctly. But there were still students who incorrectly mapped notations to derivatives. Figures 4a and 4b show responses from a student for $\frac{\partial V_y}{\partial x}$ and $\frac{\partial V_x}{\partial y}$, respectively, and suggest that this student mapped notations incorrectly for $\frac{\partial V_x}{\partial y}$ and $\frac{\partial V_y}{\partial x}$. In Figure 4a, the response explains how V_x changes along the y -axis even though the question asked about $\frac{\partial V_y}{\partial x}$. Similarly, the response in Figure 4b explains how V_y changes along the x -axis instead of $\frac{\partial V_x}{\partial y}$. Our results show that dealing with derivatives of vector quantities has added additional complications, and more work needs to be done to understand student reasoning about partial derivatives of vector fields.

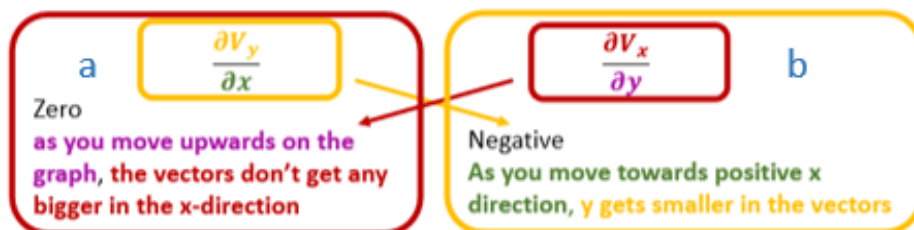

Figure 4: Student responses showing incorrect notation mapping to derivatives for Field 2 (a, b)
Colored text in response corresponds to similarly colored elements of derivative

Conclusions and reflections

We conclude from our work that determining the signs of the constituent derivatives of divergence and curl was a challenging task for students. Furthermore, some challenges were dependent on the properties of the specific vector fields, e.g., when the vector field had a single component or when a vector field component was negative. Student responses suggested confusion between the change in components and the change in a coordinate, perhaps indicating that students do not interpret the partial derivative notation correctly. We suggest that instructors may wish to integrate tasks including vector field diagrams into their class and develop instructional materials, since vector field diagrams can provide an avenue for students to link more procedural understanding with graphical representations and explicitly attend to the difference between the change in a component of a vector field component and the change in a coordinate.

We have also examined student reasoning on the divergence and curl of these diagrams; results will be included in future work. We plan to complement and extend our investigation via clinical interviews. Also, different tasks will be included to further probe the extent to which reasoning depends on characteristics of the vector field.

Acknowledgment

This work is supported in part by the National Science Foundation under Grant Nos. PHY-1912087 and PHY-1912660.

References

- Baily, C., & Astolfi, C. (2014). *Student Reasoning about the Divergence of a Vector Field. 1*, 31–34. <https://doi.org/10.1119/perc.2014.pr.004>
- Bollen, L., Van Kampen, P., & De Cock, M. (2015). Students' difficulties with vector calculus in electrodynamics. *Physical Review Special Topics - Physics Education Research*, *11*(2), 1–14. <https://doi.org/10.1103/PhysRevSTPER.11.020129>
- Gire, E., & Price, E. (2011). Graphical representations of vector functions in upper-division E&M. *AIP Conference Proceedings*, *1413*, 27–30. <https://doi.org/10.1063/1.3679985>
- Roundy, D., Manogue, C. A., Wagner, J. F., Weber, E., & Dray, T. (2015). An extended theoretical framework for the concept of derivative. *18th Annual Conference on Research in Undergraduate Mathematics Education Proceedings*, *1*, 919–924.
- Singh, C., & Maries, A. (2013). Core graduate courses: A missed learning opportunity? *AIP Conference Proceedings*, *1513*, 382–385. <https://doi.org/10.1063/1.4789732>
- Topdemir, Z., Loverude, M. E., & Thompson, J. R. (2023). Physics Student Understanding of Divergence and Curl and Their Constituent Partial Derivatives. *Proceedings of the 25th Annual Conference on Research in Undergraduate Mathematics Education. Omaha, NE*.
- Wangberg, A., & Gire, E. (2019). Raising Calculus to the Surface: Extending derivatives and concepts with multiple representations. *Calculus in Upper Secondary and Beginning University Mathematics*, 122.
- Zandieh, M. (2000). A theoretical framework for analyzing student understanding of the concept of derivative. *CBMS Issues in Mathematics Education*, *8*, 103–127.

The use of modeling in the learning of differential equations in an economics course

María Trigueros¹ and Rafael Martínez-Planell²

¹Benemérita Universidad Autónoma de Puebla, México; mtriguerosg@gmail.com

²Universidad de Puerto Rico en Mayagüez, Puerto Rico; rmplanell@gmail.com

Economics majors at the university are usually introduced to differential equations from the mathematics point of view, complemented with examples of applications to their discipline. The study of differential equations has become very important in a wide variety of disciplines. Given the importance of dynamic problems in Economics, they have also become an object of study for Economics students at many universities. However, most courses focus on the mathematics of this discipline, and applications are used to illustrate the theory and different solution methods that students may find in their economics courses and to use their calculus knowledge together with what they know about economics to approach them. Although modeling has been used successfully in differential equation courses (e.g., Chaachua & Saglam, 2006), it has been seldom used in mathematics courses for economics students (Trigueros, 2014).

In this paper, we present a modeling experience in the context of a differential equations class for students in an economics course. Our research questions are: how do students approach an open modeling situation where they can use their mathematical and economics knowledge? Which important and powerful conceptual ideas do students develop throughout the experience?

Theoretical framework

We use APOS (Action, Process, Object, Schema) theory as the theoretical framework for this study (Arnon et al., 2014). One of the fundamental objectives of APOS is to stimulate learning by developing pedagogical activities based on a theoretical model used in the classroom following a didactic cycle and validated by research results. The main constructs of the theory are the structures needed in the construction of mathematical concepts: Actions, Processes, Objects, and Schemas, and the mechanisms involved in the construction of those structures. In this paper, we use mainly and only describe the Schema structure. A Schema for a mathematical concept is a collection of Actions, Processes, Objects, and other Schemas. They are dynamic structures that are continuously changing. The development of the Schema is described in APOS theory by means of Piaget's triad stages (Arnon, 2014). The Intra-stage is manifested through the existence of isolated or weakly related structures. Relations at this level can be considered correspondence relations. In the Inter-stage, transformation relations are developed among the structures composing the Schema; structures are grouped and can even be identified by the same name. The Trans- stage is characterized by the construction of synthesis among the structures in the Schema, or a unifying principle; there is awareness of the relations, and conservation relations are constructed. When a Schema is coherent, the students can decide if it can be used in a specific situation.

To use APOS theory, it is necessary to develop a genetic decomposition (GD). This model is used to predict how concepts are constructed by describing the structures and mechanisms that

researchers consider are needed to construct the concepts of interest. In the case of a Schema, it describes the structures included, together with the type of relations and unifying principle needed in its development. GDs must be tested by research studies. A GD need not be unique.

More recently, the possibility of constructing mathematical objects by doing actions on mental objects not directly related to mathematics has been studied (e.g., Trigueros, 2014). This occurs when modeling is used to introduce mathematical concepts. The modeling process can be described in terms of APOS: When students need to model, they coordinate mathematical and non-mathematical Schemas to solve the problem. Students take the structures needed to select variables from these Schemas and formulate their initial hypotheses, possible simplification, and their mathematical expression. Starting from these hypotheses, it is possible to perform actions on the mathematical and extra-mathematical variables to establish relations between them. These actions are interiorized into processes that allow to manipulate and transform the original relations. Processes from extra-mathematical Schemas are coordinated with processes from mathematical Schemas. The result of that coordination is a process describing a mathematical model that can be encapsulated into an object. Actions and processes are then performed on the model to analyze it, determine its properties, and ask new questions that may lead to its modification. This cycle can be repeated until an appropriate model is found (Trigueros, 2014). In this study, we used an existing genetic decomposition for differential equations (Trigueros, 2014) and the economics Schema components of diffusion speed and pattern as Processes.

Methodology

The research was conducted within a Differential Equations course for twenty-seven students in an Economics program at a university in Mexico. Students were asked to develop a model to predict how an innovative product would spread in a community. Students worked in teams of three students in the classroom and at home for a month. Students could select the innovation to study and had to turn in a report based on their data and a clear explanation of their findings, that is, the model development; data collection; use of data to test the models' predictions, and a conclusion about the quality of those predictions. If they concluded their model was not good enough, they had to suggest how to modify their initial proposal. The researchers analyzed all the information gathered during the modeling cycles and from the observation of groups and whole class discussions, and discussed with two teachers for triangulation. Students had taken a sequence of one-variable and multivariable Calculus courses. When the project started, students had already developed a price model as an introduction to differential equations. The teacher used activities for students based on the differential equations GD to introduce and formalize new concepts and help them do the needed constructions. The model could but need not include differential equations. In fact, initial models included algebraic or graphical representations, but variation considerations started to appear through group discussions and work on activities. The problem required several modeling cycles. We designed observation guides for the teacher and one observer to follow students' work and document students' important ideas in class. Students had to hand in their work at the end of each cycle. The researcher and a teacher analyzed these separately and negotiated the results. All the data were used to study the evolution of students' Schemas and to underline powerful ideas developed by groups of students. We show the results according to the broad cycles.

Results

The first cycle started with teams describing how they considered innovations to spread in society. Six teams used the analytical expression of an exponential function or drew its graph. In one of them, students discussed the need to use another function that would approach a limit and drew a graph similar to a logistic function. In the others, students discussed using models for the change of the function instead of the function itself. These last teams suggested some hypotheses to develop their model. One of them proposed that the change in the number of people “buying” the innovation depended on time and the number of people who could buy it; they used that the change in buyers could be considered proportional to the buyers’ population. Another considered that different segments of the total population would act differently towards an innovation and that the change of users of the innovation had to consider the sum of those populations that would grow in different ways according basically to their initial resources. The third group assumed that a fixed number of people would be interested in the innovation and proposed that the adopters’ change would be proportional to the number of adopters of the innovation minus the proportion of people who had been interested but had not adopted it. All students showed the construction of correspondence relation between function and time or derivative and time and innovation spread considerations. Some students suggested the need to introduce the initial population getting the innovation explicitly in the model but were finally convinced by other students that it was not needed. After the whole group discussion, all teams developed a model including the change of the adopters of the innovation with time but differed on the proposed model; one team used $N' = kNt$, three teams used the model $N' = kN$, and five teams used the model $N' = kN - j(T-N)$ with T being the total population interested in the innovation.

Students used their function, derivative, and economics knowledge Schemas from the start. They used their hypothesis to write a model. They coordinated their economics and derivative Schemas into a new differential equation Schema (DES) which they had not studied before.

During the second cycle, students analyzed their models using prior knowledge to determine how the innovation would spread. Students struggled, but through collaboration they were able, for example, to relate the derivative in the first and second models with the growth of the function using Calculus, showing to have constructed correspondence relations between derivative and function, and by drawing a curve describing the growth of the adopters in time. A team decided to use the second derivative and decided the curve was concave up. The same happened in two other teams where students determined that the function would grow when $N < T$ and decrease if $N > T$, “which does not occur in this problem.” One team used the second derivative to analyze concavity and found that the function had an inflection point. These students showed the construction of a transformation relation since they conceived the derivative in such a way that they could explain how the first and second derivatives transform the function. One student of this group suggested graphing N' versus N “since the time does not appear explicitly in the equation.” Doing this, they discovered a new way to analyze the behavior of the solution without solving the equation, which showed the construction of a conservation transformation relation; “When this line is zero that means there is an equilibrium solution and we see here that the innovation curve will tend to it.” During whole class discussion students described their findings and the teacher formalized students’

findings. This cycle shows DES-Schema development. For some students, Schemas develop as Inter-DES resulting from the transformation relations, and for one team, as Trans-DES given the construction of conservation relations between Schema components. The students who constructed a Trans-DES Schema found in the phase space a new representation and important new tool to analyze the solution function.

The third cycle began when the teacher asked students to use their calculus knowledge to solve the equation in their model. Students who used the logistic model constructed new transformation relations since they had to write their equation in a way that made it possible to determine the appropriate integration method to find the solution. While students using the exponential model constructed new correspondence relations. The whole class discussion was devoted to the explanation of integration methods. Finally, as homework, students looked for data. Different teams selected different innovations and compared the data with the prediction of their model after using the minimum square method to find the value of the model's parameters. They also showed their results through graphical representation and gave their interpretation and critical comment about their model's predictions.

Discussion

This experience exemplifies the way modeling can be used to get economics majors interested in the use of mathematics and foster an understanding of what is a differential equation and its usefulness in other disciplines. Students were so involved in their work that they developed the phase plane on their own. Students were able to use their previous calculus knowledge to interpret the behavior of the solution without solving the equation and related the phase space representation with the graph of the solution before solving it: They considered the solution as a function.

The experience contributed to the development of students' DES Schema. Even though the Schema developed is a simple DES Schema, the possibility to construct different relations between its components opens the door to its further development through course activities. The results of this study show that when teachers give students the opportunity to work by themselves on an interesting problem, students can use their previous mathematics and economics knowledge and their previous everyday experience in new and creative ways, verify that their thinking makes sense in terms of the problem situation, and develop a way to solve the problem.

References

- Arnon, I., Cottrill, J., Dubinsky, E., Oktaç, A., Roa Fuentes, S., Trigueros, M., & Weller, K. (2014). *APOS Theory: A framework for research and curriculum development in mathematics education*. Nueva York: Springer.
- Chaachoua, H., & Saglam, A. (2006). Modelling by differential equations. *Teaching mathematics and its applications*, 25, 15–22. Oxford University Press.
- Trigueros, M. (2014). Vínculo entre la modelación y el uso de representaciones en la comprensión de los conceptos de ecuación diferencial de primer orden y de solución. *Educación Matemática*, 25 años (número especial), 207–226.

Making the structural role of mathematics in physics explicit for students: design of a tutorial in the context of the heat equation

Sofie Van den Eynde¹, Martin Goedhart¹, Johan Deprez² and Mieke De Cock²

¹University of Groningen, the Netherlands; s.van.den.eynde@rug.nl, m.j.goedhart@rug.nl

²KU Leuven, Belgium; johan.deprez@kuleuven.be, mieke.decock@kuleuven.be

Introducing the problem

Physical concepts are expressed in terms of mathematical structures. Using mathematics in physics requires more than the straightforward application of rules and mathematical procedures. Mathematics does not only have a technical role, but also a structural one (Uhdén et al., 2012). The idea of teaching mathematics as a basis for physics is outdated. In this study, we see mathematics and physics as two disciplines that are intertwined and have the potential to enhance each other. When mathematics and physics are blended, new ideas and inferences emerge, resulting in an enhanced understanding of both (Bing & Redish, 2007). In the learning process, the physics reasoning informs the mathematical thinking which in turn informs the physics (Brahmia, 2017).

The (1D) heat equation is one of the ‘standard’ partial differential equations taught in the undergraduate program of physics and mathematics majors. This partial differential equation models the evolution of the temperature T at position x and time t in a one-dimensional system of length L : $\frac{\partial T}{\partial t}(x, t) = \alpha \frac{\partial^2 T}{\partial x^2}(x, t)$ for $0 < x < L$ and $0 < t < \infty$. In this equation, α is the (constant) thermal diffusivity (Farlow, 1993). Heat flow is an important physical concept in the context of the heat equation. Heat flow is described by Fourier’s law $\frac{\partial Q}{\partial t}(x, t) = -k A_x \frac{\partial T}{\partial x}(x, t)$. It states that the heat Q that flows through a unit area per unit of time is proportional to the negative temperature gradient.

In this study, we designed a tutorial that focuses on the learning goal “After completion of the tutorial, the students can explain how $\frac{\partial T}{\partial x}(x, t)$ gives information about the heat flow through a certain position at a certain moment in time. The partial derivative with respect to position is more challenging to interpret physically for students than the derivative with respect to time. Therefore, in this study, we developed and evaluated a learning path to support students in making the connections between the mathematical and physical concepts involved.

Theoretical framework and design of the tutorial

The three design principles that guide our design are: (1) giving explicit attention to both the mathematical and the physical aspects, (2) stimulating graphical reasoning, and (3) guiding students to (de-)encapsulate the partial derivative in order to blend mathematical and physical meaning. The third design principle is the most important for this paper. Figure 1 visualizes the idea of blended encapsulation, which is based on a combination of several theoretical frameworks and constructs: conceptual blending (Fauconnier & Turner, 1998), Zandieh’s framework for the concept of derivative (Zandieh, 2000), and encapsulation (Dubinsky, 1991).

Zandieh developed a theoretical framework to clarify, describe and organize the different aspects of the understanding of the concept of derivative. Her framework is built on two main components. *multiple representations* form the columns, and the rows consist of different *layers of process-object pairs*. The concept of derivative can be expressed using different representations (see Figure 2 for examples in the different columns). In the original framework, Zandieh included a column ‘other’ to account for all other contexts or representations in which there is a functional relationship for which one may discuss the concept of derivative. In the context of our tutorial, we extend it with columns focusing on physics to represent the blending that has to take place in order to formulate the relation between $\partial T/\partial x$ and heat flow. The derivative of a function $f(x)$ is a function whose value at any point is defined as the limit of a ratio of a difference. These three underlined aspects of the concept of derivative form the layers of the framework in Figures 1 and 2. Each layer can be seen as both a dynamic process and a static object. Processes are operations on previously established objects. Each process is reified into an object to be acted on by other processes. The process-object pairs form a chain where one can move within a layer from a process to an object, and where this resulting object is acted on in turn by the process at the next layer. The mechanism behind this concept construction is described by *encapsulation* (Dubinsky, 1991). Projecting this onto our context of the partial derivative $\partial T/\partial x$, encapsulation happens when students learn how the concept of (partial) derivative is structured by its underlying processes and objects at the different layers. Once the (partial) derivative is encapsulated, the students can apply actions on this partial derivative without constantly acknowledging all the underlying concepts. However, they should be able to de-encapsulate the concept and access these separate underlying processes and objects (see vertical arrows in Figure 1).

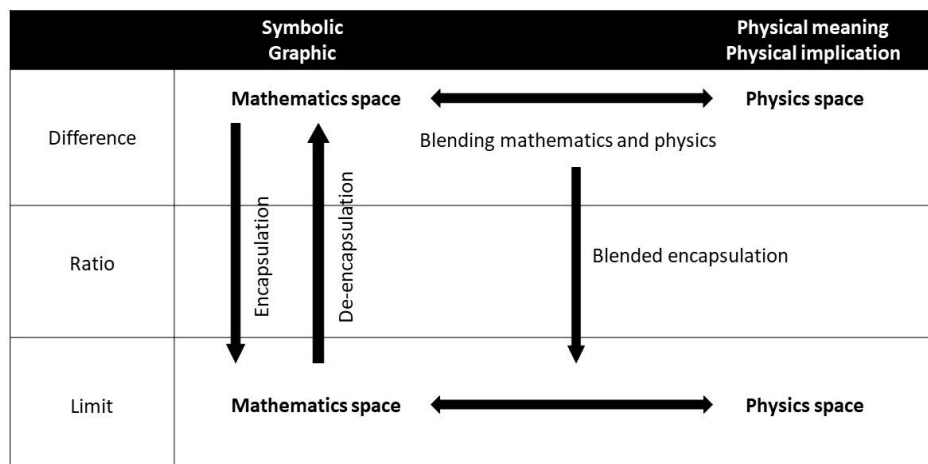

Figure 1 Visualization of the third design principle: blended encapsulation

We use this theoretical foundation to develop an instructional approach that stimulates students to formulate the relation between the partial derivative $\partial T/\partial x$ and heat flow. We hypothesize that guiding the students to form this blend at the difference layer and then encapsulate that blend to the limit layer might be a fruitful way to build the relation between $\partial T/\partial x$ and heat flow. Therefore, in the developed tutorial, we guide students in making the blend at the difference layer and then foster blended encapsulation, i.e. encapsulating the concept of partial derivative while maintaining the

connections between the mathematical and the physical concepts. Figure 2 shows the details of the concept construction per layer and representation.¹

Process-object layer	Representations			Physical implication
	Symbolic	Graphic	Physical meaning	
Difference	$T(x_2, t_0) - T(x_1, t_0)$		Difference between temperatures at positions x_1 and x_2 at time $t = t_0$	A temperature difference causes heat to flow from high to low temperatures 1.j
Ratio	$\frac{T(x_1 + h, t_0) - T(x_1, t_0)}{h}$		Temperature gradient between x_1 and x_2 at time $t = t_0$	The temperature gradient relates to the direction and strength of the heat flow between x_1 and x_2 at time $t = t_0$ 1.k
Limit	$\frac{\partial T}{\partial x}(x_1, t_0)$ $= \lim_{h \rightarrow 0} \frac{T(x_1 + h, t_0) - T(x_1, t_0)}{h}$		Temperature gradient in x_1 at time $t = t_0$	Temperature gradient in x_1 at time $t = t_0$ is proportional to the heat flow through x_1 1.l, 1.m

Figure 2 Overview of the blended partial derivative framework for the relation between $\frac{\partial T}{\partial x}$ and heat flow. The table shows how the developed tutorial tasks (1.j, 1.k, 1.l and 1.m) relate to the framework

Exploratory evaluation of the blended encapsulation approach

We tested the tutorial in a teaching-learning interview setting. This allows us to see in detail what reasoning is induced by the tasks in this tutorial. We conducted interviews with three groups of three second year undergraduate students majoring in mathematics and/or physics at KU Leuven who completed a course on differential equations in the previous semester. We treated each group as a case study and provided a “thick description” of the reasoning process complemented with excerpts from the transcript in order to present how each group responded to the developed tasks. The framework (Figure 2) is used to interpret each group’s reasoning steps and situate their answers in terms of the different layers and representations. Hence, the framework plays a double role in this study: in design and analysis.

Overall, we see that all groups eventually formulate the relation between $\partial T/\partial x$ and heat flow at the limit layer in response to task 1.m (see Figure 2). However, we observe that the reasoning leading up to that point does not always follow the blended encapsulation trajectory as intended. For Group 1, we conclude that the task design prompts the intended reasoning. The reasoning of group 2, however, shows that following the intended path based on blended encapsulation in tasks 1.j-1.l does not guarantee a fluent conclusion in response to task 1.m. Group 2 forms the basis as anticipated in the design, but when asked to summarize their insights and once more relate all

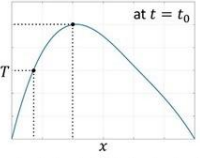
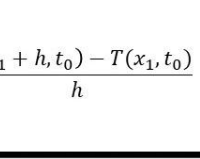
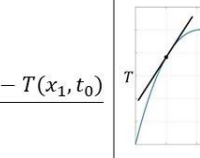
¹ The developed materials and further explanation can be found in ‘Chapter 5’ at the following link: <https://research.rug.nl/en/publications/blending-of-mathematics-and-physics-undergraduate-students-reason>.

concepts, they do not use that formed basis to reach the desired conclusion. They did reach this conclusion, but only after re-doing the whole reasoning. Group 3 also arrived at the correct relation between $\partial T/\partial x$ and heat flow, but without following the intended learning path. The tasks failed to lead them towards $\partial T/\partial x$, but instead they reasoned in terms of $\partial T/\partial t$. Moreover, they did not answer parts of the tasks that were designed to foster the structure of the blended encapsulation sequence. Ignoring these prompts might partially explain why the blended encapsulation sequence did not have the intended effect for them. The reasoning of group 3 shows that it is also possible to formulate the intended conclusion in 1.m without following the blended encapsulation trajectory. However, the reasoning of group 3 was very brief and we cannot judge if they have understood the relation between the different concepts thoroughly. We do not see proof that their conclusion is based on understanding of the underlying layers.

Generally, we conclude that the blended encapsulation approach has the potential to help students in recognizing the way temperature differences lead to heat flow and how these temperature differences between positions can be described using the concept of a partial derivative of temperature with respect to position. However, there are still some weaknesses in the current design that need to be optimized in order for the approach to reach its full potential.

The blended partial derivative framework (Figure 2) can be adapted for any physical concept that is modelled by a (partial) derivative. This way, blended encapsulation can guide the instruction of these concepts, e.g. the more straightforward concepts of velocity and acceleration, but also more advanced concepts from electrodynamics or thermodynamics. By extension, the blended encapsulation approach could also be interesting for other mathematical concepts that have a similar layered structure, e.g. a definite integral. This opens the possibility of incorporating the approach for many more physical concepts.

References

- Bing, T. J., & Redish, E. F. (2007). The cognitive blending of mathematics and physics knowledge. *AIP Conference Proceedings*, 883, 26–29.
- Brahmia, S. (2017). Negative quantities in mechanics: a fine-grained math and physics conceptual blend? In L. Ding, A. Traxler, & Y. Cao (Eds.), *Physics education research conference proceedings* (pp. 64–67).
- Dubinsky, E. (1991). Reflective abstraction in advanced mathematical thinking. In D. Tall (Ed.), *Advanced mathematical thinking* (Vol. 11, pp. 95–123). Springer.
- Farlow, S. J. (1993). *Partial differential equations for scientists and engineers*. Courier Corporation.
- Fauconnier, G., & Turner, M. (1998). Conceptual integration networks. *Cognitive science*, 22(2), 133–187.
- Uhden, O., Karam, R., Pietrocola, M., & Pospiech, G. (2012). Modelling mathematical reasoning in physics education. *Science & Education*, 21(4), 485–506.
- Zandieh, M. (2000). A theoretical framework for analyzing student understanding of the concept of derivative. *CBMS Issues in Mathematics Education*, 8, 103–127.

Instances of confounding when differentiating vector fields

Mesa Walker¹ and Tevian Dray¹

¹Oregon State University, Corvallis, OR, USA; teviaan@math.oregonstate.edu

Introduction

Vector fields are important objects in both mathematics and physics. In vector calculus courses, students are typically introduced to the idea of a vector field and learn about two different types of vector field derivatives, namely divergence and curl. These two vector derivative operators are used frequently in electromagnetism, but students are not usually asked to consider other derivatives of vector fields. There is a gap in the literature on student understanding of derivatives of a vector field other than divergence and curl.

There are two main student approaches when trying to take a more general derivative of a vector field: a component-based approach, where students attempt to differentiate each component individually, and a geometric, vector-valued approach, where students subtract two nearby vectors. Within these broad categories, students can use a variety of methods and strategies to find a derivative, including graphical approaches, numerical approaches, and utilizing what they know about divergence and curl. These techniques may not be available to a student at the same time, depending on the information the student has, and how much experience the student has had with derivatives and vector fields. Due to the unfamiliar nature of a more general vector field derivative than divergence and curl to many undergraduate physics and mathematics students, it is of interest to study the approaches students take when attempting to differentiate a vector field.

In this study, three junior-level physics students were asked to think about taking a derivative of a vector field. Each student displayed evidence of confounding the components of the vector field with either the independent variables (two students) or the basis directions (one student), thus impacting their ability to recognize that a derivative can also be a vector field. We analyze the interview data related to confounding, and discuss implications for instructors teaching calculus.

Literature review

Student understanding of derivatives and vector fields is of interest to both mathematics and physics education, and the current literature shows a wide variety of concepts, misunderstandings, and ideas that students have when thinking about vectors and derivatives separately. This review spotlights the work of a few authors who study how students think about derivatives in a vector calculus setting, and notes the similarities and patterns that show up throughout the literature explored.

There have been several studies that provide insight into students' struggles and understanding of vector fields, particularly in the context of electricity and magnetism. For example, Dray and Manogue (1999) outline the differences between how vector calculus is taught in mathematics and the way vector calculus is used in physics, and the possible impacts this "gap" has on student understanding. They explain that mathematics courses emphasize algebraic understanding and calculations, whereas physics courses typically use graphical understanding and symmetry, with

less emphasis placed on algebra. The authors suggest that this disparity may contribute to student difficulties in understanding vector calculus in physics contexts, and suggest more communication between mathematics and physics instructors as a possible solution to the problem. Similarly, Gire and Price (2012) found that students see variable and component as interchangeable when looking at algebraic representations of vector fields, and consequently creating a graph of a vector field from an algebraic function is exceptionally difficult for students. They found that students have a particularly difficult time separating variable from component when the x component depends on the y variable and vice-versa.

The Colorado Upper-Division E&M Instrument (CUE) has been used in many studies to test student understanding of electricity and magnetism. This instrument was developed by physics education researchers at the University of Colorado to measure how students think about a variety of concepts in electricity and magnetism, including vector calculus (Chasteen et al., 2012). Pepper et al. (2012) used interview data in addition to the CUE and found that students tend to focus on one part of vector fields (either direction or magnitude) when doing calculations. Whether the students focused on magnitude or direction differed depending on the problem, but the pattern persisted throughout the exam. The CUE also showed that students had difficulty understanding the physical meaning behind vector field operations, such as gradient, divergence, and curl. The students were able to calculate the gradient, divergence, and curl, but were often unable to explain what the results meant, corroborating the results of similar studies on student understanding of vector calculus.

Methods

Individual interviews had been previously conducted with four students at the end of the Static Fields Paradigms course at Oregon State University. The interviews aimed to determine how students think about partial derivatives of functions. The first phase of the interviews asked students to think about the partial derivative of a scalar-valued function, and the second phase of the interview prompted the students to think about the partial derivative of a vector field. Three of the four students completed both phases of the interview. This paper only focuses on the vector field phase of the protocol, although some students reference their work on the scalar field during the vector field phase. Students were encouraged to say their thoughts and processes out loud, and to write/draw on the provided paper throughout the interview. Each interview lasted approximately 90 minutes, with each phase lasting approximately 45 minutes.

At the time of the interview, the students would have completed the entire calculus sequence, including vector calculus 1 and 2, and the general calculus-based physics sequence. The students also likely had completed a sophomore-level course introducing ideas such as relativity, quantum physics, statistical physics, and other physical ideas from the 20th century.

The interview transcripts and videos were analyzed qualitatively, in the style of Thematic Analysis (Aronson, 1995). Thematic analysis consists of several steps, including the identification of patterns in the data and sorting the data into subthemes.

We identified confounding as a commonality among all three students interviewed. Within the confounding pattern, we identified two subthemes, namely confounding variable with component and confounding component with variable, only the first of which will be discussed here.

Results

We define *confounding* as imposing a strong relationship between two unrelated objects or concepts, resulting in a student treating the confounded objects or concepts as though an action on one imposes the same action on the other. There are two different levels of confounding, which we call “strong” confounding and “weak” confounding. A student who fails to recognize that the two objects confounded are distinct would be demonstrating strong confounding, whereas a student who recognizes that the objects are different but nonetheless treats them as indistinct or strongly linked would be demonstrating weak confounding. Alex and Bailey each demonstrated weak confounding of variables and components. Due to space limitations we paraphrase only Bailey’s comments here.

The interviewer asked Bailey if there was a way to figure out how the y component changes with respect to x , which appeared to cause Bailey to doubt his earlier claim that the y component changes with respect to x . These comments show that Bailey understood the distinction between variable and component, and that y was used to represent two things. However, when trying to take a partial derivative with respect to x , Bailey did not know whether to hold the y component or the y variable constant. His previous discussion of divergence may have led him to the conclusion that only the x component should be differentiated when taking a partial derivative with respect to x , but he struggled when the interviewer asked if the y component was changing. This is an example of Bailey’s confounding, because although Bailey had previously expressed understanding that both components depend on both variables, he rejected the idea that differentiating with respect to x would give information about the y component. The interviewer’s prompt about finding how the y component changes with respect to x appeared to cause Bailey to doubt his previous claim, so he began to consider what it would mean to hold y constant. Bailey’s unconfounding process started when he realized that his previous difficulty was due to y representing both the y component and y variable. Bailey did not know what he was supposed to be holding constant, and this uncertainty combined with the idea of divergence being recently on his mind likely led him to hold both the y component and the y variable constant, and only differentiate the x component with respect to x .

Discussion

Bailey started out by discussing divergence and gradient, both of which correlate variable with component, and clearly had difficulty imagining uncorrelated “cross terms”, such as those that would show up in curl. Although Bailey understood the difference between variable and component, he was unsure which to hold constant – a clear instance of weak confounding. During the course of the interview, Bailey began to identify the source of his confusion, thus beginning to unconfound variable and component.

Although Alex demonstrated early awareness of the dependence on each vector component on both independent variables, he nonetheless acted as though there was a correlation, thus also weakly confounding variable and component. However, he was then able to use a graphical approach to unconfound these two objects.

When analyzing physics students’ use of mathematics terminology, it is important to take into account the different ways that these two disciplines use and refer to derivatives. For instance, physicists predominantly use Leibniz notation for derivatives, assigning physical meaning to the

infinitesimals in the numerator and denominator as “small changes”, whereas mathematicians predominantly use primes, implicitly emphasizing that differentiation is an operator that acts on functions. Furthermore, physicists use subscripts to denote components, whereas mathematicians use them to denote differentiation. These notational issues reflect different conceptual emphases, which can be especially confusing for physics students when first using physics notation to express gradient and divergence, precisely the context in which these interviews were conducted.

Because the number of students interviewed is small, the conclusions this study draws and the implications thereof may not be indicative of the entire student body. That said, given the strong evidence in this study that students confound variable with component, greater emphasis should be placed on distinguishing between them. Explicit examples could be presented during instruction demonstrating that these two objects are not interchangeable, despite having similar labels. An activity similar to the interview protocol, where students are given a vector field and asked to take its partial derivative, would force students to think about the dependence of the components on the independent variables outside of the context of divergence and curl, thus solidifying their understanding of the underlying concepts. The extent to which notation can and should be chosen so as to reduce such student confusion is worthy of further study.

Acknowledgments

This work is based on a paper submitted by the first author (MW) in partial fulfillment of the degree requirements for her M.S. in Mathematics at Oregon State University (Walker, 2019). We thank Paul Emigh for conducting these interviews and allowing their use in this study, and Corinne Manogue for frequent discussions. This project was supported in part by NSF grant DUE-1323800.

References

- Aronson, J. (1995). A Pragmatic View of Thematic Analysis. *The Qualitative Report*, 2(1), 1-3. <https://doi.org/10.46743/2160-3715/1995.2069>
- Chasteen, S. V., Pepper, R. E., Caballero, M. D., Pollock, S. J., & Perkins, K. K. (2012). Colorado Upper-Division Electrostatics diagnostic: A conceptual assessment for the junior level. *Phys. Rev. ST Phys. Educ. Res.*, 8, 020108. <https://doi.org/10.1103/PhysRevSTPER.8.020108>
- Dray, T., & Manogue, C. A. (1999). The vector calculus gap. *PRIMUS*, 9(1), 21-28. <https://doi.org/10.1080/10511979908965913>
- Gire, E., & Price, E. (2012). Graphical representations of vector functions in upper-division E&M. *AIP Conference Proceedings*, 1413(1), 27-30. <https://doi.org/10.1063/1.3679985>
- Pepper, R., Chasteen, S. V., Pollock, S. J., & Perkins, K. K. (2012). Observations on student difficulties with mathematics in upper-division electricity and magnetism. *Phys. Rev. ST Phys. Educ. Res.*, 8, 010111. <https://doi.org/10.1103/PhysRevSTPER.8.010111>
- Walker, M. (2019). Student Thoughts on Derivatives of Vector Fields (Unpublished master's thesis). Oregon State University, https://ir.library.oregonstate.edu/concern/graduate_projects/xg94hw302